

THIS FILE IS MADE AVAILABLE THROUGH THE DECLASSIFICATION EFFORTS AND RESEARCH OF:

# THE BLACK VAULT

THE BLACK VAULT IS THE LARGEST ONLINE FREEDOM OF INFORMATION ACT / GOVERNMENT RECORD CLEARING HOUSE IN THE WORLD. THE RESEARCH EFFORTS HERE ARE RESPONSIBLE FOR THE DECLASSIFICATION OF THOUSANDS OF DOCUMENTS THROUGHOUT THE U.S. GOVERNMENT, AND ALL CAN BE DOWNLOADED BY VISITING:

[HTTP://WWW.BLACKVAULT.COM](http://www.blackvault.com)

YOU ARE ENCOURAGED TO FORWARD THIS DOCUMENT TO YOUR FRIENDS, BUT PLEASE KEEP THIS IDENTIFYING IMAGE AT THE TOP OF THE .PDF SO OTHERS CAN DOWNLOAD MORE!



[REDACTED] [REDACTED]

**HEADQUARTERS**  
**MILITARY EQUIPMENT DELIVERY TEAM, CAMBODIA**  
**APO San Francisco 96408**

30 April 1975

**MEDTC-SACSA**

**SUBJECT: End of Tour Report**

**Commander in Chief, Pacific**  
**FPO San Francisco 96610**

1. The attached End of Tour Report is submitted in accordance with CINCPACINST 3000.7A. The report covers the period February 1974 to April 1975.
2. The report analyzes the failure of the US to achieve its objectives in Cambodia from the MEDTC point of view. It follows closely the End of Tour Report submitted by MG John R.D. Cleland on 20 February 1974.
3. The report is organized into two parts. Part One is an overview of some interrelated factors which led to the defeat of the FANK. Part Two is a series of annexes and appendices analyzing specific MEDTC activities, programs and problem areas. The report's principal conclusions are contained in Part One. The annexes in Part Two are basically organized along service lines and are designed to provide succinct reference sources on the topics covered.
4. Upon approval and appropriate comment, it is recommended that this report and its predecessors (MG Cleland; BG Mataxis, 12 February 1972) be downgraded to the lowest possible classification and released to appropriate service schools and research organizations to further informed study of this pivotal chapter in the history of the US security assistance effort.
5. It is hoped that this report will be of assistance to those who may at some future time be charged with determining policy and organization, military doctrine, training and tactics for the security assistance effort should the United States again be charged with providing support under special circumstances similar to those obtaining in Cambodia.

1 Attach  
as

*William W. Palmer*  
**WILLIAM W. PALMER**  
Brigadier General, USA  
Chief

**DOWNGRADED TO UNCLASSIFIED WHEN  
REMOVED FROM CLASSIFIED INCLOSURES**

[REDACTED] [REDACTED]

END OF TOUR REPORT  
MEDTC, BG WILLIAM W. PALMER  
FEBRUARY 1974 - APRIL 1975

PART ONE

- I. Introduction
- II. The Khmer Communist Enemy
  - A. Objectives
  - B. KC Performance and Problems
  - C. Conclusions
- III. The GKR/FANK
  - A. National Strategy
  - B. Performance and Problems
    - (1) Leadership, Command and Staff
    - (2) Discipline and Esprit
    - (3) Implementation of Plans/Policy
    - (4) Interservice Coordination
    - (5) Personnel and Manpower Management; Recruiting
    - (6) Military Pay
    - (7) Support
    - (8) Training
  - C. Conclusions
- IV. US Policy, Objectives, Programs
  - A. Objectives
  - B. Performance, Problems, Limitations
    - (1) Congressional Restrictions
    - (2) Reliance on Firepower
    - (3) MEDTC Reorganization
    - (4) MAP/CRA/Funding
  - C. Conclusions
- V. Summary of Conclusions

PART TWO

**Annexes**

**A. MEDIC Organization and Functions**

1. Organization Chart
2. JLO - Samae San
3. JLO - Bangkok

**B. Army**

1. Infantry
2. Artillery
3. Armor
4. Engineer Operations and Logistics
5. Special Forces
6. Psychological Warfare
7. Signal Operations
8. Ordnance Maintenance
9. Supply Operations
10. Security Assistance Planning and Programming
11. Force Structure
12. Military Rice Distribution
13. In-Country Training
14. CONUS Training
15. Third Country Training
16. Finance
17. Personnel
18. Medical

**C. Navy**

1. General
2. Operations

3. Planning/Programming
  4. Craft Acquisition
  5. Materiel, Maintenance and Supply
  6. Training
- D. Air Force
1. Air Force Division
  2. MAP for the Khmer Air Force
  3. Khmer Air Force
    - a. Organization and Personnel
    - b. Logistics
    - c. Training
    - d. Operations
    - e. Final Days of KAF
  4. Conclusions
- E. Ammunition and Services
1. Ammunition Management--Programming and Supply
  2. Ammunition Management--Inspection and Analysis
  3. Aerial Resupply
  4. POL
  5. Transportation
  6. Third Country Nationals (TCN)
- F. Programming Management
- G. Emergency Evacuation Plan (NEMVAC)
- H. Glossary of Terms

[REDACTED]

[REDACTED]

PART ONE

I. INTRODUCTION

The United States' Security Assistance Objective for Cambodia was to assist in the development of the Armed Forces of the Government of the Khmer Republic (GKR) so that they would be capable of defending the GKR from insurgency and of providing their own logistics, training and maintenance support. To help achieve that objective, the Military Equipment Delivery Team, Cambodia (MEDTC) was charged with administering and directing the Military Assistance program for the Khmer Republic (MAP-CB). On 12 April 1975, the final elements of MEDTC, along with the remaining members of the US Mission, were evacuated from Phnom Penh. On 17 April, Phnom Penh fell to the Khmer Communist insurgent forces (KC) and the GKR collapsed, terminating MAP-CB and the MEDTC mission.

The purpose of this report is to describe the myriad of activities performed in furtherance of the MEDTC mission. The relative success of those efforts is then weighed together with three interrelated factors—the KC, the GKR with its Armed Forces (FANK) and the US assistance effort—in an attempt to account for the defeat of the GKR's armed forces, the fall of the Republic and the failure of the US Security Assistance effort. Most of the key points made in MG J.R.D. Cleland's End of Tour Report, dated 20 February 1974, remain valid, particularly its conclusions and recommendations. Expansion and amplification of many of those points are central to a final accounting of the MAP-CB effort—it is particularly important to note that, despite untiring efforts on the part of every member of the Military Equipment Delivery Team and significant improvements in many of the identified areas, major conclusions concerning GKR/FANK leadership inadequacies, and unnecessary MAP constraints remained particularly valid while the KC continued to demonstrate enhanced viability through improved organization and increased logistical support. The inadequacy, uncertainty and untimeliness of FY 1975 MAP funding in the environment created by these factors caused the failure of the US Security Assistance effort in the Khmer Republic.

II. THE KHMER COMMUNIST ENEMY

A. OBJECTIVES

The primary objective of the KC remained the capture of Phnom Penh, the political-administrative capital of Cambodia and with it the destruction of Lon Nol's GKR. KC forces continually maintained pressure on GKR forces protecting the city and periodically mounted major assaults against it.

The second major attack on Phnom Penh in January, 1974, dwarfed the first offensive against the capital in August, 1973; in that more artillery, rockets and ground troops were utilized in multiple, although relatively uncoordinated, assaults. Subsequent to major offensives against

[REDACTED]

[REDACTED]

[REDACTED]

[REDACTED]

the capital, the enemy mounted selective attacks on major provincial capitals in order to maintain the initiative, tie down potential reserves, and keep psychological and military pressure on the GCR. Simultaneously and progressively, the KC either permanently interdicted or intermittently cut all GCR land lines of communication, particularly the roads into Phnom Penh. By early 1974, Phnom Penh's only reliable source of adequate resupply was the lower Mekong River LOC.

During the 1974 wet season, FANK pursued a major operation in the Bassac area southeast of Phnom Penh. FANK was also forced to respond continually to KC provincial initiatives at a level of combat intensity which did not as in previous wet seasons abate appreciably. As a result, FANK did not retrain and refit as in previous wet seasons and was not prepared for the major KC assault which was launched on 1 January with two objectives: complete interdiction of the Mekong LOC and seizure of Phnom Penh.

#### B. KC PERFORMANCE AND PROBLEMS

Although almost totally dependent upon external sources, primarily the DRV and PRC, for logistical support, the KC effectively demonstrated their capability as an independent fighting force, directed and controlled internally by the Khmer Communist Party. At the termination of hostilities the KC were credited with 230 battalions, including 35-40 regiments and 12-13 division/brigade equivalents for a total of some 55,000-65,000 combatants. VC/NVA strength in the Khmer Republic had decreased from an estimated 36,000 in March 1973 to 26,200 in December, 1974. Of this total, only 1,200 were combat troops with the remainder assigned to administrative, logistical and service organizations.

Subsequent to the withdrawal of VC/NVA main force units in 1972, KC forces launched three major offensives against Phnom Penh. In this effort, they fielded some 75 battalions during the 1973-74 dry season and from 90 to 100 battalions in their recent, successful offensive. Approximately 40 battalions were committed to their lower Mekong operations. The KC failed to achieve their objectives in 1973-1974 because of an ineffective command and control apparatus, a lack of strategic mobility and poor communications security. These shortcomings combined to cause commitment of units in an uncoordinated, piecemeal fashion allowing an unexpectedly aggressive FANK force to respond effectively. They also experienced munitions shortages and an inability to replace casualties, particularly those in key positions. In the successful 1975 New Year's offensive, the KC were much better organized and even though faulty command and control continued to result in some missed opportunities, their adherence to the overall strategy of depriving Phnom Penh of its

[REDACTED]

[REDACTED]

[REDACTED]

Lower Mekong IOC prior to the all-out direct assault on the capital itself was prosecuted effectively.

The KC also improved their logistics support dramatically. In addition to large amounts of captured/abandoned materiel, they were apparently assured by the NVA of increased weapons and ammunition stocks as well as the transportation assets to move them. In addition, many of the local distribution problems which hampered their activities in the past appear to have been successfully worked out. The KC ability to pound Phnom Penh, Pochentong and Neak Luong, with continuous fire attacks during the final offensive attests to this newly acquired sustaining capability. Initiation by the KC of extensive mining operations on the Lower Mekong not only further demonstrated their increased levels of logistical support, but achieved sufficient surprise and effectiveness to eventually seal the Mekong. Moreover, the KC continually demonstrated a superior ability to replace the massive personnel casualties experienced during the final months of the war. The sum total of these improved logistics capabilities enabled the KC to press their successful attack far longer and much more relentlessly than ever before.

### C. CONCLUSIONS

The final KC success on the battlefield was never assured until the last days of the war. Yet, it was readily apparent during the KC New Year's offensive that they had the requisite logistical support and will to press for a solution favorable to them.

While little is known for certain about the Khmer Communists, it is apparent that their leadership by the end of the war was most effective in planning, coordinating and executing multi-unit combat operations in pursuit of an effective strategy. Their ruthless organization of occupied areas and mobilization of every population and transportation resource therein assured them of sufficient impressed recruits to replace the massive personnel losses inflicted by government firepower; it gave them control over a series of effective, albeit tenuous, local lines of communications, and it drove masses of refugees to the government side, forcing the GKR to provide for them from ever-dwindling food supplies--thus further complicating the government's war effort, in spite of the apparent political advantages accruing from this massive "vote with the feet."

In summary, throughout the Wet Season-Dry Season ebb and flow of the war, there developed a tendency on the part of the GKR to overestimate KC abilities, while the KC, for a long while, underestimated the resolve and staying power of its enemy. When coupled with gross inefficiencies on both sides, this situation led to a series of stand-offs. By 1975, the KC apparently developed a much more healthy respect for the firepower and will of the FANK, planning and executing their

[REDACTED]



[REDACTED] [REDACTED]

maneuvers accordingly. Conversely, PANK's respect for KC capabilities remained low, based on earlier insurgent failures; hence they entered the Dry Season generally underestimating their opponent. In five years of war, the KC came into its own as a substantially matured military force. The GKR/PANK did not.

### III. THE GKR/PANK

#### A. NATIONAL STRATEGY

By default, the military objectives of Lon Nol operated as the GKR national strategy. There were three phases involved:

Phase I: Retention and solidification of territory and population centers under GKR control while building and training the armed forces.

Phase II: Spreading GKR control to all territory and population south of a line extending from the Thai border generally along routes 6 and 7 to the RVN border.

Phase III: Reconsolidation of the nation by moving north from the line to regain control of all GKR territory and population.

By 1974 the strategy was reduced to the purely reactive-defensive effort required to achieve a modicum of Phase I. While moderately ambitious offensive plans were from time to time discussed, none were implemented and national survival became the national strategy. The means to that end were conceived to be demonstrable control of the national capital, provincial capitals south of the Lon Nol line, and some workable system of lines of communication between them.

This strategy of survival was particularly important for external consumption. That is, apparent control and palpable success as a government were mandatory in the GKR's quest for continued recognition on the international scene, particularly the all-important political battle to save the GKR's United Nations seat in September-October, 1974. Demonstrable survival was also a key to the continuing struggle for continuation of US military and economic assistance in the amounts required to sustain it.

#### B. PERFORMANCE AND PROBLEMS

During the period covered by the report, considerable progress was achieved in many areas of the Khmer military establishment. On several occasions during 1974, the Khmer Army properly employed its significant firepower and strategic mobility advantages to defeat the enemy in several engagements. The performance of armor units was particularly outstanding, demonstrating the effectiveness of US training on a segment of the Khmer officer corps.

[REDACTED] [REDACTED]

[REDACTED] [REDACTED]

KAF, for its part, developed into a thoroughly competent tactical air force capable of effective close air support which further increased FANK's overall firepower, while providing an ever-increasing tactical airlift capability, as well. KAF was maintained at or near its authorized strength and benefited by a constant infusion of US-trained pilots and maintenance personnel. Increased strike and transport sortie rates throughout 1974 reflected its growing capability, but it was understandably never able to completely replace the firepower provided by the USAF prior to August, 1973.

The most critical element of the MNK, its thoroughly professional riverine forces, although finally decimated and immobilized by a superior enemy ground force dominating the river banks, nonetheless provided, for a considerable period, security of the Mekong River lifeline. In addition, the MNK progressed markedly as a self-sustaining force, capable of conducting independent supply, maintenance and training activities. On the other hand, the BFM's suffered from extremely weak leadership and were poorly trained.

In spite of the many improvements achieved, there existed severe debilities in the FANK war-fighting effort which continued to resist all efforts at correction or amelioration. These problems finally combined to bring about the defeat of the Armed Forces and contributed to the collapse of the GKR.

(1) Leadership, Command and Staff

The unevenness of effective leadership throughout all levels of command, and at certain echelons, its total absence are unquestionably the prime determinants of GKR/FANK failure. Decision-making was highly centralized. Consequently, subordinates had little encouragement to exercise initiative and the normal process of developing leaders was severely inhibited. Moreover, established chains of command and staff relationships were more often than not bypassed, especially where important matters were concerned.

The Commander-in-Chief of FANK was also the Chief of Staff. His effectiveness as Armed Forces Commander (CINCFANK) was restricted by an unfortunate, but intentional, lack of rapport between the military and civilian sectors of government. In addition, Marshal Lon Nol occasionally issued orders directly to field commanders, bypassing CINCFANK and EMG entirely. As a result, the general staff was constantly frustrated and cautious, while field commanders berated EMG for inactivity and lack of support. In addition, field commanders, many of whom owed their jobs directly to the Marshal, particularly the independent regional military commanders, ignored directives to the extent they believed politically expedient. CINCFANK was thus placed in the role of mediator and negotiator rather than Commander-in-Chief, all of which resulted in a time-consuming, cumbersome decision-making process at the highest levels of command.

[REDACTED] [REDACTED]

[REDACTED] [REDACTED]

At lower levels there was some notion of command, but none of leadership or management, except in isolated cases. Too few battalion and brigade commanders lived in the field with their units. Senior leaders and staffs seldom, if ever, visited units two echelons below. Unit leaders were quick to report that they ordered something to be done, but were at a loss to give any current status, since they rarely checked on the performance of a subordinate, a practice thought to be indicative of a lack of trust and confidence in the individual concerned.

### (2) Discipline and Esprit

These gross leadership shortcomings quite naturally had an undermining impact on the morale, esprit and battlefield discipline of the Khmer soldier, sailor and airman. Despite flagrant absences of their officers in critical actions, long periods without pay or food because of their officers' incompetence, disinterest or dishonesty, and the unimaginative tactics they were all too frequently ordered to execute, it is a tribute to the Khmer soldier that he fought so well for so long. However, these leadership failings finally manifested themselves during the 1975 Dry Season in exceptionally high desertion rates, particularly among new recruits. With foxhole strengths of most units at or below forty percent of that authorized, chronic desertion was a devastating blow to the Khmer Army.

Most elements of the MNK and KAF maintained generally excellent esprit until the final weeks. Among the BFM which, if anything, suffered poorer leadership and training than similar Army units, desertion was rampant, especially when the first real contact with the enemy was experienced in early January along the lower Mekong choke points. Riverine forces successfully withstood a tremendous initial onslaught of casualties, particularly to skilled sailors, until morale finally cracked under the prolonged punishment in late February. Although the KAF experienced increased cases of absenteeism with the rising intensity of rocket and artillery attacks on Pochentong, KAF pilots, ground crews and security forces alike were among the last vestiges of organized GKR resistance.

### (3) Implementation of Plans/Policy

The Assistant Chief of Staff of Operations was the sole individual responsible for country-wide day-to-day operations as well as near-and long-term planning. He had neither the staff, nor the information to make proper decisions in a timely fashion. There existed a particular lack of appreciation for time-distance factors, the actual readiness posture of particular units, limitations on transportation and the other logistics aspects involved in combat operations. This lack of accurate information, coupled with the leadership debilities noted earlier, resulted in an almost total inability to translate even the best of plans into well-executed operations. Implementation was likewise hampered by the necessity for "arrangements", that is, for negotiation between commanders and staffs concerning the number of troops, level of support, and other operational matters which should

[REDACTED]

[REDACTED] [REDACTED]

have been decided by the commander based on recommendations of his staff, then carried out faithfully by subordinate commands. This penchant for "horse trading" rendered timely, coordinated response to operational contingencies practically impossible.

(4) Interservice Coordination.

The Air Force and Naval commanders were almost totally independent and the lack of a real joint staff at EMG led to poorly coordinated military actions when more than one service was involved. Although MEDTC had, in mid-1973, convinced FANK senior leaders to co-locate a DASC and an FSOC with G-3 Operations, the Assistant Chief of Staff for Operations continued to place uncoordinated requirements on the other services and rarely found out if they had been met until too late to have a timely impact on a particular operation. Further, MEDTC strongly urged the establishment of a true joint staff; but only well into the latter stages of the disastrous 1975 Dry Season did CINCFANK start on a regular basis meetings between his staff and the other service component commanders as well as insist on placing permanent Navy and Air Force senior representatives at EMG Headquarters. In the area of fire support at the operational level, KAF and the artillery never really achieved mutual, coordinated action. Either air or artillery support, but never both simultaneously, was the rule.

(5) Personnel and Manpower Management; Recruiting

Inability of the Khmer Army to maintain anything close to combat effective strengths, especially in the intervention units, was a direct cause of its defeat. A reluctance to purge its ranks of phantom soldiers or wholeheartedly adopt improved personnel management techniques even under constant urging by MEDTC, when coupled with increasing desertions, and an inability to return WIA to units expeditiously, yielded a massive personnel drain over and above ever-increasing combat related casualties. Gains simply could not keep pace with losses. Deviations from MAP-approved force structures continued to exist in spite of strong MEDTC objections and the withholding of MAP support from such units. In addition, overstrength headquarters elements were swollen by personnel and equipment diversions from combat units which further sapped their strengths. Only at the eleventh hour did FANK attempt to come to grips with its manpower management responsibilities.

Both civil and military authorities were slow to move on proposals to enhance recruiting, and general mobilization, which had been consistently urged in the past, was not considered until late March—too little, too late. Neither the Navy nor Air Force had significant numbers of phantoms, nor did they experience recruiting problems, largely because their illicit income augmentation came not from payroll padding, but extracurricular use of their available transportation assets.

(6) Military Pay

[REDACTED] [REDACTED]

[REDACTED]

A prime reason for corruption at all grade levels was that pay was inadequate to meet the needs of the servicemen and their families in the highly inflationary GKR economy. Enlisted personnel from all services and their families moonlighted in some fashion, often at the expense of their primary jobs, in order to make ends meet. MEDTC proposed various pay reforms, including a restructuring which favored the combat soldier, establishment of a centralized pay system and a joint US/PANK Military Budget Committee to develop viable solutions to pay problems. Although limited progress was achieved and, at MEDTC urging, a major pay raise/reform instituted, Khmer lethargy in dealing effectively with this problem led to yet another cause for diversion of precious personnel and equipment assets. The un- or underpaid serviceman chose to misuse MAP-funded property, augment his personal income on government time, or desert, rather than see his family starve. That the Khmer leadership generally chose to line their own pockets before considering their fighting men is best evidenced by the fact that phantom soldiers were always paid before the real ones—even when there were insufficient funds available to do both.

#### (7) Support

By 1974, the combat support and combat service support organizations of the PANK had shown marked improvement, and an austere, yet adequate, level of supplies was available to sustain combat operations in each service. Although overall replacement of combat equipment was insufficient to replace losses, declining strengths in Army units rendered resupply adequate overall. Reduced funding prevented the completion of the Army's combat service support organizations; therefore, much maintenance had to be accomplished out of country which was expensive and time-consuming. The Khmer Army did not, in fact, achieve adequate levels of maintenance which, combined with the inability to replace attrition losses, exacerbated an overall marginal materiel quantity and condition situation. The KAF maintenance effort also relied heavily on out-of-country support as well as in-country civilian contract expertise. Until the crunch of Mekong operations overcame it rapidly in February, MNK had developed an effective in-country supply and maintenance activity. Each of the services suffered from inefficient distribution and illicit diversion of supplies—the concept of "government owned" property was never thoroughly developed among the Khmer, particularly an officer corps which was often more devoted to personal gain than the overall team effort.

The level and complexity of the US support effort was never fully understood nor widely appreciated by the PANK. Even late in the divisive US Congressional debate over continued MAP-CB funding, the Khmer were incredulous that the US cornucopia could ever be exhausted. That attitude could well be understood in view of the magnitude of support provided—\$462 million or 216,256 short tons in ammunition items alone were issued during the period January 1974-April 1975. Meanwhile, the largest and longest US supported aerial delivery effort in history was undertaken to augment, and when it became necessary, replace the traditional Mekong River supply lifeline. POL, too, repre-

[REDACTED]

[REDACTED] [REDACTED]

mented a huge, complex logistics effort, amounting to over \$10.9 million in FY 1975 alone. In order to create more efficient Khmer use of these expensive commodities, MEDTC continually pressed for effective ammunition conservation and a cessation of POL diversion. A lack of training in ammunition logistical management within the Khmer services was attacked by over 215 MEDTC ammunition-oriented End Item Utilization Inspections (EIUI) to thirty-one different field locations between May 1974 and April 1975; third country national (TCN)-contract experts were introduced at depot level to assist and train the Khmer, and FANK staff organization and general attitudes were changed over time so that significant improvements in storage, accountability, handling and issue procedures as well as in unit level ammunition conservation activities were achieved. Into-plane refueling and establishment of a fuels control board were introduced to combat POL losses.

#### (6) Training

The basic training course of six weeks for the Khmer Army was too short; too much of the training was devoted to formal instruction and political indoctrination, too little to practical exercises like patrolling. As a result, the soldier was ill-prepared for combat, leading to high casualties and desertions among new recruits. Training facilities were adequate, but were underutilized training plans were unimplemented, specialized in-country training courses always undersubscribed. Selection of Khmer students for the much better US or Thai training was not necessarily based on merit or need, but on often corrupt and inefficient priorities. Upon their return from CONUS or third country training, there was little assurance that students would be assigned to jobs for which they had been trained.

The KAF relied almost entirely on CONUS and later on Thai-based MIT's for instruction of its air crews and key maintenance personnel, although in-country on-the-job training was employed. The MNK trained cadres and specialists primarily in the US, and, prior to disruption of the effort by direct fire attacks on their training facilities, had developed an effective in-country system. Combined arms training was to the end non-existent.

#### C. CONCLUSIONS

There is no doubt that FANK made some management and tactical progress in many areas during 1974. However, progress was too slow and some problems too profound for early resolution. Time was not in the FANK camp particularly in view of uncertain US funding. FANK's immaturity, woefully uneven leadership and resultant inefficiency were major factors in its own demise. "Both the GKR and FANK lacked the managerial sophistication required to participate in the formulation of a national strategy, to translate such a strategy into clearly enunciated operational objectives, or to responsively orchestrate national resources in pursuit of those objectives"

[REDACTED] [REDACTED]

Organizational change was continually crisis-driven and impending disaster the only impetus for institution building. For this reason, many of the new bodies and institutions took on the character of centralized organs crafted onto a decentralized nervous system. Even the moderate success enjoyed by some of these—inter alia, the Joint Manpower Management Committee, Joint Ammunition Control Office, Joint Transportation Board—was achieved largely because MEDTC members who sat on each of them provided the decision-making capacity and necessary presence to achieve temporary solutions to the most pressing problems. To the western military mind, probably the most startling Kmer trait was an almost total lack of any sense of urgency. Attempts to prompt rapid response to any tactical contingency almost universally met with total frustration. Even at the height of the KC New Years offensive, with the fate of the GKR in the balance, and the KC pressing the attack nearly every night, the senior officer awake past midnight in the EMG combat operations center was likely to be a lieutenant colonel or a major, totally unqualified to make any operational decisions. Perhaps the provision of modern accoutrements of war simply outstripped the FANK ability to effectively assimilate them.

#### IV. US POLICY, OBJECTIVE, PROGRAMS

##### A. OBJECTIVES

The initial US objectives in Cambodia were not so much directed at any long-term solution to the Cambodian insurgency as they were to the short-term objective of insuring the success of Vietnamization. Compared with the initial, longer-term approach taken by the DRV of creating a viable KC main force organization, the US was at a disadvantage from the outset.

By the beginning of 1974, the minimum US objective had become a negotiated settlement between the KC and the GKR. Achievement of that objective necessitated continuous demonstration of GKR survivability, if not viability. National survival in turn meant holding the capital and major enclaves against enemy encroachment, while at the same time providing minimum necessities and some economic stability to the population under government control. All of this required protection of a strategic LOC, a battlefield stalemate and continued US military and economic assistance, so that the KC would be faced with the prospect of a long-term, no-win proposition.

The MEDTC role in achieving that objective was to administer and direct the Military Assistance Program, a task which involved developing a close working relationship with the FANK at all levels; determining FANK needs and capabilities; coordinating the transfer of MAP material and services; reporting on the utilization of the equipment provided and providing the focal point for information on MAP-CB.

##### B. PERFORMANCE, PROBLEMS, LIMITATIONS.

###### (1) Congressional Restrictions

[REDACTED] [REDACTED]

in excess of the amount finally authorized (\$200 million for FY75). Management philosophy radically shifted to severe retrenchment and an eventual request for supplemental funding.

In order to provide a modicum of continuity to the program in spite of the funding constraints, and assuming that absolutely essential ammunition would be made available, the decision was made in late December to maintain all non-ammunition lines at the bare minimums required to get through until 30 June 1975, expressing the entire remaining program shortfall in days of ammunition supply. Since the ammunition pipeline was full and 60 days' stocks prepositioned in Thailand, last-minute funding decisions could best be accommodated in ammunition lines.

However, by 7 February, with notification that all funds under the authorized CB-MAP ceiling of \$275M were exhausted, this philosophy had clearly been overtaken by the following events. First, the severe restrictions placed on the use of Section 506 draw-down authority granted by the President reduced its flexibility to the point where available funds could not be applied to the lines in which they were most needed. Second, the FY75 authorization legislation directed a series of heretofore undeducted charges to MAP-CB. The final blow was the enemy's successful interdiction of the Lower Mekong. The initial and very expensive failures to break the blockade, followed by total reliance on civilian contract airlifted resupply for Phnom Penh and on airdrop for most enclaves, resulted in massive added PCH&T costs chargeable to MAP-CB.

To finance these sizeable unprogrammed aerial delivery costs, a drastic overall reassessment of the remaining MAP-CB open lines was immediately conducted, and continued throughout the Team's last two months of in-country operation. Generally, this day-by-day reprogramming effort involved cancellation of all longer lead-time items in favor of basic operational commodities, transportation assets, and any critically needed attrition/investment items which could be made available and delivered in the short term. Even this management effort was continually frustrated by a practice analogous to a run on a failing bank. The total amount of funds remaining was drained at both ends, as the various DOD agencies, from which MAP-CB had acquired goods or services since 1971, scrutinized their accounts and submitted their belated, but nonetheless valid, claims against the rapidly dwindling dollar amounts available. Program lines could not be drawn down to zero balance in view of possible delayed billings and resultant over-obligations. The effect of these factors, coupled with the inherent lag time between a MEDIC line manager's obligation or program change action and its final posting at the military departments, was to frustrate the very day-by-day program management made necessary by the dearth of funds. Quite clearly, the MAP/PPES was not designed for, nor is it completely adaptable to, an operational combat environment.

[REDACTED] [REDACTED]



[REDACTED] [REDACTED]

In January 1971, the Cooper-Church Amendment specifically prohibited "advisors" in Cambodia, The Symington-Case Amendment of February 1972 prescribed that the total number of US personnel in Cambodia should not exceed 200. In view of the US Vietnam experience, the intent of these restrictions is understandable. However, their cumulative effect was to severely limit any MEDTC ability to ensure that millions of dollars in MAP funds were being well spent. FANK was provided modern equipment but was denied the overall training, technical know-how, and military professionalism desperately needed to modernize it in the areas of tactical leadership, staff planning and coordination, personnel and financial management or logistics operations. Proper management and effective use of the equipment provided was apparently to be learned by a trial and error, do-it-yourself process which time would not permit.

Lacking any authority to provide in-country advice or US training, any improvement in FANK leadership was predicated on almost non-existent Khmer initiatives since American officers were too restricted to assist. The most important US training contributions possible were through return of CONUS and Third Country US-trained officers. While these cadres made a marked impact on the élites of the MNK (riverine forces) and KAF (aircrews), the small numbers possible had no significant impact on the Army.

The 200-man "headspace" ceiling for the US Mission also precluded any flexibility in reacting to new requirements such as the vastly expanded civilian airlift, in March-April 1975, without severely crippling other, ongoing efforts. The overall effect of the ceiling was a US Country Team personnel mix based on the nature of the current crisis with consequent ill-effects on program continuity.

## (2) Reliance on Firepower

FANK was originally conceived as a "light infantry force" designed to fight "Khmer Insurgents". When it became apparent that the "insurgents" were rapidly evolving into main force units in their own right, the US objective of keeping FANK alive and the GKR viable was assured through the quick-fix of massive US airpower. With the US bombing halt in August 1973, the Khmer Army artillery and tactical air inventories were augmented because this solution provided less expensive and politically more palatable sources of firepower to offset the leadership and manpower deficiencies in the Khmer Armed Forces. As that firepower was increasingly denied to them because of escalating munitions costs and reduced funding, the only remaining option appeared to be manpower.

However the Army's inability even to maintain the strength of its intervention brigades, let alone achieve significant growth, soon became self-evident. Moreover, serious leadership and training deficiencies, combined with the absence of any US advisory or training effort, obviated major changes in the Khmer force structure, battlefield tactics or doctrinal reliance on firepower, even if sufficient time had been available.

[REDACTED] [REDACTED]

[REDACTED] [REDACTED]

In sum, the US taught the Khmer Armed Forces to survive through firepower. FANK was equipped with the means to employ it in large amounts. Outside sources of firepower were withdrawn so that they relied solely on their own firepower assets. Firepower and the logistics to support it became the two most important advantages FANK had over the KC, and by 1974 it was too late to change that orientation to any extent in the short term. Therefore, as escalating prices drove munitions costs progressively higher, increasing rather than decreasing levels of MAP funding were necessary to promote successful achievement of US objectives in Cambodia.

### (3) MEDTC Reorganization

MEDTC was originally organized along functional lines with a Plans and Programs Division, a Management Assurance Division and a Logistics Division. This organizational scheme had proven an effective vehicle for discharging earlier MEDTC missions of delivering massive amounts of major equipment items to the Khmer Armed Forces. By August 1974, however, sustaining an existing force structure in hostilities of ever-increasing intensity and service-oriented sophistication became the norm. For that reason, a MEDTC reorganization along component service lines (Army, Navy, Air Force Divisions) was directed and implemented. Because of the singular importance of ammunition, POL and related services a separate, hybrid division was provided as a hold-over from the functional organization, as well as a small overall inter-service coordination agency for planning and programming in the Office of the Special Assistant to the Chief, MEDTC (SACSA).

The new organization almost immediately resulted in much closer coordination between MEDTC and the respective Khmer Armed Forces, one of MEDTC's major responsibilities. It did not, per se, further the growth of a true joint staff apparatus in FANK, which although strongly urged by CHMEDTC, met with initial service reluctance, if not resistance on the Khmer side. The dangers of clientism and incomplete coordination were anticipated, but presented no major problems. Without doubt, the new organization was more responsive to MEDTC's overall needs during the reporting period than its predecessor would have been.

### (4) MAP/CRA Funding.

Initially, FY75 MAP-CB was programmed to obligate as early as possible during the fiscal year for longer lead-time investment items, so as to secure much-needed delivery as soon as possible. The incremental (Continuing Resolution Authority) funding of the program quickly obviated this approach, driving all available funds into operations and maintenance lines, particularly ammunition. By December, 1974, when Congress finally authorized New Obligational Authority for FY75, MEDTC had been spending at a rate (\$70 million per quarter) for nearly one-half of the fiscal year which unfortunately turned out to be forty percent

[REDACTED] [REDACTED]

[REDACTED]

[REDACTED]

### C. CONCLUSIONS

On 16 April 1975, the day prior to the capitulation of the Khmer Armed Forces and the collapse of the GKR, MEDTC from its rear base in Thailand, arranged and controlled six aerial resupply missions into Phnom Penh. Thus, given the narrowest possible interpretation of the MEDTC mission, it was successfully accomplished until the end. But the "end" involved complete failure of the United States' security assistance objective of developing a self-sustaining Armed Force capable of defending the GKR from insurgency. In microcosm, this paradox was with MEDTC from its inception to its disestablishment.

In spite of the myriad of Congressional limitations placed on the Team's activities, the unprecedented program turbulence generated by uncertain funding levels, and the body blow to FANK's morale which negative public debate on increased aid created from as early as October 1974, MEDTC, magnificently supported by higher and coordinate headquarters, successfully accomplished its most rudimentary mission--the logistical support of the Khmer Armed Forces.

Whether by lack of external support or by self-destructive practices within, it is certain that the morale and will to resist within FANK gave way before the material means to do so were totally depleted.

### V. SUMMARY OF CONCLUSIONS

A. A generally corrupt and incompetent officer corps, uneven leadership, an innate lack of a sense of urgency, and fragmentation of authority led to untimely and ineffective decisionmaking in the FANK. These leadership deficiencies either led directly to or were instrumental in most other shortcomings of the Khmer Armed Forces. Firepower, mobility and materiel advantages are no substitute for effective leadership at all levels.

B. Poor manpower management, ineffective recruiting, inability to control desertions or correct military pay deficiencies and failure to ameliorate the "phantom" problem resulted in grossly understrength Army units incapable of performing sustained combat missions. Poorly conceived and improperly executed training, coupled with mal-assignment of trained personnel exacerbated desertions and combat unit strength deficiencies.

[REDACTED]

[REDACTED]

[REDACTED] [REDACTED]

C. The lack of a joint staff in fact, or even joint effort in spirit, caused ill-conceived, poorly planned and frequently uncoordinated joint operations. "Team spirit" in pursuit of common objectives was seldom evidenced by FANK, at any level, despite concerted MEDTC efforts to instill it.

D. Restrictive CRA funding methods; uncertain, tardy and then drastically reduced funding levels; coupled with inflationary prices, did not permit the attainment of the planned force structure, particularly with respect to combat service support units. Procurement of combat loss and attrition materiel was also severely impaired, thereby reducing FANK's combat and combat support capabilities. The MAP/PPBS system is neither sufficiently flexible nor responsive to meet fully the needs of a supported nation in active warfare.

E. The psychological impact of uncertain funding, highlighted by US public debate on its merits, permeated FANK to its lowest leadership levels, with considerable adverse effect on morale.

F. There were too few MEDTC personnel and too many restrictions on their activities for the Team to completely monitor the entire MAP and effectively apply its professional expertise to improving the FANK.

G. Third country nationals and technical assistance contracts, both in-and out-of-country, are indispensable to a MAP effort involving an embryonic host country technical base and severe limitations on the use of US military personnel.

[REDACTED] [REDACTED]

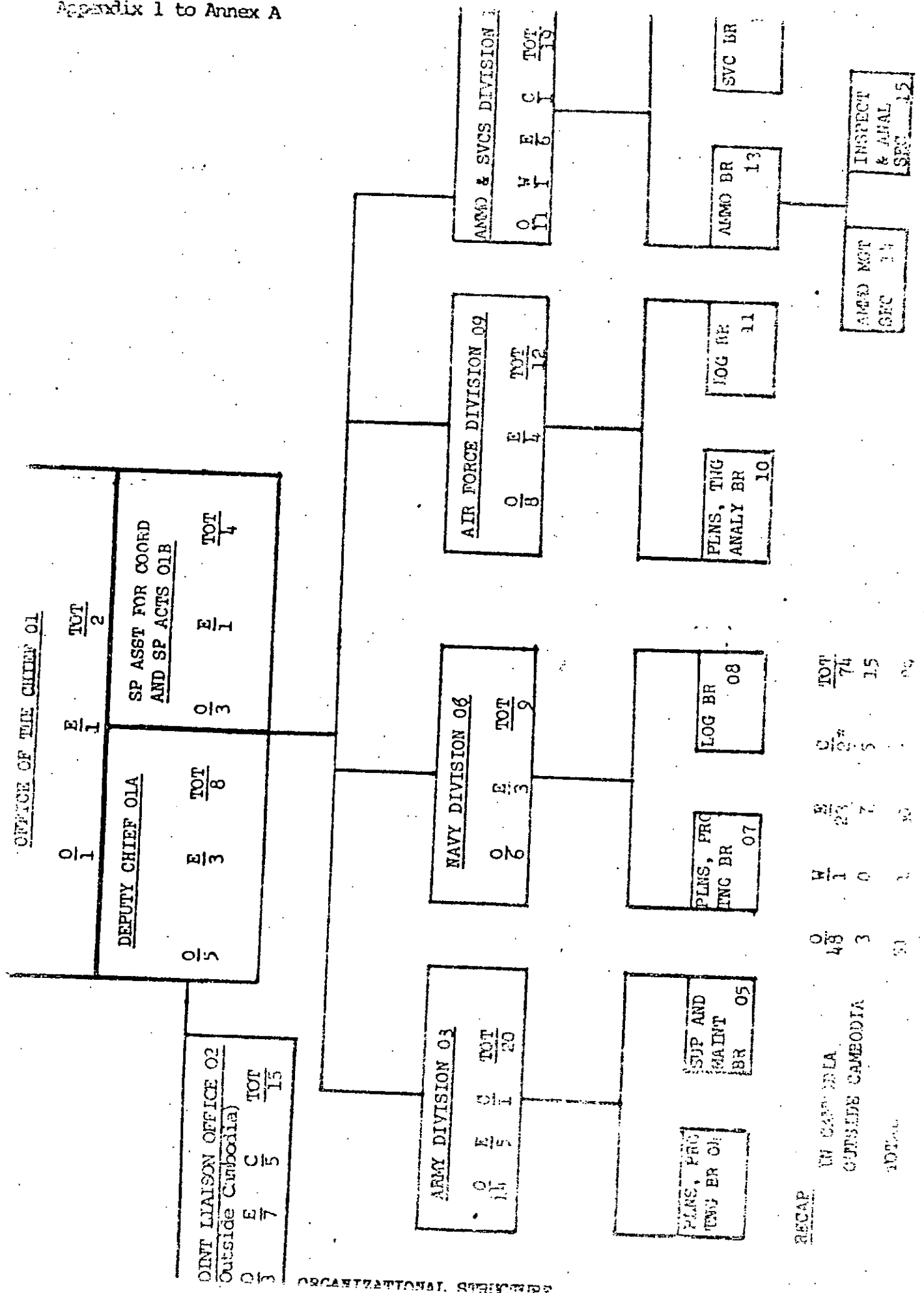

RECAP

	O	E	TOT
IN CAMBODIA	48	23	74
OUTSIDE CAMBODIA	3	0	15
TOTAL	51	23	89

\* LOCAL UNIT

JOINT LIAISON OFFICE, CAMP SAMAE SAN

1. MISSION. The mission of JLO, Samae San, was to perform liaison/ administrative support functions and coordination for Chief, MEDTC which could not practicably be performed in Cambodia, including:

- a. Personnel accounting, procurement, manpower control, personnel service, personal and official mail management.
- b. Records, publications and forms management.
- c. Morale and welfare activities.
- d. In coordination with administrative personnel of the forward element, advising the Chief, MEDTC, on matters relating to administration and personnel management.
- e. Initiation of action to expedite movement of priority cargo when appropriate.
- f. Requesting and documenting movement of US military and civilian personnel on official travel to and from Phnom Penh and students of the Khmer Republic to CONUS or third country for training.

2. ORGANIZATION AND FUNCTIONS: The Joint Liaison Office, Camp Samae San, consisted of one officer who served as both Chief, Joint Liaison office and the Adjutant General of MEDTC. He also served as the liaison officer to HQ USMACV Support Group and other headquarters and agencies located outside Cambodia as required. He was assisted by enlisted personnel with specialties in the fields of personnel/ administration, supply/subsistence and transportation. The manpower authorization of the JLO was austere, in keeping with the manning of the Team. Army personnel support was generally provided in-house by JLO personnel as the Team staffing was primarily Army and the make-up of the JLO was mostly of that service. Personnel and administrative support beyond the JLO capability was provided by USMACV Support Group at the direction of COMUSMACV. Awards, by CINCPAC direction, were forwarded via CINCPAC from the JLO to the respective services. All incoming replacements were processed through JLO in the following manner:

- a. Upon arrival at Camp Samae San they were given an initial briefing and assigned to temporary billets.
- b. During processing, records were checked, travel claims submitted, finance records updated, and ration cards, field clothing and equipment were issued.
- c. After in-processing, the Joint Liaison Office arranged onward transportation to Phnom Penh.

3. PROBLEMS ENCOUNTERED. The split configuration of MEDTC between Camp Samae San and Phnom Penh created problems in providing timely and responsive support between the two areas:

a. Personnel actions were often delayed due to lack of reliable daily aircraft flights.

b. The lack of normal support facilities in the Khmer Republic necessitated the establishment of a weekly commissary run from Bangkok to Phnom Penh and an up-grading of the bi-weekly post exchange service from U-Tapao. This support required a personnel augmentation to JLO.

c. Headspace constraints required the abolishment of the unit property book officer position. Therefore, the property book was maintained by the Supply NCO assigned to the JLO. Due to his location, it was impossible for him to maintain accurate accountability of assigned property in Phnom Penh.

d. As there was no operating APO at Phnom Penh, personal and official mail had to be channeled from Bangkok via US aircraft to U-Tapao for further movement to Phnom Penh. The lack of available C-130 aircraft periodically prevented the timely delivery of mail. Constant surveillance of the mail enroute had to be established to insure movement of mail from Bangkok to Phnom Penh without interruption.

JOINT LIAISON OFFICE, BANGKOK

1. BACKGROUND. From its inception, the Joint Liaison Office, Bangkok, located within HQ USMACTHAI, was an element of MEDTC Management Assurance Division. While charged with many of the functions common to any liaison element at an adjacent headquarters, the principal mission of this office was to support the training of Khmer Military personnel in Thailand by the Royal Thai Government, and to support the movement of Khmer military personnel to and from off-shore training locations. As a result of the reorganization of MEDTC functions, the Liaison Office interfaced routinely with the separate service divisions, in the case of Third-Country training with Army and Air Force Divisions, and in the case of off-shore training with Navy Division as well. The office operated in close coordination with specified MACTHAI staff elements, with the several embassies involved, maintained de facto interface both with Thai Supreme Command Headquarters (Forward) (SCHQ (F)), and, on a regular basis, with dedicated RTA and RTAF schools and training centers. The office paid student personnel, expanded its functions for off-shore trainee personnel in transit to include both initial payments and final TDY payments, and arranged all such off-shore transportation.

The office participated in lengthy negotiations between MACTHAI and Thai SCHQ(F) concerning the FY75 training program, concerning the nature and quality of training and attendant training problems, made payment to the RIG for training performed, and made payments to other agencies. With the loss of the regularly scheduled USAF Bangkok-Phnom Penh flights, the problems involved with transportation of Khmer personnel demanded increasing amounts of time expenditure on the part of the Bangkok office. In support of this operation, the Bangkok office negotiated for and obtained permission to amend ITOs, and subsequently received authority to issue ITOs. Finally, and most significantly, the office was able to expand its functions to include the regular inspection of dedicated RTA and RTAF training facilities, to monitor POIs, and to verify the quality of training received. It further supported and arranged for the visits of MEDTC project officers to Thai training facilities in an effort to further the objective of training verification. The supervision and validation of Third-Country training became the primary mandate of the Bangkok office.

2. MAP. This office had no direct dealing with Khmer executive agencies or policy-making staffs. It did, however, amass a great amount of experience in dealing with individual Khmer students, and student groups, with military grades ranging from Lieutenant Colonel through Sergeant. Several characteristics were observed with disquieting frequency. The first of these was that the nomination of specific individuals for Third Country training was driven by considerations which appeared to have little relationship to the war effort. Third-Country trainee personnel arrived in Thailand without possessing the prior skills required by the course of instruction. Third-Country trainee personnel frequently appeared to lack

[REDACTED]



[REDACTED] [REDACTED]

any significant personal motivation for the subsequent employment of military skills acquired in Thailand, and all too often appeared in little likelihood of being assigned, on return to the Khmer Republic, to positions requiring the exercise of those skills. Third-Country trainee personnel appear to have been nominated for training, by DGI or by their parent organizations, as a reward for prior individual performance (of some nature), and Third-Country training was perceived all too frequently by the student as a respite from combat, or from Cambodia, and as an opportunity to profit from the attractions of the Thai economy. Motivation for training was frequently less than desirable. This attitude often characterized entire classes. Generally, technical service and enlisted personnel were better prepared for and motivated toward training than were personnel of the combat arms and officers. Discipline was weakest among officer trainee groups.

3. KHMER LEADERSHIP. The GKR maintained in Bangkok, at considerable expense, a FANK liaison office, located at Thai SCHQ(F). This office, headed by a Khmer Army Colonel, was comprised of six officers. Its mission was to exercise an effective command function for Third-Country trainee and support personnel, and, in addition, to represent Khmer interests with the Thais in regard to Third-Country training. Consistently, in the experience of this office, the FANK Liaison Office was wholly derelict in both functions.

4. FUNDING. This office was not involved in programming of funding but did make or arrange all payments effected in Thailand in support of Third-Country training of Khmer personnel by the Thai, and in support of off-shore trainee personnel transiting Thailand, to include the payment of final TDY payments to such personnel and for the medical treatment of such personnel at civilian medical facilities. In support of this function, the Bangkok office identified funding requirements, requested funding authority, and expended authorized funds, maintaining appropriate documentation. This office was continuously involved with training cost negotiations with staff elements of Thai SCHQ(F), and some observations concerning the negotiations for the FY75 Training Program should be made. It would appear in retrospect, and has been suggested by a number of Thai sources, that the lengthy delay between the original MEDTC FY75 program request, in May 1974, and receipt of a Thai program proposal in November 1974, was the result of political conflicts extant between civil and military elements of the Thai government, specifically between the Foreign Ministry and Thai SCHQ(F). The Thai government has exhibited considerable instability and confusion of purpose, since the former government was deposed in October 1973. Visits by this office to schools and training centers indicated that HQ RTA did not begin normal staffing with these activities until very late. Following the November submission, further delays in the negotiating process were experienced as the apparent result of the desire of HQ RTA to obtain for the proposed services all remuneration that the traffic would bear.

5. RELATIONSHIP WITH OTHER AGENCIES. Relations with all agencies during the period, except in the case of the FANK INO, remained excellent. These

[REDACTED] [REDACTED]

[REDACTED]

agencies included various staff elements of HQ MACTHAI, the US, Khmer and Philippine Embassies in Bangkok, USAID, DTL, USAF 6th Aerial Port, elements of MACTHAI Support Group, staff elements of Thai SGIQ(F), and with the various dedicated RTA and RTAF schools and training centers. It should be noted that the MACTHAI staff element charged with Third-Country training, MACTIN (formerly J-34), did not tend to share MEDIC's concern for verification of the quality and relevance of purchased training, perceiving its primary interest to be negotiation. This reluctance was perhaps due in part to the fact that, during much of this period, that office was staffed by USAF personnel while the primary thrust of MEDIC Third-Country training in Thailand was Army-oriented.

6. KC NEW YEAR'S OFFENSIVE. The offensive served ultimately to strangle the Third-Country program, principally in its understandably disruptive effect on student selection, student availability, and student mustering processes, all of these internal to DGI and to FANK. Some Third-Country trainee movement took place, and all services continued to send out scheduled personnel for off-shore training.

7. CRITICAL PROBLEM AREAS. The lack of personnel skill identifiers, the quality and nature of the student selection process, and the matter of student motivation, were, taken together, the most critical immediate problems bearing on Third-Country training at any given time. Another problem also had considerable influence on this program--the long-term suitability of Thailand as the site for such training. The immediacy which impelled the transfer of Third-Country functions from RVN to Thailand is well understood, and the then extant Thai government appeared to offer considerable policy commonality with the aims of the USG. Certainly the obvious advantages of proximity to Cambodia (hence lower transportation costs for MAP-CB) and minimization of culture shock on the trainee obtain equally to Thailand as to South Vietnam. The potential for instability of that Thai government, or of later governments, however, might or might not have then been a relevant consideration. Of more immediacy for a satisfactory training program was another consideration--the historical and cultural enmity between Thai and Khmer. Time and again this office was informed during the course of training visits to the field and in frank and confidential discussion with Thai military authorities, that it was difficult for local training agencies to give maximum effort to the training of former, and potentially, future enemies of the Thai State. However, this same reservation might well have applied to earlier Third-Country training in RVN.

[REDACTED]

[REDACTED]

ARMY

1. INTRODUCTION.

The defeat of the Khmer Army in April 1975 was not inevitable. It was not due to a single event or policy, but was the result of multiple causes. The following analysis of the Army's defeat begins a year before the event, in the Khmer Dry Season of 1974, and leads up to 1 January 1975.

2. 1974 DRY SEASON.

Survival of the GKR appeared to be in doubt from February through April of 1974. The US bombing halt in August 1973 deprived the Khmer Armed Forces of an important firepower advantage over the KC. Although FANK was being augmented with additional howitzers and armored personnel carriers to partially offset the loss of firepower, it was not known if delivery and training would be timely enough to halt the KC Dry Season Offensive. In addition, the Khmer Air Force was embryonic and even a US-sponsored training program and build-up of aircraft would take months to achieve an effective tactical air force. In February, the southern sector of the Phnom Penh perimeter was seriously threatened. Pochentong airport was the object of a determined enemy drive. Additionally, the enclave of Kampot was facing a serious attack. FANK strategy at this stage was little more than a day-to-day struggle for survival. In March, the KC efforts appeared to have run out of steam and another year's life for the GKR seemed to have been won. The Nixon administration had secured additional funds for military assistance and plans were laid for the forthcoming Wet Season.

3. THE SOLDIER.

The Khmer soldier is a sturdy, rugged fighter who appears to thrive on adverse living conditions and danger. These fine soldierly qualities are well known to those American officers who served with Khmer units in Vietnam, most of whom place the Khmer foot soldier far above the Lao and at least on a par with the Vietnamese. It is a tribute to this soldier that units of the Khmer Republic's Army lasted as long as they did under some of the poorest leadership in Asia. Despite the flagrant absence of their officers during critical actions, the failure of their top leadership to even visit them or recognize their heroic deeds, the long periods that they and their families went without pay or enough food because of their officers' incompetence or dishonesty, and the unimaginative tactics that they were ordered to execute, Khmer foot soldiers continued to fight for their country until defeat was inevitable. The KC leadership proved the Khmer soldier capable of well-executed night attacks and, as a normal course, demonstrated the ability to avoid or withstand superior firepower.

[REDACTED]

#### 4. LEADERSHIP.

The structure of the colonial Cambodian Army was basically a French officer cadre and Khmer soldiery; little effort was made to provide a system to produce competent Khmer officers. The small, 30,000-man Cambodian Army of the 1950's and 1960's had no immediate requirement to train an officer cadre capable of providing the backbone of an expanded armed force. However, in 1969, the Cambodian Army, previously devoted to civic action projects and border patrol, was pitted against NVA and VC units in several sharp border incidents. Its leadership proved unequal to the task as Cambodian Army units were decisively defeated.

The almost universal response to what was regarded as a war against the Vietnamese brought enthusiastic young men to the Army in 1970, many capable of being developed into promising leaders. However, when the conflict evolved into a long civil war with decreasing support for the military from the government and local populace, the motivation of this group of young Khmer leaders was seriously eroded. Additionally, rapid promotion of young, combat-proven leaders was largely denied since the ill-trained peacetime officer's corps was elevated en masse in 1970 and 1971, effectively closing off key leadership positions to young combat-experienced officers. The KC leadership, having a lesser number of peacetime leaders, was able to develop through trial and error, insuring promotion to those who proved themselves in combat and were dedicated Communists. The pre-war FANK officer cadre usually relied on their own group, rather than searching for new talent, resorting in one case to the award of a brigade command to an officer previously carried as a deserter, and the appointment by Marshal Lon Nol of his personal choices to key command positions. MEDTC inspections often found large-scale officer absenteeism, usually noted a lack of troop supervision, and little indication of enthusiasm by the majority of Khmer officers. U.S. training had only a marginal impact, since many trainees were selected for non-military reasons and were subsequently malassigned on their return. An important exception was found in Khmer armor units, where a significant number of key officers were US-trained. The lack of an advisory role constrained in-country US actions, thereby depriving the Khmer Army of training in fundamentals of leadership. Although not able to advise, MEDTC inspectors noted unit shortcomings, reports of which were passed to the appropriate FANK agency or discussed by CHMEDTC with CINCFANK. However, a break-up of the pre-war officer clique was not achieved and an improved system to develop and assign officers was not implemented.

#### 5. COMMAND AND GENERAL STAFF.

The Commander-in-Chief of FANK was also the Chief of Staff. His role as CINCFANK was somewhat restricted, due to a lack of rapport between the military and civilian elements of the government which was partially his fault. In addition, the Marshal frequently gave direct orders to commanders, such as

[REDACTED]

[REDACTED]

the Special Forces Commander and the Air Force Commander, without prior consultation with CINCFANK. Commanders at the brigade and higher level were often personal selections of the Marshal. These restrictions, coupled with the almost total independence of regional military commanders, placed CINCFANK in the role of mediator and negotiator rather than commander-in-chief and resulted in an unresponsive, cumbersome decision-making process at the highest levels of command.

The Air Force and Naval commanders were almost totally independent, and the lack of a real joint staff at EMG led to poorly coordinated military actions when more than one service was involved. Although MEDTC convinced FANK senior leaders to co-locate a DASC and an FSCC with G-3 Operations, the Assistant Chief of Staff for Operations continued to place uncoordinated requirements on the other services and rarely found out if they had been met until it was too late to have a timely impact on a particular operation. MEDTC also pushed the establishment of a true joint staff, but, only during the latter stages of the disastrous 1975 Dry Season, did CINCFANK start, on a regular basis, meetings between his staff and the other service component commanders, as well as insist on placing permanent Navy and Air Force senior representatives at FANK Headquarters. This measure was welcomed by both KAF and MNK commanders.

The creation of a US/FANK Joint Transportation Board, which met daily, was the first positive step in inter-service planning. Preceded by a briefing/update on military operations (past, present and future) this daily meeting immeasurably helped the services to coordinate and prioritize US and FANK air as well as Khmer riverine and land transport assets for the most efficient movement of personnel, equipment and supplies. This effort achieved maximum effective utilization of these scarce resources and gave the government forces a decided strategic mobility advantage over the KC. The best example of this advantage was the rapid, timely movement of most of the intervention brigades from the provinces to Phnom Penh in early January 1975; these reinforcements were indispensable in stopping the initial KC onslaught.

The Assistant Chief of Staff of Operations was the sole individual responsible for country-wide day-to-day operations, as well as near and longer range planning. He was neither staffed to handle, nor did he insist on receiving, timely reports from the field on which valid decisions could be made and acted upon. There was a serious lack of appreciation of time-distance factors, as well as the limited capabilities of transport and other logistic activities. He was assisted by a BG in the Operations Center, but, during the height of the Dry Season Campaign in March, the Assistant Chief of Staff for Operations became sick due to fatigue and there was a critical void in the conduct of operations for Phnom Penh. Additionally, the Operations Center focused on Phnom Penh, leaving operational matters elsewhere largely in the hands of Military Region commanders, all fighting for scarce resources. The Assistant Chief of Staff for Operations tried to meet their requirements rather than establishing priorities, which led to a frittering away of resources.

[REDACTED]

[REDACTED]

In order to gain greater control and efficiency in the conservation of ammunition, which consumed over 80% of MAP funds, an Assistant Chief of Staff for Munitions was created. By centralizing the various ammunition activities under one staff element, greater control over issues was achieved. By prioritizing daily consumption rates in coordination with G-3 Operations, significant savings were realized without hampering military operations. The system was flexible enough to meet the needs of changing tactical situations and forced the G-3 Operations to establish priorities for planned operations.

Strategic plans were not followed due to the inability of CINCFANK to command or at least have operational control over all forces - land, sea, and air. There was no true joint staff and operations involving more than one service were planned at the last minute by senior commanders with little previous and subsequent staff action. The Assistant Chief of Staff for Operations tried to maintain operational control over all ongoing operations as well as to personally direct the defense of Phnom Penh. His staff did not have sufficiently trained personnel to provide continuity in the Operations Center with respect to this multitude of tasks.

#### 6. SUPPORT.

By 1974, the combat support and combat service support organizations of the Khmer Republic's army had shown a marked improvement, and an austere yet adequate level of supplies was being received to sustain combat operations. The overall delivery level of combat equipment was not sufficient to replace losses within combat units; however, since the strengths of these units continually dropped during the year, in-country supply levels for most essential items were generally adequate. Reduced funding prevented the completion of adequate combat service support organizations and much maintenance had to be accomplished out of country which was costly in funds and time. The Khmer Army did not achieve an adequate level of maintenance and this, along with the lack of funds to purchase replacement items, exacerbated the overall condition and quantities of materiel available to combat and combat support units. In addition, inefficient distribution and theft precluded many units from obtaining adequate numbers of uniforms, boots, and, in some cases, weapons.

Funding for the army's supplies and equipment was MEDTC's responsibility. Few Khmer officers were aware of the difficulties of paying for a war under CRA and inadequate funding. However, the force structure of the army had largely been organized and equipped and the supply pipeline was in operation. Funding was, then, an American headache and had only some impact on Khmer operations, which could continue as long as supplies could be brought into the country. Support of a war under constrained and uncertain MAP funding was inefficient, but it was not an impossible task and was not a major factor in the defeat of the Khmer Republic's army since overall it was better armed and better supplied than its adversary.

[REDACTED]

[REDACTED]

The Republic had been provided with hundreds of thousands of weapons; stock-piles of arms were constantly being found by MEDTC and FANK inspectors. However, each stock had an individual "owner", a unit or subdistrict commander who treated all equipment as personal assets; the concept of government property for a common cause was largely non-existent among an officer corps that was devoted to personal gain rather than to a team effort. In addition, Military Region Commanders diverted newer MAP-provided equipment to territorial and auto-defense units at the expense of intervention units who bore the brunt of the fighting. It was, therefore, practically impossible to redistribute any significant number of weapons and other equipment. Rather than allow willing and able soldiers to go unarmed, some additional weapons and equipment were programmed in FY 74 and 75 to increase combat effectiveness. Transportation equipment continued to deteriorate in the army, as no additional trucks were bought during FY 75. A lack of organizational level maintenance and enemy mines caused many brigades to drop from an authorized twelve 2 1/2 ton trucks to only five or six operational, yet no major battles were lost because of the lack of an ability to move troops, ammunition, or supplies. Decreasing strengths, shrinking perimeters; an adequately equipped transportation brigade, and an improved Khmer Air Force airlift capability provided the means to move the army during 1974. The backbone of the communications system for the army was the PRC-25. Rough handling and combat losses kept these sets in short supply; however, no major battles were lost for lack of communications equipment and again, the decline in unit strengths and some new procurement of PRC-25s assured a generally adequate distribution of radios throughout the war. The army was therefore able to shoot, move, and communicate better than its opponent.

## 7. TACTICS.

The tactics used by the army of the Khmer Republic reflected the lack of professionalism of the officer corps and their failure to actively seek innovative solutions to their particular situation. Defense was attempted by establishing a perimeter composed of small mud forts spaced at approximately every two kilometers. Such a defense was dependent on cleared fields of fire, on active day and night patrolling to disrupt infiltration, and accurate, indirect fire to prevent enemy concentration - none of which the army did well. Friendly attacks were almost always conducted during daylight hours by forces that were assembled from their defensive positions and usually had limited objectives such as retaking a lost outpost or position. Since movement was rarely conducted at night, offensive actions usually started at 1000-1100 hours and ceased by mid-afternoon to prepare defensive positions. If friendly forces had not attained what they regarded as defensible terrain, they would frequently withdraw to their original positions for the night. This process was often repeated for days, resulting in unnecessarily high losses and sapped morale in the units. Most units would not continue these types of attacks after 72 hours and had to be replaced. Fire support, particularly air,

[REDACTED]

[REDACTED]

was often executed too far in advance of the actual assault and was therefore ineffective. Coordinated fire planning was rare. The attack was usually conducted using an infantry skirmish line, officers well to the rear with armored personnel carriers, when available, employed 200 meters back in a traveling overwatch or overwatch position. If enemy resistance was stiff, the attack halted and all available firepower was employed. Use of envelopments was usually avoided, since such maneuvers required coordination of combat support forces. If a second advance met determined resistance, the path of least resistance was usually taken by terminating the attack and subjecting enemy positions to bombardment. There were some cases of successful innovative assaults; however, the normal attack of the Khmer Republic's army was characterized by a dull, plodding, belated advance, devoid of surprise, coordination or innovation. When the enemy chose to resist, friendly casualties were high and objectives rarely attained.

Unable to advise, train or use their professional abilities, American officers could only observe this needless waste of good Khmer soldiers. Hope for tactical success was based on the superior firepower of government forces. If artillery and tactical air support had been sufficiently improved, it could partially have compensated for the ineffectiveness of unit infantry leadership on the battlefield. Unfortunately, FANK officers made little effort to use trained forward observers and were just starting to use air observers for the adjustment of artillery fire. Most artillery fire was adjusted by battalion commanders or was unobserved and often executed on out-of-date intelligence information. Air strikes were usually unexploited and the effectiveness of T-28 and gunship sorties was usually unknown.

#### 8. TRAINING.

The basic training course of 6 weeks duration was too short. MEDTC's position was that 8 weeks should be the minimum. Too much of the training was devoted to political indoctrination and formal instruction, too little was devoted to practical firing exercises, care and cleaning of equipment, patrolling (day and night), combat training of the individual soldier, field fortification, and other practical work. As a result, the soldier was generally inadequately prepared for his tasks on the battlefield, leading to high casualties and early desertion. NCO and officer training was also slanted toward the theoretical rather than the practical. The Khmer Republic's military leadership also failed to devise, or implement to the degree necessary, their own training plan, and failed to correct deficiencies noted on the battlefield by their own and MEDTC inspectors. In addition, many basic trainees only received 3-4 weeks training and NCO courses were always undersubscribed. Combined arms training was non-existent. Selection of Khmer students to receive U.S. or Thai training was poor and FANK collusion often led to selection of the favored few. Efforts by U.S. officers to improve FANK training programs were consistently frustrated by high-level apathy on the part of the Director General of Instruction and his staff.

[REDACTED]



[REDACTED] [REDACTED]

9. PERSONNEL MANAGEMENT.

Lack of adequate manpower was undoubtedly one of the major causes of the Army's defeat. A reluctance by the Army to purge its ranks of phantom soldiers seriously undermined the combat effectiveness of intervention and territorial units. MEDTC had proposed several measures to improve personnel management and reduce phantoms: a centralized ID card and dog tag issue program to prevent local forgeries and payroll padding; automation of personnel and finance rosters to build an accurate personnel data base for strength accounting; increased emphasis on recruiting to include elimination of draft deferments for a large segment of the eligible population; establishment of an MOS system; and several concrete recommendations to stem the enormous number of desertions--a significant drain of trained manpower. Both the civil and military sectors of the Khmer Government were slow to move on the politically unpalatable proposals, with the result being less than the required number of troops at the front. Personnel gains could not keep pace with the total losses, a problem which the Khmer Rouge apparently did not have. In addition to an inaccurate and unresponsive casualty reporting system, there was no real understanding of how long a WIA would be combat ineffective. Because of the limited medical treatment facilities available, it is estimated that only 35-40 percent of the approximately 1,300 WIA per week during the 1975 Dry Season were returned to duty. General mobilization, which had been strongly urged by the US Mission early in the Dry Season, was not considered seriously by government leaders until late March, too little and too late.

10. PAY.

Pay at all grade levels was totally inadequate to the needs of the soldiers and officers and their families in a highly inflationary economy, which condition led directly to corruption and desertions. Commanders kept the names of deserters, MIA, and KIA on their active payrolls and used the money for various unit welfare needs, purchase of supplies and equipment, and for personal gain. Soldiers were often far busier gathering firewood, fishing, or farming, than manning or improving their defensive positions. Technical personnel only worked a 30-hour week so that they could earn money on the civilian economy to support their families. Military vehicles, aircraft, and naval craft were sometimes diverted for financial gain. Some supplies and equipment, to include POL products, were sold on the local market or to units. MEDTC proposed various pay reforms, such as a centralized pay system and a Joint US/FANK Military Budget Committee to establish a sound military budget procedure and to propose solutions to pay problems. Although some progress was made in these areas, it was too late to sufficiently cure the existing illnesses. US civilian officials often did not agree with military pay increases due to possible inflationary pressures on an already strained economy.

[REDACTED] [REDACTED]

[REDACTED]

11. FORCE STRUCTURE.

By mid-1974, the force structure for a 220,000-man FANK force was complete, except for headquarters and support organizations above division level. Serious deficiencies existed based on failure to provide necessary maintenance and logistic units, such as Direct Support Ordnance Companies, which were repeatedly thrown into shortfall because of funding constraints. Deviations from MAP-approved organizations did occur--such as creation of the 9th Division (Presidential Guard) despite strong MEDTC objections--and resulted in diversion of personnel and equipment, thus weakening existing divisions. In addition, authorized and provisionally created headquarters were overstrength and were not MAP-supported, thereby reducing the effective strength of authorized combat and combat support units and reducing equipment (radios, etc) available to them. A major deficiency was the failure of FANK to exercise effective manpower management; it was too late by the time a comprehensive program to examine the force structure was initiated in December 1974.

12. US GOALS.

In accordance with the US policy of obtaining a negotiated settlement, the army of the Khmer Republic had to achieve only a stalemate on the battlefield rather than a clear-cut victory. Hopefully, enough of an edge could be secured over the KC to begin regaining ground that had been lost during the war, so that the KC would be faced with a situation of irreversible decline and thereby agree to early negotiations with the GKR in a position of strength. Improvement in the leadership and combat effectiveness of the government's army was totally dependent on Khmer initiative, as American officers were too few and completely foreclosed by legislation from assisting. The most important US training contribution was being made by returning Khmer graduates of CGSC and the branch schools; however, the introduction of this small number of officers did not make a significant impact on the army. During 1974, achievement of the US goal would have to be secured by superior firepower and a hoped-for improvement in the Khmer leadership base.

[REDACTED]

[REDACTED] [REDACTED]

### 13. THE KHMER COMMUNIST ARMY.

The Khmer Communist army was characterized by determined, totally dedicated, intelligent leadership; innovative approaches to tactical problems; and ruthless discipline. Unhindered by an inexperienced peacetime officer corps, the Khmer Communists and their North Vietnamese advisors promoted officers on performance in combat, and arrived at skilled, proven leadership. Strategically, their efforts in 1974 were directed at applying pressure on the GKR enclaves with the objective of drawing government troops from Phnom Penh, to be followed by shifting their main effort to the Phnom Penh perimeter. The KC failed in 1974, due to a lack of strategic mobility and poor communications security which allowed the Republic's army to define probable targets, alert local forces, and move reinforcements in time. Tactically, the KC achieved concentration of forces by resorting to dispersed patrols, stand-off attacks by fire, and the seeding of minefields in unoccupied areas in order to mask their maneuver and make discovery of their withdrawal costly. They also moved effectively at night and most of their major attacks occurred at night, often between 2300 and 0200 hours. During 1974, their determined tactical defense techniques were improved by increasing use of the B-10, B-40, and B-41 launchers to destroy or deter armored personnel carriers. These weapons were employed behind an RPD machinegun-swept minefield that would break up government infantry. Minefields were usually composed of the simple metallic Chinese antitank mines protected by newer, small plastic Chinese anti-personnel mines.

The KC had become increasingly adept at surviving air and artillery attacks by quickly digging well-camouflaged, protective emplacements at each halt. They had learned well from their Vietnamese advisors, but the KC had not been able to achieve the degree of mastery with mortars for which the VC and NVA are famous. Their night operations were highlighted by infiltrating government positions, by pinning down the defenders in their positions with heavy attacks by fire, followed by a ground assault. By dawn their gains were consolidated and enough excavation had usually been achieved to withstand 105mm artillery fire and T-28 attacks. By the end of 1974, the KC were improving their communications security, in some cases using deceptive messages to key government forces on false information. During 1974, the KC were also able to recruit sufficient personnel to maintain their strength in spite of heavy combat losses. In addition, they improved their span of control by creating additional battalions, regiments, brigades, and divisions from within their existing force level. They also improved their lines of communication and transport capabilities and were thus able to move greater numbers of personnel and larger amounts of supplies and equipment more rapidly, sometimes achieving strategic and tactical surprise. The KC did not have a large combat support force, but impressed into service the population under their control to perform many of the required logistical services. It should be noted, however, that approximately 10% of their forces were required for population control to prevent large scale defections to the government side. The Communist army, therefore, was an improving one, learning how to survive superior firepower and to exploit the weaknesses of the Khmer Republic's army.

[REDACTED] [REDACTED]

[REDACTED] [REDACTED]

14. 1974 SUMMER COUNTERATTACK.

The last portion of the 1974 Dry Season saw the Khmer Republic's army successfully defend its besieged positions and regain some of its lost territory. On the south coast, the intensive siege of Kampot began to ease in April and the KC gave up this attack in May; by this time, all attention had shifted to the RN5-Oudong-Lovek complex north of Phnom Penh. Oudong had fallen to the KC in mid-March and FANK efforts to retrieve this politically important town had been countered. By April, Lovek was under pressure, but in May, FANK infantry and artillery units, well supported by armored personnel carriers, began a steady, determined attack to relieve Lovek and retake Oudong. Constant fighting in June saw FANK get the upper hand, retake most of RN5 to Oudong and lift the siege of Lovek. On 11 July, Oudong was retaken and 200 KC were killed in their unsuccessful counterattack. FANK had demonstrated an improved coordination of combat arms and a significant degree of tenacity and drive under fire. The performance of armor units was particularly outstanding. This area, with a heavy infusion of US-trained officers, proved that a US training effort could upgrade the performance of Khmer officers. The prospects for the 1974 Wet Season appeared to be bright. The army of the Khmer Republic had successfully defended and repulsed determined enemy attacks on Kompong Cham, Kampot, Lovek and Phnom Penh without US air support and had staged a successful counterattack up RN5 to Lovek.

15. 1974 FALL OFFENSIVE.

The initial GKR strategy proposed for the 1974 Wet Season envisioned a simple order for all units to attack in sector. The goal was to place KC units under constant pressure, to regain a fertile section of land between the Mekong and Bassac rivers southeast of Phnom Penh--the Upper Bassac Corridor, and concurrently to remove the 107mm rocket threat against the capital. This strategy was revised in July when it was pointed out that any strategy that did not envision regaining a secure route to the rice-rich Battambang region failed to address the vital need to improve the precarious economy of the Republic and missed the opportunity to sever a prime KC LOC. The initial attack of the season belatedly commenced in September, the Army leadership having frittered away the entire month of August in celebrations and repose. The assault in the Bassac corridor met with early success because the KC had removed most of their forces from the Phnom Penh region for refitting and retraining. However, the KC managed to construct a successful Bassac defense in October with limited forces. The government forces continued to attack, taking an increasing number of casualties while gaining small amounts of territory. FANK was also able to reopen RN5 from Kompong Chhnang to Battambang and effect passage southward of large rice convoys. The Summer and Fall of 1974 had demonstrated that the Khmer Republic's army could coordinate their arms and successfully conduct attacks and defend gained territory. An important enemy weakness had also been demonstrated - the apparent lack of strategic mobility made the KC vulnerable to being "whip sawed." The requirement was for FANK to gain the initiative, press a combined arms attack in one sector, then

[REDACTED] [REDACTED]

[REDACTED]

shift rapidly to another sector once the KC managed to assemble a successful defense. Such a plan was conceived for the Dry Season of 1975, but never implemented.

16. 1975 DRY SEASON.

The Bassac offensive had been conducted by phasing into Phnom Penh almost one-half of the Republic's intervention brigades, so as to reduce the number of casualties received by any one unit. As a result of continually pressing this attack, infantry unit foxhole strengths had dropped from an average of 55% to an average of 45% by December. The territorial gains were not commensurate with the cost, since no significant advance had been made since October. The KC had successfully countered the offensive and it was now obviously time to use the FANK's mobility advantage to shift the offensive. The chosen area for the attack was RN5 between Lovek and Kompong Chhnang. This attack would hit an enemy sector already known to be depleted by reason of the KC need to reinforce the Bassac area and his retraining of substantial forces in the vicinity of Kompong Cham. It was also far enough away from enemy concentrations so that the initial advantage in strategic mobility could be exploited before resistance could be organized. It would sever an important enemy LOC and thus insure bringing about a battle in an area favorable to FANK, since the chosen battlefield could be influenced by riverine forces and armored personnel carrier units and was located between two centers of GKR strength. In order to secure this advantage, the offensive would have to begin by 15 December, as the Bassac operation was grinding to a close and the KC were preparing for their Dry Season offensive. Although the need for urgent action was repeatedly considered by the Khmer general staff, FANK moved at the same pace as their previous Wet Season performance--one month late. A successful, early, RN5 attack would undoubtedly have upset the KC timetable and diverted forces destined for Phnom Penh, in that it would have cut the major East-West LOC of the enemy. This was the turning point in the transition from the Wet to the Dry Season campaigns of 1975 and a major tactical turning point of the war.

17. THE KC NEW YEAR'S OFFENSIVE.

The 1 January 1975 enemy attack took government forces by surprise. The enemy had greater quantities of ammunition and weapons available, had improved their communications security and command and control of their forces, and had conceived and executed an intelligent, well-balanced plan designed to pin down the forces of the GKR in the Phnom Penh perimeter.

[REDACTED]

[REDACTED] [REDACTED]

They cut the vital Mekong supply route, using barriers and mine fields in the river. The leadership of the Khmer Republic's Navy gave up the Mekong corridor without a fight instead of tenaciously reinforcing key BFM river bank positions. The army, bled during the Bassac operation, had failed to sufficiently recruit and reduce desertions and was immediately locked in a bitter duel to save Phnom Penh. Reinforcements were quickly flown into Phnom Penh, but were not sufficiently numerous to relieve and reinforce units on the Mekong at the same time. By mid-January, it was obvious that the first half of 1975 would probably prove to be the decisive point of the war. Despite the fact that infantry unit strengths were falling to as low as 30%, the GKR deferred taking stern action against deserters and declined risking alienation of the middle class by curtailing student deferments and clamping down on those who bought their way out of service. Efforts were eventually started in February to reopen the Mekong and, in an extremely costly campaign, the Republic's Navy was decimated to the point of being combat ineffective, while six of the total thirty-two intervention brigades were one-by-one rendered combat ineffective or captured.

By March, MEDTC had reprogrammed enough funds and recovered enough prior year monies to pay for vital ammunition, rice, and airlift to last until the last week in April, but, as government infantry units continued to fail in counterattacks, it appeared that defeat might well come prior to exhaustion of supplies. As the end drew near in April, the past sins of Lon Nol's officers began to take their toll. The lack of any spirit of teamwork became more apparent when units refused to operate with adjacent commanders, in some instances actually asking for money to conduct attacks in conjunction with other units. One battalion commander in Siem Reap turned pale when his reportedly full strength unit was ordered to deploy to Phnom Penh; he had carried over 400 lucrative "phantoms" on his payroll roster, but in reality only had 40 combat effective troops. Officers in Battambang were helpless when hitherto weak enemy units began a surprisingly successful offensive; the preponderance of "phantoms" and absence of capable leadership precluded any reasonable defense. The lack of professionalism and leadership within the officer corps, as well as the chronic epidemic of unit officer absenteeism insured that the increasing tide of desertions would not be stemmed. The lack of a sense of urgency and discipline in compliance with orders continued and contributed to late morning counterattacks that failed to secure defensible ground before dusk, resulting in needless retreats and the same costly efforts being made on the next day. These flagrant failures in the Republic's officer corps cost the loyalty of the Khmer soldier to his government and wholesale unit failures began. The army of the Khmer Republic had possessed the soldiers and the material means to succeed, but the Republic did not possess the leadership necessary for the task. Additionally, the Khmer Communist army proved itself to be a determined, intelligently led foe, one that was devoted to improvement and innovation. Finally, the restrictions placed on the American officers who served in the Khmer Republic precluded the use of their considerable skills in directing, training and assisting the Republic's officer corps.

[REDACTED] [REDACTED]

[REDACTED]

CONCLUSIONS.

1. On several occasions during 1974, the Khmer Republic's Army demonstrated that well-led troops, exploiting their strategic mobility and firepower advantages, could defeat the enemy. However, indecisive Khmer Army leadership, a lack of a sense of urgency, and a fragmentation of authority led to untimely, burdensome decision-making. A glaring example was FANK's failure to seize the initiative at the outset of the 1975 Dry Season, an action which might have pre-empted the KC offensive.
  2. A generally corrupt and incompetent officer corps did not provide the leadership required to successfully pursue the war effort, in spite of having numerical and qualitative advantages over the KC in manpower, equipment, supplies, and mobility. A US capability to correct this major flaw would have been contingent on authority for MERTC to assist in the identification and development of Khmer leaders, a task requiring additional personnel and a charter to advise and train.
  3. The MAP system is neither sufficiently flexible nor responsive enough to meet the needs of an Army at war. CRA funding, reduced budgets, and inflationary prices did not permit the attainment of the complete force structure, particularly with respect to combat service support units. Procurement of combat loss and attrition materiel also was not achieved, thereby reducing the Army's combat capability. Uncertain funding contributed to a lack of offensive spirit in the top leadership of FANK. Procedures do not presently exist for program flexibility and timeliness of response to rapidly changing situations.
  4. Poor manpower management in the primary areas of recruiting, desertions, and phantoms created understrength units not capable of performing their missions during sustained combat operations. Improper assignment of trained personnel denied their much-needed expertise to FANK.
  5. In spite of adequate facilities, individual and unit training was poorly conceived and improperly executed, leading to high casualties and early desertions.
  6. The reluctance to organize a joint staff and failure to cooperate between the Army, Navy, and the Air Force led to frequently uncoordinated and sometimes marginally successful joint operations. The FANK general staff, particularly the J-3 Operations, was neither sufficiently manned nor professionally qualified to focus both on operations country-wide and within the Phnom Penh perimeter.
  7. Pay was inadequate and the soldier frequently was paid late or only received a partial payment, thereby creating serious morale implications as well as a need for "moonlighting".
  8. Units such as Special Forces and Psychological Warfare organizations were not employed in their proper roles, although there was a need for their special capabilities in the overall war effort.
- [REDACTED]

KHMER INFANTRY

1. BACKGROUND. Khmer infantry units composed almost 80 percent of the Khmer Army. Approximately 75,000 troops were authorized in the intervention brigades, the rest being territorial units. In February 1974, these units were inspected at the rate of about three battalions per week by MEDTC personnel. A central MEDTC EIUI (End-Item Utilization Inspection) office coordinated the inspections; inspecting officers were from all branches. Beginning in April, the expansion of ammunition inspections absorbed the limited officer personnel available at the expense of the infantry inspections. Since there was no corresponding Khmer office that actually conducted systematic inspections, no infantry inspections were conducted during the Spring and early Summer of 1974. In July 1974, a new infantry inspection program was approved by CHMEDTC and the Defense Attache. In order to recommence inspections without jeopardizing the ammunition inspection program, a joint inspection team composed of a MEDTC infantry officer and an assistant Army attache began. These inspections were conducted at the rate of two to three per week and were only directed at the intervention infantry units. They were conducted from July 1974 until April 1975. Although repeated efforts were made to have knowledgeable Khmer officers accompany the inspections, the General Staff consistently failed to show any interest in visiting or inspecting the condition of their infantry units. The IG office and G-4 office did conduct inspections; however, they were mostly of a property accounting nature. The MEDTC inspections were conducted to determine: the tactical situation and deployments; personnel status; equipment status; and the general condition of troops on the ground. They served as a source of information in determining MAP training and materiel requirements. Additionally, these inspections were invaluable in arriving at priority lists for issue of scarce items. Since the Khmer General Staff took little interest in the inspections, CHMEDTC began writing monthly letters to CINCPAC on inspection findings. A report of each infantry inspection was filed in a brigade file and circulated through MEDTC staff elements for appropriate action.

The tactics used by the Army of the Khmer Republic reflected the lack of professionalism of the officer corps and their failure to actively seek innovative solutions to their particular situation. Defense was attempted by establishing a perimeter composed of small mud forts spaced at approximately every two kilometers. Such a defense depends on cleared fields of fire, on active day and night patrolling to disrupt infiltration and accurate, indirect fire to prevent enemy concentration--none of which



[REDACTED]

the Army did well. Friendly attacks were almost always conducted during daylight hours by forces that were assembled from their defensive positions and usually had limited objectives, such as retaking a lost outpost or position. Since movement was rarely conducted at night, offensive actions usually started at 1000-1100 hours and ceased by mid-afternoon to prepare defensive positions. If KC forces would not withdraw, government forces would frequently withdraw to their original positions for the night. This process was often repeated for days resulting in unnecessarily high losses and sapped unit morale. Most units would not continue these types of attacks after 72 hours and had to be replaced. Fire support, particularly air, was often executed too far in advance of the actual assault to be effective. Coordinated fire planning was rare. The attack was usually conducted using an infantry skirmish line, officers well to the rear, with armored personnel carriers, when available, employed 200 meters back in a traveling overwatch or overwatch position. If enemy resistance was stiff, the attack halted and all available firepower was employed. Use of envelopments was usually avoided, since such maneuvers required coordination of fire support forces. If a second advance met determined resistance, the normal recourse was to terminate the attack, fall back, then subject the enemy positions to bombardment. There were some cases of successful, innovative assaults; however, the normal attack of the Khmer Republic's army was characterized by a dull, plodding, belated advance, devoid of surprise, coordination or innovation. When the enemy chose to resist, friendly casualties were high and objectives rarely attained.

Khmer infantry did not know how to use indirect fire, either artillery or their own organic mortars. Mortar crews, both 81mm and 60mm, used the gun-target method of fire instead of the target-grid method. Unfortunately, enemy targets were usually unobserved by the crew leaders, thus causing inaccurate, wasteful fire. Additionally, the misuse of ammunition in defensive positions of the infantry contributed to the high cost of MAP-CB ammunition supplies. Troops normally used five to ten M-16 cartridges to start their cooking fires and ammunition was removed from wooden containers in order to provide construction material for living quarters. Machineguns were often poorly maintained and employed in positions that provided only the most restrictive employment of the weapon. These deficiencies--waste of ammunition, lack of an ability to employ organic indirect fire weapons, poor siting and care of the machinegun, and a lack of any adequate training program were the logical consequences of poor leadership, characterized by large-scale officer absenteeism, apathy and ignorance.

The Khmer infantryman is a sturdy, rugged fighter who appears to thrive on adverse living conditions and danger. These fine soldierly qualities are well-known to those American officers who served with Khmer units in Vietnam. Most of these officers place the Khmer foot soldier far above the Lao and at least on a par with the Vietnamese. It is a

[REDACTED]

[REDACTED]

tribute to this soldier that units of the Khmer Republic's Army lasted as long as they did under some of the poorest leadership in Asia. Despite the flagrant absence of their officers during critical actions, the failure of their senior leaders to even visit them or recognize their heroic deeds, the long periods when they and their families went without pay or enough food because of their officers' incompetence or dishonesty, and unimaginative tactics that they were ordered to execute, Khmer foot soldiers continued to fight for their country until the last. The KC leadership proved the Khmer soldier to be capable of well-executed night attacks and, as a normal course, of avoiding or withstanding superior firepower. Thus, it is clear that the willingness, resolve, and capability of the basic Khmer soldier cannot be cited as factors in the defeat of the Khmer Republic's Army. The failings of the Khmer infantrymen were the result of his lack of supervision, training, and leadership of his officers.

The Communist infantry was characterized by determination, intelligent leadership and innovative tactical approaches. Unhampered by an inexperienced peacetime officers corps, the Khmer Communists and their North Vietnamese advisors could promote officers on performance in combat, and thus built a skilled, proven leadership. In order to concentrate forces and mask movements, the KC employed dispersed patrols, used attacks by fire, and erected minefields in areas that had been evacuated. During 1974, their determined tactical defense techniques improved by the increased use of the B-10, B-40, and B-41 launchers to destroy or deter the government's armored personnel carriers. These weapons were employed behind an RPD machinegun-swept minefield that could break up infantry advances. Minefields usually consisted of the simple metallic Chinese anti-tank mines seeded with the newer, small plastic Chinese anti-personnel mines.

The KC had become increasingly adept at surviving air and artillery attacks by quickly digging well-camouflaged, protective emplacements at each halt. They had learned well from their Vietnamese advisors, but the KC had not achieved the degree of mastery with mortars for which the VC and NVA are famous. KC attacks were usually night operations, infiltrating government positions by pinning down the defenders in their foxholes with attacks by fire. Concentrating on one position, attacks would usually begin with a barrage from B-10, B-40 or B-41 launchers, followed by a ground assault. By dawn their gains were consolidated and enough excavation had usually been achieved to withstand 105mm artillery barrages and T-28 attacks. The Communist infantry was thus improving, learning how to survive superior firepower and exploit the weaknesses of the Khmer Republic's Army, without aircraft or significant amounts of indirect fire.

[REDACTED]

[REDACTED]

2. MAP. The MAP system as practiced in the Khmer Republic was inadequate to support infantry units in combat. The lack of an ability to advise severely hampered efforts to improve Khmer infantry. Since the Khmer were not under any obligation to follow US suggestions, they rarely asked for badly-needed professional opinions, and none could be volunteered. The lack of an in-country US-controlled training facility deprived the Khmer of badly-needed expertise and placed infantry training requirements in the hands of those with little knowledge of front-line needs. Infantry materiel requirements were crucial to the morale and success of FANK initiatives. The lack of responsiveness of the MAP system was often responsible for belated delivery of unfilled needs. Even when funds were available, there were constant delays in supply of badly-needed ponchos, clothing, and boots. Since the MAP system feeds into a US supply system and the few in-country US personnel were required to manually record each supply request, the Khmer had to adapt their supply system to the US system. Most Khmer infantry units were completely unprepared to define their requirements or request needed supplies. The austere MEDTC manning level was inadequate to oversee the needs and performance of the Khmer infantry, in that only one officer was primarily responsible for this vital function, but only on a part-time basis.

3. KHMER LEADERSHIP. Expanded rapidly in 1970 from a small, inexperienced cadre, the Khmer infantry leadership initially received a large group of enthusiastic young leaders who joined to fight the VC/NVA. When the war had evolved into a civil war by 1974, the motivation for this group was removed and the burden of leadership fell on the pre-war officer, often ill-prepared, ill-trained, and not respected by the Khmer citizen, partially because of FANK's reputation of corruption. No comprehensive leadership program was instituted to upgrade the quality of the officer corps. Promotion was secured by pre-war association and loyalties, while enemy leadership selection was evidently made based on combat success. The end result was a FANK infantry leadership cadre that was incapable of preventing desertion of its troops; incapable of executing a modicum of successful attacks against the enemy despite overwhelming firepower and the presence of the fine, sturdy Khmer foot soldier; incapable of appealing to the Khmer citizen and obtaining the required popular support in order to defeat the KC; and finally, incapable of devising a system to improve its officer corps by purging its ranks. The Khmer infantry officers often were well to the rear during combat action or in some cases absent. They saw to their personal needs first and their troops second. A good example of this was that almost invariably, Khmer infantry units robbed ambulance jeeps for parts in order to keep the officers' personal jeeps running. Ingenuity among these officers was usually restricted to building their own office or quarters; battlefield tricks or successful ploys against the enemy were rare. The normal technique against the enemy was to use massive firepower and inch forward by day, while the Khmer Communist frequently achieved success in his night attacks.

[REDACTED]

[REDACTED]

The largest single problem created by corrupt practices in Khmer infantry units was the creation of "phantoms" in order for officers to gain additional funds for unit welfare, purchase of supplies and equipment and personal gain. At its worst, this practice presented the General Staff with seriously undermanned units, which were thought to be combat worthy. Notable examples were attacks on Kompong Chhnang in October of 1974, Battambang in February 1975, and Siem Reap in January 1975, where woefully undermanned units were besieged by the KC. It must be kept in mind, however, that the GKR faced a 200-percent-plus yearly inflation, and, whereas an officer could afford a home and a car in 1971, he had to sell them in 1974 to feed his family unless he gained funds from sources other than his normal pay and allowances.

4. FUNDING. Lack of sufficient funding caused inventories of critical infantry items to drop to extremely low levels in 1975. Entire brigades were operating with 30 to 40 radios and 5 or 6 trucks. Thus, the original FANK materiel advantage over their enemy was rapidly disappearing. However, since the GKR failed to recruit successfully, FANK had less need for substantial amounts of individual equipment. The most difficult aspect of funding was the inability to plan because of the lack of knowledge of when, and in what quantity, funds were to be made available. The occasional doles of CRA funding; the lateness of the appropriation of fiscal year funds, even the dramatic 500 percent inflation in the price of some machineguns, all worked to preclude an intelligent management of funds for the support of Khmer infantry, the backbone of FANK. Even when funding was available, the supply system was often unresponsive to combat requirements. Lead times in shipment of many infantry items were as much as two years. In order to cut these times, extraordinary efforts and constant message traffic were essential on the part of the few available personnel assigned to MEDTC. Such efforts inevitably detracted from other important duties.

5. RELATIONSHIP WITH OTHER US AGENCIES. The prime US agency associated with Khmer infantry other than MEDTC was the Defense Attache's Office. Four attaches were designated primarily to overwatch the four Khmer infantry divisions, totalling 12 infantry brigades. Their prime duty was to report on activity. On the other hand, the 20 independent brigades were not as closely observed; thus, when coordination was required between MEDTC and DAO on a recommended supply priority, the independent brigades were often slighted. In addition, some 60,000 auto-defense personnel, who often fought as infantry, were out of the area of responsibility of MEDTC, this program being under the stewardship of the Politico-Military portion of the US Embassy. Consequently, these units were rarely inspected by US military and their activities went largely unreported. An example of the latter case was the defense of Battambang in February 1975. Due to the large "phantom" count in the territorial units, the defense of the city relied on auto-defense units, but it was only belatedly discovered that these units were practically without ammunition.

[REDACTED]

[REDACTED]

6. KC NEW YEAR'S OFFENSIVE. Many Khmer infantry units crumbled during the KC offensive. The 36th Brigade, 72nd Brigade, 38th Brigade, 12th Brigade, 4th Brigade, 20th Brigade, and several others either dissolved in the face of enemy attacks or were steadily destroyed in day-to-day action. In four months of fighting, Khmer infantry lost the equivalent of one battalion per day. Khmer infantry officers were incapable of leading successful counter-attacks despite firepower, materiel and mobility advantages. They were incapable of preventing desertions and failed to achieve sufficient recruiting to replace losses. What recruits were obtained often were unarmed due to the inability of the Khmer General Staff to redistribute sufficient available weapons. Starting at an approximately 50 percent foxhole strength in January, most Khmer infantry units were at 30 percent by March. The Khmer infantry was consistently outfought, outsmarted, and outmaneuvered by the enemy infantry during these final days of the Republic.

7. MOST CRITICAL PROBLEM AREAS. The most significant aspect of Khmer infantry was its lack of competent leadership. Associated with this problem was the inability of experienced US officers to assist the Khmer because of the restrictions on numbers, advising, and training. Even if advice and training had been authorized, the MAP system is not conducive to being used as a lever to insist on higher standards. The requirement to title-transfer property on entry into the country precluded its direct issue to deserving units and the withholding of items from corrupt officers or recalcitrant units.

8. CONCLUSIONS.

a. Khmer infantry leadership was generally incompetent and corrupt and the restrictions on the number and authority of US military personnel precluded effective assistance to the Khmer in improving this leadership, either in the selection, training, monitoring, advancement or assignment areas.

b. The MAP system was inefficient in support of combat operations.

c. The method of funding precluded the intelligent planning of procurement.

d. The US mission organization did not facilitate efficient monitoring of Khmer infantry units, other than the 32 intervention brigades.

[REDACTED]

ARTILLERY

1. BACKGROUND. From early 1973 until April 1975, one officer assigned to MEDTC was assigned the additional duty of monitoring over 90 FANK artillery batteries and headquarters. This monitorship spanned all aspects of field artillery.

By the end of May 1974, the FANK artillery organization, caused by the massive introduction of new artillery following cessation of USAF tactical air support, had essentially been completed. From mid-May through December 1974, the major emphasis shifted from equipment input and build-up to organization, training, maintenance, and fire support planning.

2. MAP. Congressionally imposed personnel limitations on Americans were a serious drawback to MEDTC's capability to satisfy EIUI requirements. There were no major problems, however, with respect to MAP follow-on support of artillery.

3. LEADERSHIP. Khmer artillery officers at all levels were inexperienced and not sufficiently knowledgeable in basic artillery principles, tactics, and fire support coordination. There was inadequate supervision at all levels. Headquarters did not function as staffs but rather as a pool of individuals who reacted to the latest order from the commander.

There was a poor relationship and a lack of coordination between BG Sok Son, the Chief of FANK Artillery and Commander of the 1st Artillery Brigade, and the divisional artillery battalions and the artillery of the military regions. Commanders tended to consider the political affiliation and relationship of each individual which was often more important to them than the actual military rank or position of the individual. In addition, there was a very strong resistance to change. For example, FDC procedures were performed in the same ineffective manner as in the past. Officers, newly returned from courses at Fort Sill or Thailand, were quickly told to revert to the procedures and methods that had always been followed-- often the French methods of twenty years ago.

Duty hours for Khmer artillery above the battery unit level, even at crisis times, were from 0630 hours to about 1300-1400 hours; Saturdays and Sundays were non-workdays. There were very few exceptions made.

ARMOR

1. BACKGROUND. During February 1974-January 1975, Khmer Army mechanized units proved to be one of the few effective elements of the ground forces. Major operations attempted without support of mechanized squadrons usually failed to achieve their objectives, even in the defense. Basically organized and equipped as light reconnaissance elements, the mechanized squadrons were used most often in a traveling overwatch or assault role where their high density of automatic weapons and the heavy firepower of their 106mm recoilless rifles gave a significant fire power advantage to Khmer Army Forces. The eight squadrons (troops) in the force structure were generally disposed half in the Phnom Penh area (one per division) and half in the outlying areas. The practice of placing each of the squadrons assigned to the mechanized regiment under the operational control of various military region commanders left the Phnom Penh-based regimental headquarters with no tactical mission, thereby wasting a competent staff organization.

Significant combat actions during the period in which the mechanized squadrons played a major role include: the relief of Oudong-Lovek (May-July 1974), the opening of Route 5 from Pursat to Kompong Chhnang (Nov-Dec 74), and the Wet Season offensive in the Bassac (Sep-Dec 74). The heavy use of these units is graphically demonstrated by the APC combat losses suffered during this period (12 lost, compared to an average of 5 per year from 1971-1973, and 17 requiring evacuation out of country for repair). The heavy use also led to significant maintenance support problems and particularly heavy wear on track and suspension systems. Since the MAP program authorization did not allow for maintenance float vehicles, the result was a steady degradation of the combat power of these units. Out of an authorized strength of 200 M113 type vehicles (including mortar carriers and recovery vehicles), the average on-hand strength was 190, with 165 operational. At the end of December, just prior to the final KC offensive, the on-hand strength was down to 185, with 153 operational.

The approved force structure also called for a tank regiment (Battalion) and a Motorized Regiment, but these units were never operational during the period, except as local security forces for the Armor School at Das Kanchor. This was due to a lack of tanks and trucks necessary for them to perform their primary mission. The Tank Regiment had been equipped with prior - MAP M24 Light Tanks and French AMX-13's; however, by early 1974 these were non-operational due to a lack of spare parts and ammunition. No suitable replacement vehicle was available through MAP nor, for that matter, in the US inventory. The only suitable substitute would have been the M-41 (the M551 being too expensive, complex and unauthorized for MAP programming). The possibility of equipping Khmer units with the M41 or with medium tanks was investigated and rejected due to a combination of political problems, funding constraints, and the lack of long-term supportability in the case of the M41.

[REDACTED] [REDACTED]

[REDACTED] [REDACTED]

An additional function of the FSCC was planning and executing the counterrocket fire program. During late 1974 and early 1975, the artillery was tasked to establish counterrocket observation posts around Pnom Penh under the overall supervision of the artillery and the FSCC. The OP's proved marginally effective; however, based on the data provided, the FSCC coordinated the overall counterrocket program. They also played an active role in coordinating H&I fires with the counterrocket program within the allotted ammunition supply rate.

During the Dry Season Offensive, the Khmer also became more proficient in fundamentals of artillery. Map spots of battery positions were refined with resection procedures; boresight and lay of the batteries were verified daily; maintenance was performed more routinely; and FDCs were providing more accurate and rapid gun data. The French method of using the simple WORM formula to determine gun data was slowly replaced with data computed in the FDC. With the aid of more trained observers, to include air observers, the artillery was beginning to show definite signs of improvement.

#### 7. MOST CRITICAL PROBLEM AREAS.

a. Leadership - the rapid expansion made for poorly trained leaders. There was little sense of obligation to the needs of the soldier.

b. Break-down of authority - Rank and position did not carry the weight necessary to order action; political considerations often governed.

c. Resistance to change - Senior officers were comfortable in their "old ways." Younger officers who had just returned from formal schooling could not always train the members of their units, as they were often hindered by their superiors.

d. Maintenance and Logistics - The US system was complicated and the training provided the Khmer in these areas was inadequate.

#### 8. CONCLUSIONS.

a. Restrictions on MEDTC personnel, both in number and function, did not allow the MEDTC EIUI's to be as effective as they should have been.

b. If the host country's artillery is to be improved and adequate inspections are to be conducted, then Congressional restraints must be relaxed and sufficient artillery officers must be assigned to permit frequent, in-depth inspections on a regularly scheduled basis.

[REDACTED] [REDACTED]



Appendix 3 to Annex B

ARMOR

1. BACKGROUND. During February 1974-January 1975, Khmer Army mechanized units proved to be one of the few effective elements of the ground forces. Major operations attempted without support of mechanized squadrons usually failed to achieve their objectives, even in the defense. Basically organized and equipped as light reconnaissance elements, the mechanized squadrons were used most often in a traveling overwatch or assault role where their high density of automatic weapons and the heavy firepower of their 106mm recoilless rifles gave a significant fire power advantage to Khmer Army Forces. The eight squadrons (troops) in the force structure were generally disposed half in the Phnom Penh area (one per division) and half in the outlying areas. The practice of placing each of the squadrons assigned to the mechanized regiment under the operational control of various military region commanders left the Phnom Penh-based regimental headquarters with no tactical mission, thereby wasting a competent staff organization.

Significant combat actions during the period in which the mechanized squadrons played a major role include: the relief of Oudong-Lovek (May-July 1974), the opening of Route 5 from Pursat to Kompong Chhnang (Nov-Dec 74), and the Wet Season offensive in the Bassac (Sep-Dec 74). The heavy use of these units is graphically demonstrated by the APC combat losses suffered during this period (12 lost, compared to an average of 5 per year from 1971-1973, and 17 requiring evacuation out of country for repair). The heavy use also led to significant maintenance support problems and particularly heavy wear on track and suspension systems. Since the MAP program authorization did not allow for maintenance float vehicles, the result was a steady degradation of the combat power of these units. Out of an authorized strength of 200 M113 type vehicles (including mortar carriers and recovery vehicles), the average on-hand strength was 190, with 165 operational. At the end of December, just prior to the final KC offensive, the on-hand strength was down to 185, with 153 operational.

The approved force structure also called for a tank regiment (Battalion) and a Motorized Regiment, but these units were never operational during the period, except as local security forces for the Armor School at Das Kanchor. This was due to a lack of tanks and trucks necessary for them to perform their primary mission. The Tank Regiment had been equipped with prior - MAP M24 Light Tanks and French AMX-13's; however, by early 1974 these were non-operational due to a lack of spare parts and ammunition. No suitable replacement vehicle was available through MAP nor, for that matter, in the US inventory. The only suitable substitute would have been the M-41 (the M551 being too expensive, complex and unauthorized for MAP programming). The possibility of equipping Khmer units with the M41 or with medium tanks was investigated and rejected due to a combination of political problems, funding constraints, and the lack of long-term supportability in the case of the M41.

[REDACTED] [REDACTED]

Monitoring the status of the squadrons was difficult. EIUI reports were supplemented by weekly reports by the Vinnell Corporation TCN assigned as maintenance advisor to the Armored Brigade.

2. MAP. One problem encountered in attempting to apply MAP procedures in support of Khmer mechanized forces was that, as mentioned above, the program authorization did not allow for a maintenance float. This meant that when vehicles had to be shipped out of country for rebuild, they could not be replaced. As a result, only critically combat-damaged vehicles were retrograded and no rebuild program based on age or wear alone could be supported. Some minor problems were also encountered in trying to establish a US-type system of property accountability; however, this was well on its way to being accomplished by the end of 1974.

3. LEADERSHIP. One of the major strengths of the Khmer Army mechanized forces and one which distinguished them from many other Khmer Army units was the professional competence of the majority of their officers. With very few exceptions, they were well-trained and highly motivated. This professionalism is probably the result of a combination of factors which distinguished officers of this branch from many of their colleagues. An armored force had been part of the Royal Cambodian Army prior to 1970 and was one of its elite elements. The majority of the officers in the pre-1970 force had been trained in France at the Saumur Cavalry School, gaining both professional expertise and esprit de corps. In addition to those officers who were French-trained, US-trained officers were placed in key positions, i.e. Commanding General, Armor Brigade, Inspector for Armor and Cavalry; Commander, Mechanized Regiment, and four of eight squadron commanders. As a result of this background and of continuous supervision and evaluation of unit commanders (resulting in the relief of three of the squadron commanders during the six month period Oct 74 - Mar 75), Khmer mechanized units did not suffer from the leadership failures experienced by many other army units. Unfortunately, the high degree of professionalism and experience in armor-infantry operations of Armor Brigade officers was seldom matched by their infantry colleagues. As a result, mechanized units operating under the operational control of infantry commanders were often less than fully effective as a result of poor coordination and unimaginative tactical employment. Use of the APC's in a stationary overwatch role sacrificed their shock value, while use of the APC's leading the attack with infantry following increased the carriers' vulnerability to RPG fire and resulted in greater combat losses.

This problem was compounded during the KC New Year's Offensive, as many of the more competent infantry battalion and brigade commanders were killed or wounded and were replaced by poorly trained and inexperienced subordinates. In addition, the heavy casualties and lack of replacements for infantry units meant that, even when competent leadership was available, troop strength was inadequate to either properly support the mechanized units or to exploit their successes.

4. KC NEW YEAR'S OFFENSIVE. On 1 January 1975, six of the eight mechanized squadrons were stationed in the greater Phnom Penh defense area, including the four divisional squadrons, one squadron at Kompong Speu, and one at Lovok. The other two squadrons were on Route 5 at Kompong Chhnang and Pursat. The

[REDACTED] [REDACTED]

[REDACTED] [REDACTED]

four divisional squadrons had returned to their division base areas the previous night after participating jointly in a major clearing operation in the Bassac Campaign. The total operational strength of these squadrons was 118 armored vehicles, vica the 150 authorized. Five of these six squadrons were engaged almost immediately - three in the northern sector and two north of Route 4. In major actions in the 7th Division AO and north of Route 4 near Tuol Leap during January, by aggressive and effective use of armor - infantry task forces, link-up was effected with the besieged 7th Division Command Post and the defensive line re-established at Tuol Leap. Attempts to reopen Route 5 between Prek Phnu and Lovek were unsuccessful, however, resulting in the isolation of the squadron at Lovek. An additional squadron (minus one platoon) was shifted by river convoy from Kompong Chhnang to Phnom Penh, once again bringing the number of squadrons in the Phnom Penh perimeter to six. While mechanized forces continued to be used extensively throughout the defense of Phnom Penh, their effectiveness declined during the months of February and March. Not only were new M113's to replace combat losses not available until the last week in March (and then only because of a major MEDTC and CINCPAC effort which located rebuilt diesel-powered M113A1's in Sagami, Japan and by a major reprogramming effort to fund their acquisition), but the out-of-country rebuild program in Taiwan was being phased out, which meant that even rebuildable assets became in effect total losses. During the period 1 Jan-26 Mar (when the first of the M113A1's were delivered in-country) the squadrons had suffered a total of nine M113's completely destroyed and nineteen M113's, one M106 mortar carrier and one XM806 recovery vehicle damaged beyond in-country repair capability. During the same period, only six vehicles could be evacuated for out-of-country rebuild and 16 were returned from that program. The net result was that, by 26 March, the number of M113's potentially available for operations had dropped from 151 to 136, of which 96 were available for Phnom Penh defense. The average operational strength of the squadrons had dropped from 15 to 13 (12 per squadron in Phnom Penh) out of an authorized 21.

The extremely high loss rate during this period was the result of the significant increase in the battlefield density of RPG anti-tank weapons (which accounted for all nine of the totally destroyed vehicles and one of those requiring rebuild), and by the significant increase in enemy use of anti-tank mines (which accounted for 15 of the 19 requiring rebuild).

The expedited delivery of M113A1's which began on 26 March 1975 had, by the 10th of April when deliveries were stopped, alleviated the effective strength situation somewhat. Delays in delivery of ancillary equipment (gun shield kits, intercoms, radios, etc.) reduced the effectiveness of these assets, as only 25 of the 45 delivered could be placed in fully operational status.

5. MOST CRITICAL PROBLEM AREAS. Throughout this period, effectiveness of Khmer mechanized forces was reduced by the problems of inadequate training and/or strength of supported infantry units and lack of understanding of proper employment and support of mechanized units on the part of many infantry commanders. This problem became more critical after 1 January, when the combination of high casualties, increased density of KC anti-tank weapons, and termination of the out-of-country rebuild program combined to produce a rapid deterioration in the

[REDACTED] [REDACTED]

[REDACTED] [REDACTED]

combat effectiveness of the mechanized squadrons.

A second critical problem was the type of equipment with which these units were equipped. While the M113 type vehicles can be highly effective, particularly when gun-shield kits are mounted to protect crew members, their vulnerability to light anti-tank weapons and mines is a significant limitation. The dramatic increase in the battlefield density of such weapons after 1 January 1975 and the lack of effective countermeasures (primarily coordinated suppressive fires and trained infantry) combined to cause a rapid deterioration in the effectiveness of mechanized units.

8. CONCLUSIONS.

- a. Khmer Army mechanized units demonstrated that even light armor forces can make a significant difference in the outcome on the battlefield in the Southeast Asian environment.
  - b. Effective employment of mechanized forces requires close coordination with and adequate training of supported infantry units and their commanders. Lack of this training and coordination reduced the effectiveness of Khmer mechanized forces.
  - c. In spite of the demonstrated effectiveness of the M113 as an assault vehicle in this environment, its high vulnerability to RFG's and anti-tank mines was a serious limitation. Light tanks would probably have been more effective and less vulnerable, had suitable vehicles been available.
  - d. Unless assured of continued out-of-country repair and rebuild support, development of in-country capability must be a high-priority program for early implementation when tracked vehicles are introduced into a MAP-supported country. In the Cambodian case, a shift from Taiwan to CONUS rebuild would have doubled costs and increased turn-around time by approximately two to four months. By the time the final decision was made to close out the Taiwan facility, shipping of rebuild vehicles to CONUS was precluded by both cost and lead-time considerations, resulting in the accumulation of nineteen rebuildable vehicles in-country.
  - e. The effectiveness of Khmer mechanized forces was to a large degree the result of the existence of a highly professional, well-trained officer corps which was already established prior to 1970 and to the effective utilization of US Army Armor School trained officers in key positions.
- [REDACTED] [REDACTED]

ENGINEER OPERATIONS

1. BACKGROUND. The Engineer Staff Officer was the senior logistics officer and therefore, served as Chief of the Supply and Maintenance Branch, Army Division. In his engineer role, he was primarily involved in engineer logistics matters, force structure planning, and other engineer matters within MEDTC. Principal interface with FANK was through BG Long Man, the Commandant et Directeur du Genie (Chief of Engineers), who commanded engineer general support forces and had technical responsibilities vis-a-vis direct support engineer forces. He also served as the technical service logistician to FANK. Principal staff members included two deputies (operations and logistics) and the respective heads of the staff sections.

In addition to the normal logistics and operational responsibilities, DIRGENIE (Direction du Genie) also had contract construction and facilities maintenance responsibilities. These were never viable during the 1974-1975 time frame due to the marginal solvency of FANK.

The engineers were organized and equipped as a pioneer force. The combat support elements had little except hand tools and an occasional bulldozer on loan. The force structure (Incl 1) was never fully MAP-supported and only about one-half the equipment was delivered. The separate companies in the brigades were essentially non-existent. Divisional units were employed almost exclusively as infantry. Engineer units were generally at higher strength than combat units and the Engineer Brigade was at nearly full strength. Engineer equipment was concentrated in the Brigade and at the Engineer Depot. Much of it was either FANK-purchased or provided by prior MAP; all of it was old and difficult to maintain. Bridging assets were completely inadequate--particularly light floating equipage.

2. MAP. Investment - The acquisition of long-lead-time items under MAP is a time-consuming and inflexible process. MAP-CB always suffered from the necessity of constantly reassessing requirements and reprogramming end items. The wholesale cancellation of end items from the FY 74 program (to recoup funds for ammo) proved to be particularly disruptive to engineer units. They were never adequately equipped with dump trucks and light engineer equipment. Parenthetically, this recoupment was only partially successful, as cancellation costs severely reduced the funds ultimately available.

Follow-On Spares - Procedures for the funding of operations and maintenance permit sufficient flexibility, if supply managers are experienced. Higher headquarters permitted considerable latitude in requisitioning, particularly in the area of commercial consumables. Reprogramming from

[REDACTED] [REDACTED]

one RCN to another was easily accomplished. The principal management shortcoming was the lack of a systematic compilation of historical data and subsequent application to budget projections. The response time of the United States supply system can only be deemed marginally adequate, except for those special cases receiving high priorities and intensive management. FANK engineers were gradually learning how to operate their supply system, and, with the invaluable assistance of our Third-Country Nationals, were making slow but steady progress toward establishment of a sound logistics system. They were very slow to make changes even when the need to do so was clearly recognized.

Training - It takes literally years for CONUS MAP training to have a measurable impact. For the near term, short courses and OJT are much better. In the engineers, the CONUS returnees were being effectively used, as most battalion commanders were graduates of the Engineer Officers Advanced Course. Additional training in logistics management was clearly indicated.

3. KHMER LEADERSHIP. By and large, the engineer officer corps was superior to other branches. General Long Man spent much time in the field with his troops. The battalion commanders were well-trained and responsive to mission assignments. The troops worked well even during the afternoons and at night. Excellent examples of such were the construction of a Bailey Bridge on Route 5 in the Fall of 1974 and the airfield damage repair work at Pochentong in March 1975. The overall coordination problems, particularly those involved in obtaining adequate logistical support, were always major difficulties. In the engineer depot, the principal leadership problems were caused by the low pay of troops and the concomitant necessity for the men to work at other part-time jobs in order to survive. While some corruption must have been present (probably in terms of fees for equipment loan or repair), it did not significantly impact on mission accomplishment. As with all Khmer organizations, power was always concentrated at the top with little delegation to subordinates; operations were a one-man show and the resultant partial paralysis was predictable.

4. FUNDING. The successful management of MAP funding requires experience, particularly in coordinating requisitioning cycles with funding cycles. In the case of barrier materials, it was difficult to maintain a satisfactory flow into Cambodia because of stop-start funding, uncertain order and ship times, and a tenuously held LOC. Requisitions had to be submitted as funds became available and not necessarily as requirements dictated. By and large, this uncertainty was prevalent in all high dollar value/or large quantity stock replenishment actions. The other funding problem having major impact was the uncertainty of funding levels. Needed procurements were delayed to the last minute to retain flexibility should later reductions materialize.

[REDACTED] [REDACTED]

[REDACTED] [REDACTED]

5. RELATIONSHIP WITH OTHER AGENCIES. The Khmer engineers had major coordination problems with the Ministry of Public Works as to areas of responsibility and degree of mutual support. There was no mechanism in the US Mission to routinely coordinate USAID-MEDTC response in this area, thus, each case was handled ad hoc. Lack of funds was always an inhibiting factor. Generally, the military engineers adopted a "hands off" policy in areas of Public Works responsibility. This usually meant that National Routes were inadequately maintained because of no response from Public Works and the military ignored the problem unless of major tactical importance.

6. KC NEW YEAR'S OFFENSIVE. The engineer response was largely one of business as usual. The general staff apparently had no conception as to how engineer capabilities might be exploited. No effort was made at the outset to maximize the construction of defensive works and alternate positions, maintain or improve LOC's or construct barriers. Unfortunately, as an economy of force measure, the engineer brigade was tied down with a rear area security mission reaching from the Pochentong perimeter to the Kantauk Ammo Depot. Engineer equipment which might have supported field fortification construction efforts sat idle for lack of fuel or minor maintenance requirements. All direct support engineer units were used as infantry. The closing of the Mekong had little initial impact and only later did the inability to move heavy equipment begin to create difficulties.

7. MOST CRITICAL PROBLEM AREAS.

- a. From the US point of view, the uncertainty as to the level of funding support to be provided was certainly the overriding problem.
  - b. On the Khmer side, the lack of a working staff at EMG severely hampered the effective use of the supporting forces. Given the inability of EMG to coordinate even the combat arms, the situation with respect to other forces was even worse.
  - c. The Khmer engineers were largely immobile due to three factors:
    - (1) Family separations were not tolerated.
    - (2) Engineer equipment could not be physically moved from one enclave to another.
    - (3) Inadequate logistical transport precluded the movement of personnel, supplies, and repair parts to enclaves where they were needed.
- [REDACTED] [REDACTED]

[REDACTED]

8. CONCLUSIONS.

a. Engineer forces should be equipped to meet local needs and in accordance with local usage. Tool sets, US type, remained on shelves in depot pack while units cried for small shovels. Heavy bulldozers bogged down where small or medium dozers could have operated. Light stream crossing equipment was unavailable; hence mobility of infantry was severely reduced during the Wet Season.

b. Support to enclaves requires prepositioned equipment and manpower to overcome lack of mobility. Adequate and continual resupply is vital.

c. US views as to roles and missions are not always shared by others. The direct support companies in the intervention brigades were totally ineffective. Examination of the roles of divisional battalions might have concluded that they should have been in a general support role under the Chief of Engineers. Force structure planning must be continuous, flexible, and reflect local realities.

d. MEDTC staffing was inadequate. An external element with personnel rotating in and out-of-country to gain expertise could have provided valuable backup services, particularly in long-range planning and MAP logistical management. The TCN's were invaluable in logistics operations.

e. Restrictions against advising made the logistical interface a most sensitive area.

[REDACTED]

[REDACTED]



**ENGINEER FORCE STRUCTURE**

COMBAT SUPPORT FORCES

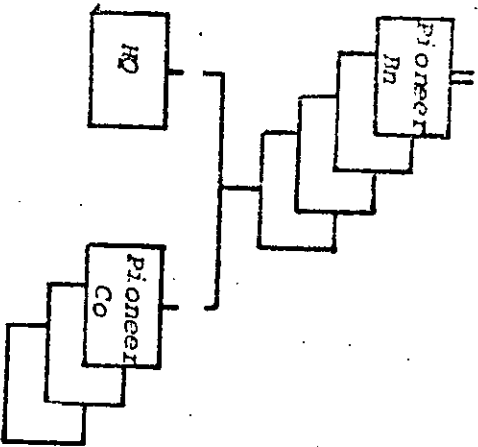

Divisional Units

GENERAL SUPPORT FORCES

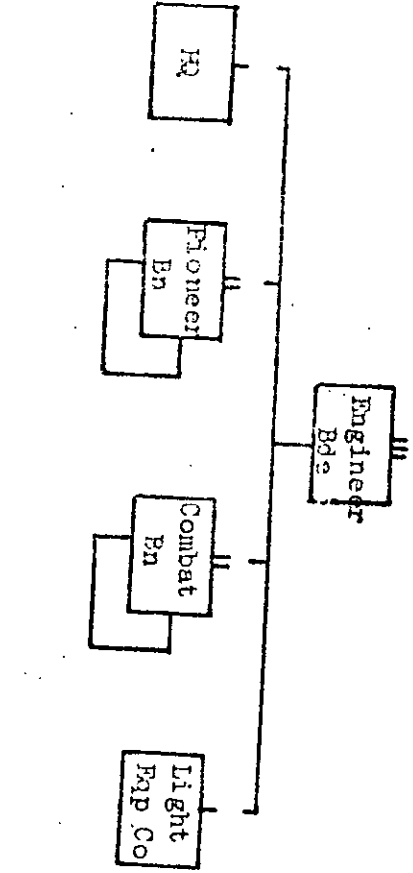

Separate Bdes

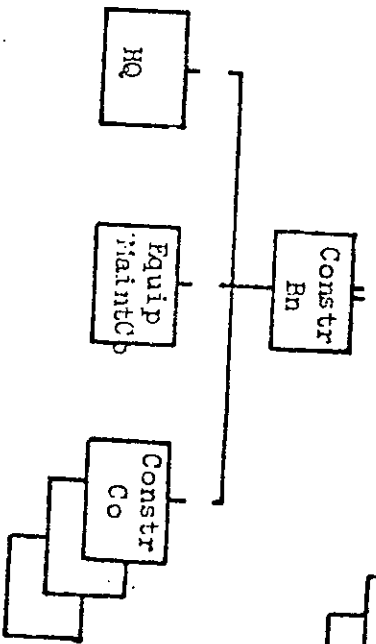
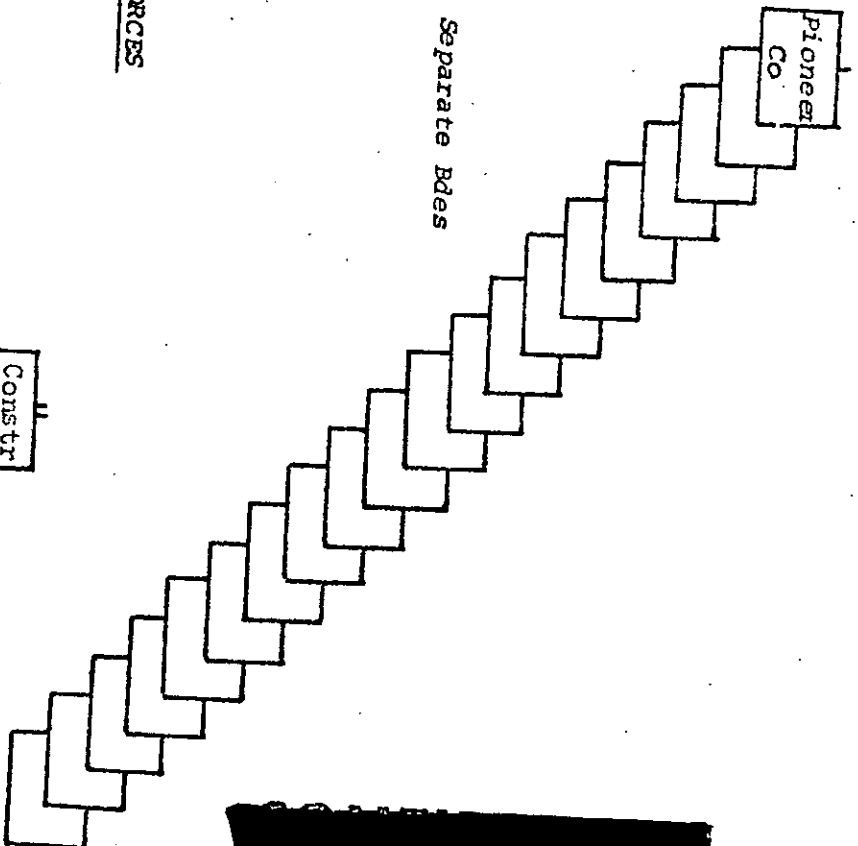

SPECIAL FORCES

1. BACKGROUND. The Khmer Special Forces (KSF) were initially trained in 1971 and 1972 in Thailand by US Special Forces for the purpose of creating and directing partisan operations in enemy-controlled territory. During the early stages of employment, the unit was used for conventional reconnaissance missions and in some cases fought as infantry. There was a lack of understanding in the Khmer General Staff as to the nature of the unit's mission and a reluctance to commit scarce aircraft assets to Special Forces operations. In February of 1974, the organization was recovering from its employment as infantry in Kompong Chan and its use in counter-rocket missions on the Phnom Penh perimeter. As a result of this employment, KSF had lost five detachments, but had no means to replace them and no significant partisan operations had been initiated. The problem of the employment of KSF was complicated by the fact that the unit was usually being given missions that originated at the Presidential Palace. These operations were normally not coordinated with the General Staff until there was an indication of trouble; then it was too late. As a practical matter, the employment of KSF in conventional and Presidential tasks would probably continue, what was required was additional assets to absorb these missions. The solution to the KSF problem was to enlarge the organization to include a Para-Commando Battalion that would handle the infantry missions that KSF received, and a Reconnaissance Battalion to execute the conventional reconnaissance missions. This was accomplished by the Fall of 1974, but it was not possible to equip these new units with weapons and radios because of higher priority infantry requirements. The lack of a training program to replace Special Forces detachments remained unsolved. MEDTC provided a part-time officer to monitor KSF. Since little equipment was provided to this unit, few funds were involved. Although the Para-Commando Battalion was untrained and unarmed and the Reconnaissance Battalion was only partially armed, BG Thach Reng, the commander of KSF, began a partisan operation in November. Some 1,600 villagers living in KC-controlled territory in the Lower Bassac Region opted for the GKR side, but most wanted to be evacuated. Eventually, approximately 100 of these people were armed and returned to the KC-controlled area to act as partisans. KSF prepared for the Dry Season by calling in their deployed detachments to retrain. It was planned to use the trained Special Forces personnel for partisan operations, the reconnaissance element to patrol beyond the enclave perimeter and the Para-Commandos to exploit the information gained.

2. MAP. The initial training phase of the KSF program worked well, and a good unit was created. Unfortunately, no follow-on program or in-country capability was created to replace the combat casualties. As funds became tighter in the Fall of 1974, the MAP system could no longer support KSF in its major requirement to arm and equip its two new battalions. In addition, the austere manning level of MEDTC precluded the appointment of a full-time US monitor. Inability to conduct US in-country training precluded vital instruction in a number of key skills. Thus, the restrictions placed on the MAP system in Cambodia, the limitation on US personnel, the lack of sufficient funding and the inability to train severely hampered assistance to the KSF.

[REDACTED] [REDACTED]

3. KHMER LEADERSHIP. KSF had very few officers who were capable of planning and executing operations. This lack of depth would have limited the capability of this organization if significant partisan operations had been started. Additionally, the Commander, BG Thach Reng, identified with the Presidential coterie and hence was not well-received at the Khmer general staff. This situation deprived KSF of adequate representation at the level where aircraft and operational coordination were available. BG Thach Reng's performance was not adequate in the field of supervision; once his units were committed, he often was unaware of their performance despite ample opportunities to check on them. There was no indication of corruption in KSF; the use of "phantoms" was not indicated, and it is believed that this stemmed from BG Thach Reng's personal integrity. The caliber of leadership within the KSF and the focus on the Presidential office, therefore, prohibited effective employment of the unit. The 1971-72 US training investment in KSF was not justified in terms of end results.

4. FUNDING. KSF, not having established a partisan base or a successful operational capability against the KC, did not warrant enough of a claim on scarce resources to be able to fill its needs. Until January of 1975, the new units in KSF were unarmed and lacking communications equipment. KSF was not funded.

5. KC NEW YEAR'S OFFENSIVE. At the beginning of 1975, KSF had begun a period of retraining, calling in most of their outlying detachments. The KC offensive offered two tactical opportunities for KSF to exploit; operating in the enemy rear along the Lower Mekong, and interdicting the KC lines of communication coming into the Phnom Penh perimeter. Although both of these opportunities were obvious, the KSF leadership did not seize on them, but waited for resources and missions to be thrust upon them. Reluctantly attempting only one interdiction mission, the KSF leadership allowed the most minor obstacle to abort the mission and failed to press for better results. The General Staff accepted this performance, failed to take action for further interdiction missions and gradually drew KSF into an infantry role on the Phnom Penh perimeter. As a result, the KC were able to enjoy a secure rear area and unhampered LOC's throughout their successful 1975 Dry Season Offensive.

6. MOST CRITICAL PROBLEM AREAS. A lack of aggressive leadership, focus on Presidential tasks and an inability to equip added units in enough time to permit training crippled the use of KSF.

7. CONCLUSIONS.

a. The Khmer leadership was not capable of using unconventional forces to organize, plan and execute partisan operations. Such operations were possible in Cambodia.

b. Restrictions placed on US military personnel precluded the Khmer from receiving assistance in mounting effective partisan operations.

[REDACTED] [REDACTED]

PSYCHOLOGICAL WARFARE

1. BACKGROUND. Few areas of contest between the KC and GKR offered as great a potential for GKR success than psychological warfare. The KC were at a distinct disadvantage in that they represented collectivization of farm property in a nation where the peasant traditionally owned his own land; the KC actively pursued an atheistic line in a country that is deeply Buddhist; and the KC could not effectively disassociate themselves from their North Vietnamese mentors, a particularly damaging point in view of the fundamental ethnic hostility between Khmer and Vietnamese. Yet, this enemy weakness was not exploited to any significant degree. The reasons for this failure were: a lack of coordination between the Presidential coterie and EMG in matters concerning psychological operations; a proclivity of the psychological warfare leadership to concentrate on the political indoctrination of the GKR citizen as opposed to offensive psychological operations; a universal lack of aggressiveness on the part of psychological warfare officers and an inability of the Military Assistance Program to deliver adequate amounts of psychological warfare equipment due to higher priority requirements.
2. MAP. The MAP funding level for the Khmer Republic was not sufficient to provide for adequate psychological operations. The necessity to use available funds for lethal munitions precluded the provision of enough equipment for an operational political warfare battalion. The Khmer benefited by attendance at several MAP-supported US psychological warfare courses, but poor personnel assignment procedures resulted in few returning graduates receiving psywar assignments. Personnel limitations held MEDTC to one part-time officer to monitor this area, thus US supervision could not be extensive.
3. KHMER LEADERSHIP. The prime mission of the Khmer political warfare effort was to instill loyalty to Marshal Lon Nol. Little enthusiasm, hence little effort, was directed at active psychological operations against the enemy.
4. FUNDING. See paragraph 2.
5. RELATIONSHIP WITH OTHER US AGENCIES. The USIA representative was precluded from operating in the psychological operations field by his organization's regulations. The Political-Military Section of the Embassy, however, did actively assist the Khmer in this field, and the MEDTC representative worked in close coordination with this section.

[REDACTED] [REDACTED]

6. KC NEW YEAR'S OFFENSIVE. As enemy forces approached the defenses of Phnom Penh, their casualties began to mount and prisoners indicated the increasing use of untrained personnel, which presented an ideal opportunity for the use of "scare propaganda". Unfortunately, the Khmer psychological operations officers were only concerned with presenting a "willingness to negotiate" theme, a line that emphasized the weakness of the GKR. In February, the Director General of Political Warfare finally demonstrated some interest in leaflet operations and requested paper for operations.

7. MOST CRITICAL PROBLEM AREAS. The most serious impediment to successful psychological operations in the GKR was the lack of motivation on the part of Khmer psychological operations officers. The second critical area was the lack of an ability of US personnel to encourage and advise the Khmer. Finally, a lack of funds precluded any substantial assistance in the psychological operations field.

8. CONCLUSIONS.

a. The KC and the undecided Khmer population were vulnerable to psychological exploitation.

b. By placing political indoctrination at a higher priority than psychological operations, the Khmer Political Warfare leadership effectively precluded exploitation of KC weaknesses.

c. If the Khmer had attempted serious psychological operations, and if US personnel had been able to advise and train, psychological warfare efforts could have assisted the overall war effort.

[REDACTED] [REDACTED]

SIGNAL OPERATIONS

1. BACKGROUND. During the period February-December 1974, the MEDTC Signal Officer was required to perform both as a logistics and operations officer. The MAP program pertaining to signal operations during this period involved two basic areas: end item investment (defined lines) and operations and maintenance support (dollar lines). These were further subdivided, the former being comprised of funded deliveries of equipment and FY 75 attrition investment, the latter concerned with communications spare parts, repair and return of radio modules, and repair and return of other C-E (communications-electronics) equipment.

One major program change occurred in October 1974, when funds previously earmarked for vehicular radio equipment were cancelled to enable MAP-CB to purchase additional AN/PRC-25 radio sets and RC-292 antennas, critical at that time to Khmer Army signal operations. While the 38 antennas ordered were delivered in March 1975, no radios were received for issue. Although they had been identified by the ILC (International Logistics Center) as being available, MAP-CB was advised they were being retained in reserve stock for active US Army requirements. Repeated requests by MAP-CB to have these radios released for delivery were unsuccessful, as withdrawal action from reserve stocks was never initiated by the Department of Army.

Reduced funding of overall programs in FY 74 and 75 resulted in limited availability of funds for attrition investment in CE equipment, with the entire FY 74 and 75 attrition investment totalling only 157 AN/PRC-25 radio sets. Combat loss experience from February 1974 through December 1974 remained fairly constant and was consistent with available data commencing in July 1972. Losses during the KC New Year's Offensive in 1975 were far above the average.

<u>ITEM</u>	<u>LOSSES JUL 72-MAR 75</u>	<u>AVG ANNUAL LOSS</u>	<u>LOSSES DEC 74-MAR 75</u>
AN/PRC-25	1,039	346	374
RC-292	62	20	44

The communications system in the Khmer Republic revealed two basic shortcomings:

a. Failure to provide adequate support to outlying echelons of the military organization because of the lack of funding for military region logistics centers.

b. Failure of the Khmer Army to utilize equipment as originally programmed.

These failures were interrelated, with failure in one area tending to amplify the effects of the other. The inability to utilize equipment in accordance with a consistent plan resulted in no single unit of the Khmer Army possessing its full complement of authorized equipment and, in many instances, those units possessing some equipment lacking the means to maintain it.

[REDACTED] [REDACTED]

2. MAP. Leverage provided by MAP in dealing with the Khmer Signal organization was never a problem. The Khmer were willing to act upon shortcomings noted by EIUI inspections. The major stumbling block was at the highest echelon of the Khmer logistics chain, where decisions on utilization were made by the J-4 and passed down to the signal technical service. In most cases, decisions were made by the J-4 without regard for J-3 considerations.

Within the framework of an army organized on the basis of French influence, the Khmer Signal logistics organization adapted itself to the requirements of the US logistics system. The Khmer Army Signal Corps was extremely fragmented, detracting from efficient signal logistics and operations. Reorganization was recommended by MEDTC but was not accomplished.

The MAP is not a good means to support a communications effort of a country at war. Rules governing programs and lead times are neither realistic nor responsive to the type of fluid situation that was encountered in the Khmer Republic. Although investment dollars for CE were never plentiful, funds were available for support of dollar line requirements. Since the Khmer Army Signal Depot was relatively self-sufficient in maintaining its equipment, OSM funding support was significant in maintaining equipment availability.

3. KHMER LEADERSHIP. The leadership provided throughout the Khmer Signal Corps can be categorized as marginally effective, at best. The fragmentation of the Khmer Army Signal operations, training, and logistics under different principal staff sections was a major factor in the inability to control and coordinate signal matters.

The J-6, principal staff officer for signal operations, was ineffective in controlling operations within the realm of the signal corps, as all subordinate signal elements were under the control of other principal staff elements. The Signal Brigade, poorly organized to suit the needs of the Khmer Army, was placed under the operational control of the J-3, as were all other combat and combat support organizations. The Director of Communications (DCT) was under the direct control of the J-4, while the Signal School was under the control of the Director General for Instruction (DGI). Decisions on equipment utilization were made without regard to the requirements known to the J-6.

Attempts to prod key personnel to visit units were frequently met with the excuse that there was no means of transportation available. While this is somewhat supportable with respect to the outlying areas, there was no validity for this contention with respect to the many units in close proximity to the Phnom Penh perimeter. The resultant lack of first-hand knowledge of signal unit personnel and equipment status was detrimental to signal logistics operations. Lacking the up-to-date status, the DCT was not able to make a valid determination as to the level of required maintenance and supply support to units scattered throughout the country and around the Phnom Penh perimeter.

The standard method for insuring accountability of equipment within units was basically sound. Each unit maintained an equipment register card to the Stock Control Section of the DCT, listing all end items of equipment chargeable

[REDACTED] [REDACTED]

[REDACTED] [REDACTED]

to the unit. Additionally, a stock record card was compiled for all end items, showing the date of receipt (title transfer) into the Cambodia MAP, and the unit to which equipment was subsequently issued. Effectively, this is where accountability ended. Subsequent adjustments to inventory were made if and when reports were received at DCT through the logistics chain. The two types of reports impacting on unit equipment status records were:

- a. Monthly combat loss reports.
- b. Reports of equipment transfers between units.

In the case of the monthly combat loss report, the track of equipment losses was relatively easy to follow by both FANK and MEDTC, as reports were submitted to the J-4 and subsequently to the Minister of National Defense, who was the final approving authority for combat losses. The drawback to this system was that the entire cycle, from initial report by units to approval by the Minister of National Defense, took approximately three months. In the case of equipment transfers between units, all accountability virtually ceased to exist. It was common practice throughout FANK to transfer equipment among units with no regard for accountability. When this occurred, it was rare to find units submitting follow-up reports on equipment gains and losses. Although the DCT did make repeated efforts to have units submit reports, no follow-up was pursued through command channels, and J-4 only gave the matter lip service, destroying the validity of central stock records. The result was that DCT was unable to accurately forecast unit equipment needs versus TOE authorizations. More significantly, it was unable to accurately determine spare parts requirements. A prime example of this occurred in the provision of dry cell batteries for tactical radio equipment. The annual dry cell battery requirement for MAP-CB was approximately \$1.7 million, of which \$1.25 million was for PRC-25 batteries. Without accurate knowledge of unit equipment density lists, DCT was unable to establish unit monthly battery requirements. Lacking this ability, it was necessary for MEDTC to establish a monthly country-wide supply rate for dry batteries based on best estimates available considering MAP equipment program levels, less known combat losses.

Third country and CONUS training of Khmer Army personnel can be characterized as having been successful, although in the later stages the Signal Corps was having difficulty filling CONUS training slots due to the lack of English language training. Those officers returning from CONUS training were well-motivated and obviously favorably influenced by what they saw and learned in the US.

Khmer Air Force (KAF) signal maintenance was divided into two areas, avionics and ground C-E equipment. The avionics maintenance facility was a well-organized operation, MAP-supported, and supervised by a Third Country National (TCN). The ground maintenance shop was created arbitrarily by KAF, not MAP-supported and therefore ill-equipped; it never received the proper attention of the KAF general staff.

The signal technical service is considered to have been well-organized and most responsive to the needs of the Army on a country-wide basis.

[REDACTED] [REDACTED]



[REDACTED] [REDACTED]

4. RELATIONSHIP WITH OTHER US AGENCIES. The Federal Electric Corporation received a contract on 1 February 1971 to install, operate and maintain in-count telephone, teletype and secure voice communications. The manning level to provide operational and technical support was one American and 17 Third Country Nationals (TCN). Various local nationals were employed for site maintenance, buker construction and repair, secretarial services and drivers. No provisions were made for site security. FEC maintained four sites located at Pochentong Airbase, the American Embassy, EMG Compound, and the Ministry of Interior Compound. The principal equipment items were AN/TRC-129 troposphere scatter radio systems between Phnom Penh and Long Binh, RVN. FEC in late November 1974 also contracted to operate the TACAN site at Pochentong Airfield.

The sites were interconnected by radio and multi-pair cable, and provided communication channels for all the US mission elements and selected FANK high priority requirements in support of combat operations. These sites were manned 24 hours a day. The eighteen-man FEC manning level was considered to be the minimum adequate to provide twenty-four hour coverage without degradation of communications. The manning level could not be increased due to the Congressional restrictions on American and TCNs serving MEDTC and the US Embassy. MEDTC provided, and was the office for, coordination for all local/long haul administrative and contingency communications in support of the US mission. FEC proved to be very flexible and cooperative in meeting the requirements of the mission until combat became intense in the Phnom Penh perimeter.

5. KC NEW YEAR'S OFFENSIVE. The cooperation of the FEC supervisors deteriorated during the KC Dry Season Offensive. In March, both the 50-pair cable and the 100-pair cable were partially severed in several places by shrapnel from rocket attacks. The FEC supervisor refused to have the cuts repaired until a twenty-four hour period passed without rocket fire. After a lack of rocket fire for three days in the vicinity of the cuts, and only after much pressure was exerted by the MEDTC Signal Officer, did cable repairs commence.

As with all other MAP activities, funding for signal equipment and associated items during the KC offensive was difficult. This was due to the lack of sufficient funds for FY 75 ammunition requirements and, while it did impact to a degree on replacement capability, it was not a critical factor since the Khmer signal organization was capable of meeting requirements within existing resources, primarily due to their very effective maintenance capability.

6. MOST CRITICAL PROBLEM AREAS. The fragmentation of the Khmer Signal operations, training and logistics was a major area of concern, as well as the lack of coordination between principal J-staff personnel to insure proper utilization of available resources on a national level.

7. CONCLUSIONS.

a. The Khmer Signal organization was not efficient in the management of equipment or support facilities.

[REDACTED] [REDACTED]

[REDACTED] [REDACTED]

b. Restrictions placed upon the efforts of MESTC communications personnel hampered efforts to resolve internal Khmer signal organizational problems.

c. A general lack of Khmer leadership resulted in a failure to exploit available communications facilities.

d. The overall signal mission, while inefficiently managed, was relatively successful.

[REDACTED]

[REDACTED]

ORDNANCE MAINTENANCE

1. BACKGROUND. Maintenance of ordnance materiel, to include repair parts support, was the responsibility of the Director of Materiel (DIRMAT), FANK. Equipment supported included all M-series trucks, individual and crew-served weapons, artillery pieces, armored vehicles and materiel handling equipment. Maintenance and repair parts support was provided through Direct Support Units (DSU) located in each division, military region and other major organizations with back-up provided by one depot located in Phnom Penh. The DSUs were poorly equipped and the facilities were rudimentary. Operations were limited to sub-assembly replacement, and periodic replacements of a few engines or other major assemblies. The depot in Phnom Penh was well-equipped and adequately staffed; however, prior to 1 October 1974, operations were poorly supervised and the physical plant was inadequate. Subsequent actions led to improvement in both areas. The FY 74 budget provided the required funds for repair parts; FY 75 funding also appeared adequate. Officers trained in COMUS facilities, coupled with technicians trained in Thailand, provided a solid core of skilled personnel. However, these individuals were often misassigned upon returning from training sites. Training also was provided in-country via MEDTC contract by third country nationals employed by the Vinnell Corporation.

There were two major problem areas. First, very few assemblies and subassemblies were repaired. When an assembly or subassembly failed, it was generally replaced by a new like item rather than being evacuated and repaired. Second, the workload at the depot maintenance facility exceeded its capability. This situation was exacerbated by poor morale in the support units, which was caused primarily by low pay and insufficient rice allotments. Since the shops operated only six hours per day, most soldiers secured outside employment in order to augment their paltry government salary. In order to alleviate the poor level of maintenance throughout the republic, two major actions were taken. The visit and subsequent report of the GAO team in the Fall of 1974 was used as a lever to induce DIRMAT to establish a Direct Exchange Program for subassemblies and assemblies as a means of providing more control over MAP-provided repair parts. This program went into effect on 22 January and within one month proved to be a feasible solution for approximately 75% of FANK's repair parts problems. To support the DX program and help alleviate the lack of in-country capability, coordination was effected with MACTHAI Support Group at Smae San to provide repair and return backup service to FANK for fuel and electrical subassemblies, engines and power train subassemblies. Support Group also provided rebuild of clutch discs.

[REDACTED] [REDACTED]

recap of tires and was preparing to rebuild batteries through local contracts. The deadline rate for trucks awaiting parts was significantly reduced during the month of February, and by the end of February the shelves at the DX facility contained ample repair parts in all but a very few lines.

2. MAP. Restricted from advising, MEDTC officers could not impart their maintenance expertise to the Khmer. To be assigned the job of supervising the use of US-provided equipment and having to stand by and watch that equipment abused is extremely frustrating from a personal standpoint and grossly inefficient with respect to MAP-funded equipment. The only means by which MEDTC could influence the procedures used by FANK was by threatening to cut off all aid, not a credible threat, and through the contractor-provided technical assistance team. The third country nationals provided by the Vinnell Corporation were an invaluable aid in influencing logistic operations. However, as with most valuable resources, they were far too few, also being limited by a manpower ceiling.

3. KHMER LEADERSHIP. For the most part leadership in DIRMAT was adequate. Rumors of graft and corruption floated continuously, but no concrete evidence was produced. Officers generally were capable of performing their mission and some performed extremely well. The commander of the depot in Phnom Penh was an example of a highly qualified, aggressive officer. He had been assigned on 1 October 1974. During the month of March of 1975 a feeling of antagonism toward him surfaced among his personnel. He had been driving them hard since the offensive started on 1 January, and, as FANK successes became less frequent and the ration of rice was steadily reduced, they showed their resentment by making threats on his life and refusing to work. This is a typical example of the poor discipline which permeated the ranks of FANK. Attempts to push for greater production backfired in increased absenteeism.

4. FUNDING. Since a much greater emphasis was placed on repair rather than replacement during FY75, reprogramming action would have been necessary to move funds from repair parts lines to out-of-country repair lines if the FY had been completed. However, this emphasis had already generated sufficient excess funds to allow release of \$275K, about 20%, for other purposes, from the repair parts lines. Congressional inaction caused a problem in the funding of repair parts for weapons; however, reprogramming action alleviated the problem for the duration of the program. The responsiveness of the International Logistic Center's supply system was adequate only when priority G2 was used. Requisitions of lower priority resulted in long order and shipping times ranging from a few months to as much as eighteen months.

[REDACTED] [REDACTED]

[REDACTED] [REDACTED]

5. RELATIONSHIP WITH OTHER AGENCIES. Little coordination with other US agencies in-country was required in maintenance operations. Some actions involved coordination with DAO, but no problems were encountered.

6. KC NEW YEAR'S OFFENSIVE. As the KC offensive got underway, DIRMAT responded with extra effort to repair or replace damaged equipment. DIRMAT was able to provide adequate support as long as repair parts were available. When the Mekong Riverline of communication was closed, a system was developed within MEDTC to insure a continuing, if diminished, flow of repair parts via air. DIRMAT continued to provide adequate support in spite of manpower losses to combat units until the morale of personnel ebbed, due primarily to the shortage of rice, but exacerbated by having worked extra hours for more than two months and seeing little success from FANK forces.

7. MOST CRITICAL PROBLEM AREAS.

a. Physical Plant. Due to short lead time response and an austere funding environment, MEDTC was not able to include requirements for physical plant improvements in the MAP. Since the Khmer Government was not able to provide funds for this purpose, maintenance facilities were universally inadequate. At the time of the collapse of the Khmer Republic, DIRMAT was in the process of relocating a general support maintenance facility from Lovek to Samrong, near Pochentong AB. The equipment was evacuated from Lovek and arrangements made for utilization of a railroad maintenance building which was quite satisfactory. However, there were no funds available to provide electrical power, build partitions or procure cement for the bases upon which the machines would be mounted.

b. Manpower. There was a dearth of manpower identified for maintenance operations, especially in the divisions and military regions. The number of mechanics found at one of these facilities was normally between six and twelve, with only two or three being small arms repairmen. The main depot usually had 120 men present for duty with skill distribution as follows: 60 automotive mechanics, 20 small arms repairmen, 15 artillery repairmen and approximately 25 supply and clerical personnel. The depot work force provided more than two-thirds of the in-country maintenance capability.

c. Lack of Advisors. The restriction on providing logistical advice to FANK by MEDTC was extremely counter-productive. It would certainly appear that the spirit of the legislation would not have been violated had advice been permitted between US and FANK logistics operatives. Audit reports repeatedly reflected the inadequate control of repair parts and poor maintenance practices of FANK, but without being allowed to advise, little could be done to influence those operations.

[REDACTED] [REDACTED]

[REDACTED] [REDACTED]

8. CONCLUSIONS.

a. Providing military assistance without logistical advisors is not cost-effective.

b. Use of contractor-provided logistical technicians to train and augment US military personnel is viable.

c. The international logistic supply system is not adequately responsive to supporting an active conflict.

d. Physical plant programming lead time is too long to be responsive in supporting an active conflict.

[REDACTED] [REDACTED]

SUPPLY OPERATIONS

1. BACKGROUND. Supply operations for the Khmer Armed Forces were based upon activities of two separate but coordinated organizations designed to receive, title transfer and manage all military supplies provided by MAP-CB. Supplies were received in-country and title transferred to the Khmer Armed Forces under the auspices of the Foreign Assistance Office (FAO). The FAO operated directly under the Khmer Minister of Defense. The responsibilities of FAO were to receive all MAP supplies, execute the title transfer and insure delivery to the proper recipients within the Khmer Armed Forces. Further, the FAO was responsible to initiate requisitions for all follow-on support items required in support of combat operations. Additionally, FAO was responsible to manage fund balances for all Record Control Number (RCN) accounts established for dollar line programs supporting operations of the Khmer Armed Forces. The FAO operated principally in three locations. The central offices and main warehouse were located in Phnom Penh. Subsidiary offices and receiving ports were located at Kompong Som and Battambang.

The Director General Logistics (DGL) for the Khmer Armed Forces, headed by the Assistant Chief of Staff for Logistics, managed all supply support for the Khmer Armed Forces. Acting as the overall manager, this office supervised the functions of each of the technical services, which were established as commodity managers of all supplies provided through the military assistance program. Responsibility for technical services was broken down as follows: DIRMATERIEL--ordnance-type items such as vehicles and weapons; DIRGENIE--engineer materiel and services; DIRTRANSMISSIONS--signal services and communication equipment; DIRTRANSPORT--military ground transportation; DIRMUNITIONS--all munitions, both ground and air delivered; DIRSANTE--health and medical services and supply; DIRINTENDANCE--military food supplies, office equipment, personal clothing and equipment; DIRESSANCE--bulk ground fuels and packaged POL products. The Khmer Air Force managed air transportation and the Khmer Navy managed all water transportation.

All logistical staff officers within MEDTC were assigned functional responsibilities to work with the particular technical service as well as with the staff elements within DGL to effect the logistical operations necessary to support the Khmer Armed Forces. The Supply and Services Branch, Army Division was the staff element that had the primary responsibility to work with and manage the operations of FAO and its functional support of DGL. It was staffed with one officer and two NCO's, all qualified supply specialists. Principal responsibilities were: to verify the RCN fund balances on a weekly basis, insure proper procedures were utilized in initiating all requisitions

[REDACTED] [REDACTED]

[REDACTED]

against the CONUS supply system, manage the active open requisition accounts and verify that all MAP-CB supplies received through the FAO were properly title transferred and transshipped to the recipient services. In addition, the supply section conducted periodic inspections (EIWI) to verify the operations of the Foreign Assistance Office. The supply section also worked directly with the staff elements of DGL concerning supply problems related to incoming MAP supplies, and specifically monitored the operations of the Intendance Service plus the weapons and major item accountability system of the Materiel Service. The supply section actively participated in field EIWI. Particularly, it monitored the inspections made by the FANK weapons committee a team established to coordinate the condition and distribution of all weapons within the Khmer Armed Forces.

2. MAP. General Supply Support to the Khmer Armed Forces amounted to only 6 percent of the total MAP-CB budget, or approximately \$17.5 million. A major portion of this money was utilized in obtaining general supplies for follow-on support of the major equipment provided to the Khmer Republic during the period 1970-1974. Since MAP-CB funding was extremely limited, very little programming of major investment items was done during the last half of FY 74 and in all of FY 75. The major effort was to provide the necessary spares and repair parts to keep the equipment already delivered operating. All major equipment delivered to the Khmer Republic suffered from over-use, lack of care and poor maintenance. This increased the requirement for resupply of many repair parts and major subassemblies to repair the equipment. An effective direct exchange system was established to expedite the resupply of high-usage repair parts and subassemblies and, in turn, materially assisted in maintaining an acceptable availability of vehicles for logistical and tactical support operations. This program is discussed in detail in Appendix 8, this Annex. Critical combat items, such as the M113 armored personnel carriers and artillery weapons, were managed by exception and all resupply activities supporting these items were closely monitored by MEDTC logistical staff officers. In general, the MAP-CB supply system was flexible enough to support the requirements of the Khmer Armed Forces, but the limited funds made continuous alteration and supplies had to be reallocated to meet required continuous urgent tactical requirements. This caused undue duress within the supply pipeline, because the CONUS supply system was always 60 to 90 days behind in normal requisition reaction time.

The supply support provided FANK by its technical services was based upon a rigid and complex system dotted with requirements for favors and gratuities. The process of obtaining resupply of a general article required the customer passing the requisition through his logistical support unit and then through the appropriate tech service stock control office to obtain a release of the desired item. Each step in the system provided an opportunity for "kick-back" or gratuities. Cooperation between the services was largely non-existent. The G-4, FANK, technically had the ability to effect transfer of supplies from one service to another, or from one major unit within a service to another. Any management efforts made in this area by the G-4 or his staff were largely ignored.

[REDACTED]



[REDACTED] [REDACTED]

Equipment accountability within FANK was ineffective and rudimentary. Property books were established; however responsible or accountable officers were not appointed. The Materiel Service had a duplicate copy of the property books of Army units. Maintenance of these property books was dependent upon unit input indicating any changes. Since commanders were not responsible or accountable for their property, property book updates were never enforced and total loss of accountability resulted. Attachment and detachment of units from one major organization to another often resulted in crew-served weapons, tactical communications equipment and other vital equipment being withdrawn from the units prior to their transfer. With the exception of artillery, weapons accountability suffered from the same debility. FANK had acquired numerous weapons from a series of sources and Military Assistance Programs. The initial source was French MAP, which included some US WW II weaponry. An earlier US MAP program, from 1955 to 1964, provided weapons for the 30,000-man Khmer Army. From 1964 to 1970, considerable weaponry was provided by China and Russia. Since 1970, US MAP has provided weapons, including foreign manufacture, for the Khmer Armed Forces which rapidly expanded to approximately 253,000 troops. Individuals and units of FANK also purchased a number of US weapons from RVN units that came into Cambodia during 1971-1972. Many weapons were not operable due to the lack of parts, ammunition, or combat damage. The number of weapons damaged in combat was usually high because of misuse and poor maintenance and reporting of combat losses was very poor.

The supply of clothing and equipment for the Khmer soldier was inadequate. For 1974-1975, Service Intendance had established an annual budget of 2.1 billion riel to be provided by the Khmer Government and augmented by an annual average military assistance budget of \$1.53 million. The monies provided by the Khmer Government were to be used to procure locally the annual requirements of uniforms and individual equipment. However, in early 1974, the Khmer Republic lost about 50 percent of its capability to process cotton. As a result, the \$1.53 million programmed to support all types of clothing and equipment had to be utilized to procure basic necessities, i.e., web gear, ponchos, poncho liners, uniforms, and boots. In May 1974, MAP-CB was authorized \$500,000 in FA Section 506 drawdown funds to procure additional clothing items. These funds were used to purchase ponchos, poncho liners, uniforms, and boots. During this same period, a large quantity of combat serviceable clothing was located in RVN and Japan. MEDTC was able to obtain more than 125,000 sets of serviceable fatigues for FANK from these sources. Meanwhile, Service Intendance had made arrangements with some local manufacturers to obtain advancements of uniforms against the accepted but unapproved budget. During the last half of 1974, FANK received over 300,000 uniforms in this manner. Towards the end of 1974, inflation had driven the price of the local uniforms to almost three times the initial delivery price. The Defense Ministry had made only token payments for the uniforms already advanced and,

[REDACTED] [REDACTED]

[REDACTED] [REDACTED]

as a result, the local suppliers stopped all deliveries. However, including the combat serviceable clothing from RVN and Japan, FANK had received sufficient uniforms to issue at least two sets to each soldier. In spite of this fact, EIUI's continued to report many units not having adequate uniforms for the following reasons: many uniforms were sold by logistical activities after receiving the issues from Intendance; favoritism in issuing uniforms to units that did not need them; individual soldiers sold their uniforms to buy food for their families; commanders hoarded uniforms and offered them as tokens for good combat performance; the Commander-in-Chief, FANK, pushed recruiting by ordering two uniforms issued to each new recruit; and all personnel strength figures were known to be inflated which resulted in over-issues to many units.

3. KHMER LEADERSHIP. The quality of leadership among the logistical staffs and technical services was adequate. Many of the officers were well educated in military schools both in France and the US and they understood the US Army supply system. However, the rigidity and inflexibility of logistic operations inhibited many potentially excellent staff officers. The entire logistics structure operated on a 5-day week and was rarely willing to provide support outside of normal working hours. There was very little initiative to seek out the requirements of combat units. Logistics units were also maintained at 100 percent strength, even when combat unit foxhole strength was below forty percent.

4. FUNDING. Many excess items were obtained from such sources as closure of US bases, other MAP programs and Vietnam residue, augmented by off-shore procurement. Over \$110,000 in weapons and ordnance materiel was obtained out of Takhli AFB in August 1974 upon its closure. Weapons and other critical items such as boots and blankets were obtained from Laos excess at 1/3 original purchase price, at a savings estimated at \$620,000. The combat serviceable uniforms from RVN and Japan provided an estimated \$818,000 worth of clothing at the expense of only PCH&T. Off-shore procurements were programmed and executed for 70,000 ponchos at an estimated savings of \$418,000. Combat boots and uniforms were programmed for OSP that would have provided a savings of \$291,000. Each of these programs enabled MAP-CB to stretch its original budget for clothing and equipment to support the requirements of the FANK intervention units.

5. RELATIONSHIP WITH OTHER US AGENCIES. The logistical staff officers of MEDTC worked closely with members of the DAC of the American Embassy who provided excellent information concerning unit status. This information, in conjunction with EIUI's and other inspections, enabled logistical managers to better respond to the needs of FANK. MEDEC reported the delivery and cancellation of all FANK major items of equipment on a monthly basis to DAC.

[REDACTED] [REDACTED]

[REDACTED] [REDACTED]

6. KC NEW YEAR'S OFFENSIVE. Supply operations were drastically changed in reaction to the KC New Year's Offensive. The key factor was the closing of the Mekong River as the main supply route. As a result, all subsequent resupply into the Khmer Republic was air-delivered. General cargo resupply sorties only averaged two per day, or 120 tons of cargo per month and MAP-CB had to operate on about 1/3 the total monthly resupply that had been available when the Mekong was open. A team of two officers and one NCO operating in the Samae San - Sattahip - U-Tapao AFB complex assisted in assuring this limited capability was well utilized by screening all incoming shipments for MAP-CB. Through daily communications with the M&TC logistical managers, they were able to identify and select all supplies that were transhipped into country.

Operations of the aerial port at Phnom Penh were increased significantly due to the airlift. The FAC, therefore, had to make many adjustments in personnel and equipment to support the unloading and transshipping of materiel. The biggest problem encountered was provision of materiel handling equipment. Repair parts for maintenance of forklifts was marginal. As a result, US assets had to be brought into country in order to assure adequate support of the operation.

7. MOST CRITICAL PROBLEM AREAS.

a. Lack of Cooperation. Cooperation between services was very poor in executing logistical support for combat operations. As a result, logistical support for such operations was always slow and unresponsive.

b. Centralized Supply Control. The basic control of all supplies rested with the Technical Services located in Phnom Penh. As a result, units outside of Phnom Penh rarely received timely and adequate resupply support. Supply point distribution required all units to travel to the supply sources and follow complex and rigid procedures to obtain the necessary supplies.

c. Apathy on the Part of the Technical Services. The typical work schedule of the technical services and logistical staffs working in Defense Nationale was from 0900 - 1400, five days a week.

d. Weapons Accountability. Accountability of weapons was a significant and never-ending problem for FANK.

e. Budget. The logistical budget, both the US MAP program and that of the Khmer government, was inadequate.

[REDACTED] [REDACTED]

[REDACTED] [REDACTED]

8. CONCLUSIONS.

a. The reduced budget of both MAP and the Khmer government adversely affected the logistical operations of the Khmer Armed Forces.

b. The number of logistical managers available in MEDTC was too few to properly execute the missions assigned. The amount and type of assistance which was legally authorized to be given by logistical staff officers to their Khmer counterparts limited their effectiveness.

c. The Assistant Chief of Staff Logistics, FANK, and his staff did not have enough power and support from the FANK General Staff and major service commanders to properly accomplish their job.

d. The functions and organization of the Foreign Assistance Office, Khmer Republic were well-planned and executed. The FAO was well-staffed with excellent officers who executed their responsibilities in an outstanding manner.

[REDACTED] [REDACTED]

SECURITY ASSISTANCE PLANNING AND PROGRAMMING

1. BACKGROUND. Security Assistance planning within the Army Division of MEDTC was part of the Department of Defense Planning, Programming, and Budget System (PPES), specifically tied to the Free World Forces portions of the Joint Security Objectives Plan (JSOP) and the Program Objectives Memorandum (POM). From February through June of 1974, this planning dealt primarily with the completion of equipment delivery for the divisional bases for the four FANK infantry divisions and the addition of new artillery units to the force structure.

In July 1974, complete revision of the FY 76-80 POM was required, based on revised budgetary guideline figures and the revised planning assumption that a peace settlement would be achieved some time in FY 76. Further revision of the Cambodia portion of the FY 76-80 POM was required in February 1975, again in response to revised guidelines and assumptions. At the same time, two versions of the FY 77 POM submission were required based on two sets of guideline figures and assumptions. These actions had to be accomplished at the height of the KC Dry Season Offensive when an austere staffed MEDTC was hard-pressed to divert the manpower and time required.

This same turbulence was a major characteristic of the MAP-CB programming effort. During this period, forty-two separate program change actions were submitted involving the Army portion of the FY 74 and 75 programs. These program changes are indicative of the particular problems faced by MEDTC in its attempts to support Khmer combat forces using MAP procedures. Twenty-one of the changes were required to maintain adequate funding for items critically needed for the maintenance of Khmer combat capability under conditions of constrained and incremental funding. Nine were required due to changes in the tactical situation. During this same period, MEDTC underwent a major reorganization in an attempt to maximize the effectiveness of limited personnel assets in rapidly changing conditions. With the creation of separate service divisions, the planning and programming functions were decentralized, causing some minor difficulties in terms of coordination and creating some duplication of effort.

2. MAP. The standard security assistance planning and programming procedures were unsuitable for the situation in the Khmer Republic. While higher echelons, particularly CINCPAC and DSAA, were generally very responsive to short-fuse changes in requirements and great efforts were made to expedite programming and supply actions when required, the MAP-CB experience bore very little resemblance to the normal program as laid out in the Military Assistance and Sales Manual (MASM). Exception to policy became the rule with regard to lead times, commercial-type items, MASM coded NN items, etc. Out-year programs took on an air of unreality as it became evident that by the time they were implemented the assumptions as to level

[REDACTED] [REDACTED]

of conflict, level of funding, etc., would have been overcome by events. During the period Feb 74-Jan 75 in particular, basic changes in Foreign Assistance legislation, constrained and incremental funding, and changes in MASL costs and lead times, made program management a matter of reaction rather than an orderly time-phased action.

A second problem with applying MAP procedures in the Khmer Republic was the very nature of MEDTC. Restrictions on manpower levels and the legal restriction against MEDTC's advising or training the Khmers meant that coordinated and close management of the program was virtually impossible. End Item Utilization Inspections (EIUI) were often frustrated due to the combat situation, and MEDTC was almost totally dependent for information on the embryonic and largely ineffective Khmer logistical reporting system. While the use of contract advisory personnel, third country nationals (TCNs), alleviated this problem in some areas, this effort was also limited by Congressional restrictions as to the number of TCNs that could be hired by the US Government. While attempts were made to develop logistic and financial management skills through the MAP training program, the combat situation dictated that heavy emphasis be placed on training in combat-related skills. As a result, MEDTC and TCN personnel could count on little assistance from the Khmer in the management of MAP assets.

A third problem associated with application of MAP procedures in the MAP-CB environment was that of communications with, and information requirements received from, higher headquarters. Part of this problem was a function of geographic location, there being only a two-hour overlap between MEDTC and CINCPAC normal working hours and no overlap at all between MEDTC and CONUS agencies. Rapid telephonic coordination of requirements involving these agencies was therefore extremely difficult. Most programming actions had to be accomplished by message since one way mail delay times ranged from five to fourteen days. Management documents received by mail from CINCPAC or Mildeps were often outdated and therefore of little use by the time they were received.

MAP-CB management was further hindered by the short-tour length and in-country headspace restrictions which reduced personnel overlap to a bare minimum and made maintenance of continuity extremely difficult. Basically, a programmer never managed the FY program he had designed nor even that of his predecessor with whom he might have had a brief overlap. It was therefore impossible to follow the rationale on which program decisions had been made, particularly when a rapidly changing tactical situation may have rendered that rationale invalid in the meantime. The problem of maintaining continuity in this critical area could have been alleviated somewhat by performing the programming function outside Cambodia, i.e. at the MEDTC rear element in Thailand. This recommendation was incorporated in the Winter 1974 MEDTC study for revision of the Joint Table of Distribution (JTD). Not only would this solution have allowed for more overlap in programmer assignment (there being no personnel limitation on MEDTC Rear) but it would also have allowed at least two in-country spaces (one materiel and one training programmer) to be used for meeting other critical requirements. Under the existing circumstances, programmers were required to double as special projects officers, EIUI inspectors, and the like, reducing their effectiveness in both primary and additional duty areas.

[REDACTED] [REDACTED]

3. KHMER LEADERSHIP. Khmer leadership played little or no role in Security Assistance Planning during this period. Security classification of planning and programming information, and lack of training and experience of Khmer officers in this type of planning meant that this was entirely a US (MEDTC) effort.

4. FUNDING. The above mentioned problems in trying to apply MAP procedures in a combat situation were exacerbated during FY74 and FY75 by the fact that throughout both years, the program was funded by Continuing Resolution Authority (CRA) at a constrained level well below MEDTC-estimated requirements and by a combination of new obligation authority (NOA) and Section 506 drawdown. Under CRA incremental funding, first priority during each funding period had to be given to essential follow-on support items and ammunition, resulting in delaying the initiation of procurement of new investment and attrition replacement items until late in the fiscal year, with resultant delays in delivery. In FY75, the combination of CRA incremental funding, mid-year lowering of the program ceiling from \$362.5 million to \$275 million (including \$75 million in Section 506 drawdown authority) and the retroactive charging of PCH&T costs against the program ceiling resulted in the dropping of several critical items such as M60 and .30 cal machineguns from the program due to exhaustion of NOA funds and ineligibility of these items for Section 506 funding.

A further problem of MAP-CB funding was the series of price increases, accounting errors, and late billings with which the program was charged during FY 75, which included over a million dollars worth of late billings for POL products and \$8.1 million in charges to cover accounting errors and airlift costs in April 1975. An example of the impact of extreme inflation in equipment costs was that the initial response to a request for enough M-113 vehicles to provide an additional squadron and replacement of combat losses stated that the price had risen from \$27,000 to \$90,000 and that it would take 5 years to achieve delivery. Only through numerous messages, which secured high-level support, and acceptance of rebuild vehicles did the price and delivery time come down. This process, so expensive in terms of manhours, was a serious problem to an austere organization such as MEDTC. Obviously, only selected items could be followed with such persistence, and many more critically needed equipment items were simply ignored for lack of funds or personnel. Thus the MAP system, with its requirements for painstaking, manual management and variable budgets was not adequate to support an army at war. The net result of all these factors was that rational program management became virtually impossible as MEDTC reacted to requirements placed upon it from higher headquarters, none of which suffered the same restrictions on personnel.

[REDACTED] [REDACTED]

[REDACTED] [REDACTED]

6. MOST CRITICAL PROBLEM AREAS. MAP procedures do not lend themselves to the rapidly changing situation encountered in war time. Long lead times on end items and two-to six-week delays in processing of program changes make reaction to immediate requirements extremely difficult and at times virtually impossible. Long-term planning, under conditions where the development of basic assumptions is at best educated guesswork, is also complicated under the MAP system.

The second major problem area, and by far the more serious, was the incremental and uncertain method of funding. Effective program management demands that managers know from the outset what funds will be available and at what point in time they will be available. Theoretically, MAP procedures should allow this; however, with MAP funding dependent upon Congressional action, the 1974-75 experience in Cambodia was one of continuous uncertainty. Operating under CRA with final program levels unspecified until late in the fiscal year made proper program management impossible.

7. CONCLUSIONS.

[REDACTED]



FORCE STRUCTURE

1. BACKGROUND: At the beginning of the reporting period, total FANK force structure had been established at a level of 253,379 with the following break-out:

Army	207,124
Navy	10,000
Air Force	12,373
Headquarters & Support	<u>23,881</u>
TOTAL	253,378

Organization of major units had been clearly defined and detailed TED (Tableau d'Effectifs et Dotation), corresponding to US TOE's, had been established for most units. Major deficiencies existed in organization of support and logistic units as well as headquarters elements for FANK and Army organizations. Air Force organization had been carefully planned and was developing in an orderly manner. Navy organization had been established, but conceptual notions concerning creation of the Mekong Special Zone, formation of additional Marine Rifle Battalions (BFM) and provision of 105mm artillery units was not integrated into the force structure, although units were being formed from territorial rifle companies.

During the reporting period significant progress was made in preparing detailed TED's for specific units and staff elements and in reorganizing units to fit a revised or modified mission. These included the Base Aéroporté (evolution and expansion of the Quartermaster Aerial Support Company); Collection, Classification and Salvage Company; Office of the Assistant Chief of Staff for Munitions; and Special Forces Command (incorporation of Medium Range Reconnaissance Battalion and Para-Commando Battalion and elimination of specific functions of the Battalion "Team" portion of the MI Battalion). It must be noted that progress in force structure occurred when it was acceptable to FANK or when FANK could be convinced of urgent necessity for reorganization. No progress was made in areas, primarily major staff organizations or logistics, where strong opposition on the part of key individuals led to intransigence despite specific guidance from LTC Fernandez, CINCFANK and Chief of Staff, to formalize the organization. Major case in point was the organization of DGI (Direction Général d'Instruction) which was never formalized because of the personal intransigence of MG Hou Hangsin. A number of proposals ended on his desk with no action taken in an apparently deliberate move to keep his organization from being fixed. This was evidently done in an effort to create a much larger empire and permit spaces for "phantom" soldiers. In another instance, Direction Général de Transport (Transportation Command) was never authorized nor could a TED be established, even though the organization was operational.

A Joint Manpower Management Review Committee was established in December 1974 and began an in-depth review of manning levels. The committee was charged with selectively reducing manning levels to achieve an overall force reduction to 223,000 and to reduce strength of headquarters and support organizations

[REDACTED] [REDACTED]

in order to provide higher personnel fill for combat units. Initial steps taken by the committee were encouraging and a major reduction of headquarters to include EMG (Etat-Major Général) and DN (Défense Nationale) were underway in March. Review of staffing of Military Regions had commenced and the considerable merit of achieving effective manpower management was apparent to FANK.

Significant progress was made in a number of specific areas, and major efforts to reorganize the Armor Brigade and the Medical Service organization and specific elements of EMG were underway at the end of the reporting period.

2. MAP. Force Structure efforts under the Military Assistance Program functioned extremely well in organization of division-level and smaller organizations. Overall force structure efforts encountered difficulty attracting command attention during the reporting period, since basic organization had been established and FANK attention was focused on operational matters. The vehicle for force structure action was in-being and responded when given proper priority as evidenced by timely establishment of a major staff element of EMG (Assistant Chief of Staff for Munitions), to include detailed TED. Significant progress was made in areas that involved interface between CINCFANK and CHMEDTC. However, new problems or areas of attention would automatically downgrade priority of effort on previously initiated projects.

FANK did circumvent MAP organization or MAP guidance whenever strong personal considerations existed. The Ninth Infantry Division (Palace Guard) was created despite strong MEDTC protests and was finally organized as a unit with a small non-MAP-supported headquarters and incorporation of three independent brigades. The Division Commander, BG Ith Suong, then used his strong political position to circumvent organizational constraints and diverted unauthorized personnel and equipment into a large unauthorized division base. Continual MEDTC efforts prevented acquisition of major items of equipment, but the result was three under-equipped, poorly trained brigades that successively collapsed under minimal combat pressure. Another instance of circumvention of MAP resulting from the wartime environment was frequent deactivation and reactivation of units. This mechanism was used to shift MAP equipment without proper supply accountability control and even as a face-saving measure to replace unit commanders. It inevitably resulted in loss of trained leaders at company level and below and loss of equipment accountability, although controls on this latter area had begun to take effect at the end of the reporting period.

3. KHMER LEADERSHIP. Although most force structure actions were well-prepared, well-executed, and well-documented, this was due primarily to COL Chan Soret, Assistant Chief of Staff, Plans, EMG. It was apparent, however, that there was an extreme reluctance to force staff finalization of the EMG force structure since this tread upon the fiefdoms of senior Khmer officers with considerable political clout. Excellent plans were not fully implemented nor properly supervised by EMG. Manpower management to insure adherence to existing force structure was non-existent until Dec 74 and resulted in large headquarters and staffs to the detriment of combat units. This is a reflection of poor leadership and supervision at all levels.

[REDACTED] [REDACTED]

[REDACTED] [REDACTED]

4. FUNDING. The major impact of funding constraints was that it continually delayed provision of planned organizations and capabilities. This applied primarily to maintenance and logistics units rather than combat units, but would have resulted in major difficulties and significant degradation of combat effectiveness if permitted to continue.

5. KC NEW YEAR'S OFFENSIVE. The major force structure action resulting from the KC New Year's Offensive was the transfer of the Mekong Special Zone away from Navy control after the collapse and disintegration of all but four BFM and all Naval Artillery units. The Mekong Special Zone was then designated a joint command under EMG, headed by an Army General with MNK and KAF deputies. All other basic organizations remained intact, but at significantly reduced combat effectiveness because of low personnel strengths.

6. MOST CRITICAL PROBLEM AREAS.

a. Deviation from MAP authorized force structure (e.g. 9th Infantry Division).

b. Lack of forceful manpower management to insure adherence to force structure. This resulted in regional headquarters at over 300 percent strength in some instances.

[REDACTED] [REDACTED]

MILITARY RICE DISTRIBUTION

1. BACKGROUND. The rice provided to the Khmer Armed Forces came from Public Law 480 (PL480) funds administered by USAID; MEDTC assisted by insuring that the FANK received sufficient amounts of rice and did not abuse the distribution and allocation systems. The MEDTC Medical Staff Officer was assigned the additional responsibility of observing FANK rice distribution. He represented MEDTC at rice meetings three to five times per week and also monitored the issues of the commodity to military personnel. FANK was represented at the meetings by the Director of Intendance and the Minister of Finance. The staff officer was also the spokesman at the GKR Rice Meetings on MEDTC policy in regard to the quantities of rice needed by FANK in order to maintain troop morale and combat effectiveness.

PL 480 rice was normally issued on the basis of 700 grams per day to each soldier and 300 grams a day for each military dependent. There were two types of rice issued to the military: "Riz Onereux" (paid rice) which the individual had to purchase and "Riz Gratuit" (free rice) which was issued to some soldiers without payment. Free rice issues commenced in December 1973, on the basis of 700 grams per day per soldier assigned to intervention units. Free rice was also issued to Air Force and Naval personnel assigned to aircraft and boat crews, respectively, and also to recruits in training centers, effective September 1974.

To oversee and supervise the distribution of rice to the military was the function of the Director of Intendance (Quartermaster). Quantities of rice required for each unit in the Khmer Armed Forces were calculated by subsistence personnel in the Bureau of Intendance based on strength figures provided by respective units. These strength figures were verified against payroll figures maintained by the FANK. The Medical Supply Officer worked very closely with the MEDTC Finance Officer and MEDTC Personnel Officer in attempting to verify that unit figures were not padded with "phantoms". All decisions concerning rice distribution for the FANK were rendered by either the FANK Rice Distribution Committee or by the National GKR Rice Committee.

Rice was issued to all military personnel in 10-day increments. Eighty-five percent of the rice distribution was made directly to units from rice warehouses located in Phnom Penh. Most units maintained logistical bases in Phnom Penh and provided their own transportation for the commodity. As of 1 April 1975, based upon the previously cited authorized daily allowance, FANK was authorized the following daily rice ration:

[REDACTED] [REDACTED]

- [REDACTED]
- (1) Free rice - 87,221 soldiers x 700 grams/day = 61.1 tons
  - (2) Paid rice - 104,376 soldiers x 700 grams/day = 63.1 tons
  - (3) Paid rice - 96,000 wives x 300 grams/day = 28.8 tons
  - (4) Paid rice - 525,000 children x 300 grams/day = 157.5 tons

TOTAL: 311.3 tons of rice met daily

It should be noted that most military families did not have sufficient funds to buy all the rice authorized and for that reason FANK, from the beginning of 1974, only needed 265 metric tons daily to feed all forces and their families supplied from Phnom Penh stocks.

2. KHMER LEADERSHIP. COL Hong Say Tang Khun, the Director of Intendance and LTC Suon Chandy, Chief of Subsistence, were two outstanding officers who appeared to be honest and extremely dedicated. Their predecessors had reputations of dishonesty, however. LTC Chandy attended the GKR Rice Meeting as the FANK representative twice weekly and presided over all FANK rice meetings.

Corruption was rampant throughout the rice distribution system, especially after the rice had been issued to the respective unit/activity or military district. Because rice was the most in demand and most marketable commodity in country, and since it could easily be sold on the Black Market, many officers were tempted to misappropriate it. Through the provision of incorrect strength figures and short issues of rice, US rice was accumulated for sale in either Cambodia or neighboring Thailand.

3. RELATIONSHIPS WITH OTHER US AGENCIES. USAID personnel assigned to the economic section were responsible for the overall management of rice deliveries into the Khmer Republic and its distribution. Most rice coming into the country was delivered to a commercial source called Sonexim (Societe Nationale d'Exportation and Importation) which managed its own rice warehouses throughout the country and made deliveries to the civilian and military rice organizations.

Primarily, MEDTC's relationship with USAID was in the verification of rice requests from units or enclaves in their demands for additional rice. Since MEDTC maintained data on troop strengths and knew of troop deployments, USAID often asked assistance in verifying that military rice requests were valid. In addition, any important policy decisions involving military rice issues required discussion and coordination of both USAID and MEDTC before being acted upon. USAID/ECON officials did on occasion make decisions on curtailing rice issues to the FANK unilaterally, not realizing its effect on military morale of effectiveness.

[REDACTED]

[REDACTED]

[REDACTED] [REDACTED]

4. KC NEW YEAR'S OFFENSIVE. Many critical problems were caused by the KC New Year's Offensive, the most serious of which was the closing of the Mekong and the inability to move barge shipments of rice coming into Cambodia from Vietnam which created serious rice shortages and required a massive airlift of DC-8s and C-130s. The rice airlift was organized on 27 February to supply 500-550 tons of rice daily. The FANK, as of the 1st of January, maintained a rice reserve of close to 30 days in their Phnom Penh warehouses and were able to resupply most units without reducing their quotas in the month of January. However, when it was concluded that the Mekong would be blockaded permanently, the FANK reduced rice issues to units and areas that had been authorized paid rice. No effort was made to reduce issues to the intervention units, in order to maintain high morale in the combat troop units. Therefore, when rice reductions were made, it was made primarily against the dependents of the military. The FANK had its daily quota further reduced to 200 tons daily in February and again in early March to 150 tons. These reductions in the rice quotas resulted in many soldiers receiving only 300-400 grams of rice a day while many military families had to subsist on near-starvation levels of 150-200 grams daily with resultant deleterious effects on morale and desertion levels. The airlift would never have been fully successful in building up adequate stocks of rice and there is no doubt that starvation of large sectors of the civilian population would have developed had the war continued. MEDTC, however, was successful in obtaining the National Rice Committee to raise the FANK rice quota to 185 tons daily on 24 March. Units still continued to pad their rice requests with "phantoms" and were also asking for additional rice. Few units realized the severity of the rice situation and continued to demand more rice.

The closing of the Mekong and cutting off of roads also complicated the delivery of rice to units and sub-regions. Cities that were previously serviced by barge or truck convoy had to be resupplied by airland or air-drop.

5. MOST CRITICAL PROBLEM AREAS.

a. Phantom Soldiers. Unit rice requests were noted upon by the FANK Rice Committee on strength figures provided by the units themselves. These unit figures were all inflated with "phantoms." It was most difficult to monitor the rice distribution system as it was too easy to subvert and too difficult to verify issues. It was impossible for MEDTC to police the program as it required traveling throughout Cambodia and involved checking units in contact with the enemy. It was estimated that about 30% of the rice distributed to units was for non-existent soldiers.

[REDACTED] [REDACTED]

[REDACTED] [REDACTED]

b. Shorting of Rice. Many units were not furnishing the proper amounts of rice to each soldier. Depending on the unit, the soldier was being shorted 10-20% of his authorized issue. Most units did not possess scales and relied on milk cans, canteen cups, helmets or any other containers available to weigh the rice issued. MEDTC was successful in getting a FANK directive published establishing 1 2/3 canteen cups as the standard issue of 7 kilos for each soldier.

c. Lack of Uniformity in Distribution of Rice. Each unit had its own method of distribution. Some units had cooperatives, pooling all their rice and cooking for all soldiers and their families. Some units issued rice at the major unit level (division or brigade); some at the company level. Some units issued rice daily to each soldier, serving the soldier either cooked or uncooked rice; other units waited every ten days to make issues. The FANK Director of Subsistence had a uniform policy established consisting of ration cards, identification photos, personnel rosters, scales, etc., but no one unit or activity practiced the same procedure. The FANK Director of Subsistence had few personnel from his office who could travel around country to inspect units to enforce FANK policy, relying on the rice distribution officer assigned to each unit or region to enforce the rice distribution system.

## 6. CONCLUSIONS.

a. A nutritionally sufficient quantity of rice was provided by the US to the FANK for its soldiers and their families. However, problems within the FANK rice distribution system deprived many soldiers of their authorized issue. Cases of starvation were reported among military families when in reality more rice had been issued than could be justified by actual strengths.

b. Without a method of maintaining accurate and valid personnel data and of organizing inspection teams, rice issue to phantoms and shorting of issues to personnel would have continued. MEDTC had neither the personnel nor the time to police a system that FANK should have supervised more forcefully.

[REDACTED] [REDACTED]

IN-COUNTRY TRAINING

1. BACKGROUND. At the time of the overthrow of Prince Sihanouk in 1970 and the subsequent rise of insurgency, the FANK in-country training base was embryonic in nature, consisting of 12 operational but inadequate service schools and two small basic training centers. The rapid increase in the Khmer Army strength from 30,000 to 220,000 was well beyond the support capability of the in-country training base.

To compensate for this inadequate training base, a massive unit and individual training effort was implemented in South Vietnam, where no-cost training by US and RVNAF personnel was conducted. This training effort terminated with the Vietnam Peace Agreement in early 1973. From early Spring 1973 to 31 December 1974, an intensive program of individual, specialist, and some unit cadre training in Thailand, augmented by increased CONUS service school training, had provided the primary source of quality training for FANK.

Since all recruit training and infantry unit training conducted at the National Training Centers (CIIIs) were accomplished solely by Khmers, it can be stated that self-sufficiency in training was achieved in these two areas. However, there was still considerable room for improvement in facilities, management expertise, and consequently in the overall quality of training. During the period 1971 through 31 December 1974, efforts to upgrade in-country capabilities were moderately successful. The training base consisted of five National Training Centers and 14 service schools. Service school and training center cadres were steadily improving as a few returnees from out-of-country training were being added to the staffs. However, priority of assignments of trained personnel was to operational units. Construction of training facilities lagged behind due to material shortages, spiraling construction costs, and reluctance of the GKR to release budgeted funds for training base support. Exigencies of the combat situation throughout the country precluded maximum attendance for school quotas. In addition, losses of skilled personnel in combat significantly impacted upon efforts to upgrade basic combat skill levels.

The Army Training Officer (In-Country) was responsible for FANK in-country training centers and service schools input to the training portion of MAP-CB. On-site liaison with all FANK training centers was one of his primary duties. He maintained personal liaison with the Office of the Director General of Instruction (DSI) and assisted in the identification of problem areas. In addition, he also participated in numerous End-Item Utilization Inspections of MAP-CB, provided infantry equipment. In conjunction with the MEDTC Personnel Evaluator, the Army Training Officer established a system of insuring a more efficient procedure of processing recruits from the various recruit reception stations to the National Training Centers.



[REDACTED] [REDACTED]

In-country training data for FY 74 and FY 75 is as follows:

(1) Training Center Capability

TRAINING CENTERS	ANNUAL OUTPUT CAPABILITY		FY OUTPUT		QUALITATIVE EVALUATION	
	FY 74	FY 75	FY 74	FY 75	FY 74	FY 75
Kampol	7,200	7,200	5,400	5,000	Good	Good
Prey Sar	12,000	12,000	9,000	9,000	Good	Fair
Kompong Speu	18,000	12,000	13,500	2,000	Excellent	Good
Sisophon	30,000	24,000	22,500	12,000	Excellent	Good
Ream	12,000	12,000	9,000	6,000	Good	Good
Longvek	6,000	-----	4,500	-----	Fair	----

(2) Service School Capability.

SCHOOLS	ANNUAL OUTPUT CAPABILITY		FY OUTPUT		QUALITATIVE EVALUATION	
	FY 74	FY 75	FY 74	FY 75	FY 74	FY 75
Officer Candidate	1,600	1,800	710	500	Good	Fair
Command and Staff	750	750	500	400	Good	Good
English Language	480	500	380	250	Excellent	Fair
Intelligence	935	720	400	20	Good	Fair
PSYWAR	1,200	1,200	670	300	Good	Good
Airborne	1,500	1,500	300	300	Fair	Fair
Armor	2,972	900	1,816	300	Fair	Fair
Engineer	2,146	2,000	989	650	Good	Good
Signal	1,720	1,720	1,575	420	Excellent	Good
Ordnance	1,335	1,335	1,175	50	Good	Poor
Medical	300	600	200	200	Fair	Poor
Transportation	2,240	2,800	1,975	350	Good	Fair
Artillery	1,660	700	1,000	500	Fair	Poor

[REDACTED] [REDACTED]

[REDACTED] [REDACTED]

2. MAP. As the intensity of combat operations fluctuated, the ability of the Khmer Army to provide qualified personnel also fluctuated. Combat operations took precedence in the continuing struggle and competition for available resources. Personnel selected to receive training were often required by their unit or simply removed from training for no apparent reason. Thus, individual as well as unit training quotas were never met and in several instances, training at the National Training Centers was curtailed. The example data below demonstrates the impact of this problem of the in-country recruit training program.

WEEK OF 21-27 JULY:

Recruits sent from training centers to units:	1,633
Recruits with less than six weeks training:	1,263 (77%)
Curtailed at 5 weeks:	509 (31%)
Curtailed at 4 weeks:	125 ( 8%)
Curtailed at 3 weeks:	253 (16%)
Curtailed at 2 weeks:	134 ( 8%)
Curtailed at 1 week:	242 (14%)

MEDTC repeatedly informed FANK of the dangers of curtailment, but no positive action was taken.

3. KHMER LEADERSHIP. FANK leadership did not support the training program as evidenced by the fact that quotas for critical courses, particularly NCO and officer courses, continually were only partially filled. To complicate the situation further, DGI did not actively supervise the non-commissioned officer training program and training center commanders returned students to their units due to minor administrative technicalities.

Another glaring example of lack of interest and support in training on the part of commanders was evidenced in the training of crew-served weapons, especially 60mm and 81mm mortars. Although DGI had developed a comprehensive program to train Mobile Training Teams (MTTs) for each Military Region, Sub-Military Region, and Intervention Brigade, the program was not supported by either unit commanders or EMG. Students quotas were not filled nor did units respond to repeated requests with names of students.

During the course of frequent visits to tactical units, MEDTC officers noted the poor state of individual and unit training in many combat units. Specifically, the following areas were of particular concern:

- (a) Weapons qualification.
  - (b) Maintenance of individual and crew-served weapons and ammunition.
  - (c) Combat training of the individual soldier.
  - (d) Fire and movement at squad, platoon, and company level.
- [REDACTED] [REDACTED]

- [REDACTED]
- (e) Night patrolling and ambushing.
  - (f) Maneuver of battalions and brigades against enemy positions.
  - (g) Employment of crew-served weapons in the defense.
  - (h) Preparation of defensive positions.
  - (i) Leadership at all levels.
  - (j) Planning and coordination between units and branches of the Army and among the three services.

These weaknesses were not remedied during the 1974 Wet Season due again in part to an apparent lack of interest and cooperation of commanders, EMG and particularly DGI. Despite MEDTC's extensive efforts to encourage improved training, a comprehensive training program responsive to FANK's critical needs never materialized. This lack of training had been a major contributing factor to battlefield failures and the high rate of casualties during the 1974 dry season.

Most commanders and their staffs at the National Training Centers were inept. One reason for their ineffectiveness was that these individuals were permanently assigned to other non-training-related functions which demanded the majority of their time, causing junior officers, by default, to assume key training roles.

4. FUNDING. MAP-GB programmed training funds were applied almost exclusively to CONUS and Third Country Training except for the procurement of training aids, books, and other training publications for in-country training. Materiel and equipment to support in-country training requirements were programmed under MAP-CB materiel program lines which caused inadvertent delays due to the order-delivery time involved.

There was a reluctance on the part of the GKR to release budgeted funds for training base support because training was always relegated a very low priority in the allocation of available resources. Consequently, a general lack of adequate permanent facilities was apparent at all service schools and training centers. Limited classroom space, student housing, messing, and other support facilities adversely impacted on the quality of training. As the bulk of the government's available resources were applied to combat operations, little progress was made in the improvement of training facilities outside of self-help programs and the quality of the in-country training program suffered proportionately.

Equipment purchased through MAP-CB to support training often was diverted to combat units to replace combat losses or used for unauthorized purposes. During the reporting period, cadre improvement remained slow. MAP-CB funds were not available to upgrade this predicament. Personnel earmarked for cadre positions upon completion of training in CONUS and Thailand were often assigned to major Army headquarters instead of training assignments, with a resultant adverse impact on the overall quality of training.

[REDACTED]

[REDACTED] [REDACTED]

Although MAP-03 was able to procure the necessary publications required in the national training centers and service schools, it was not as responsive to the procurement of badly-needed training aids. Each training center and service school lacked the necessary training aids to conduct meaningful training and fabrication of make-shift training aids was necessary.

5. RELATIONSHIP WITH OTHER US AGENCIES. In regards to the Khmer Army In-Country Training Program, the Defense Attache Office was most helpful in providing the Army Training Officer (In-Country) invaluable training information and data. Their frequent visits to intervention units enabled them to perceive how the training impacted on the combat effectiveness and performance of MAP-supported tactical units.

6. KC NEW YEAR'S OFFENSIVE. Combat personnel losses made it ever more difficult for FANK or DGI to fill in-country student quotas. In addition, personnel designated for training were often needed by their units engaged in combat and commanders at all levels were reluctant to release their student personnel.

7. MOST CRITICAL PROBLEM AREAS. The combat situation; the general lack of interest and support on the part of EMG, DGI, and commanders at all levels; and the continuous restricted budgeting procedures were the most critical problem areas affecting the entire Khmer Army Training Program.

8. CONCLUSIONS.

a. Existing in-country training capability did not quantitatively or qualitatively support the MAP-planned force structure.

b. Self-sufficiency in in-country training remained far in the future.

c. During periods of low intensity, FANK did not make any concerted effort to maximize training or to strengthen its combat capability.

d. Throughout the reporting period, EMG, DGI, and commanders at all levels lacked interest in and failed to support the Khmer Army In-Country Training Program with resultant disastrous effects on the battlefield.

CONUS ARMY TRAINING

1. BACKGROUND. The CONUS Army trainer had two prime responsibilities vis-a-vis the training of Khmer military personnel in CONUS: the implementation of the currently existing program, and the development of the program for the ensuing year. Data for the three fiscal years is as follows:

	<u>FY 74</u>	<u>FY 75</u>	<u>PROPOSED FY 76</u>
Number of Students	142	265	195
Cost	\$526,670	\$870,000	\$634,930

Implementation of the current program entailed the following responsibilities:

a. Insuring a steady, timely flow of qualified student candidates into the Defense Language Institute. These personnel had to be instructed and tested on their knowledge of the English language, with qualified personnel being processed from Phnom Penh to CONUS, via Bangkok, in time to begin class on the prescribed date.

b. Processing students upon their return to the Khmer Republic for pay, and monitoring their utilization.

c. Administering the dollar lines of the training program. In FY 75, a total of fifteen reprogramming actions involving CONUS Army training dollars were initiated.

The FY 75 program was developed in coordination with appropriate MEDTC personnel and with the Director General of Instruction. This program was presented in detail at the Tri-Service Workshop held at Taipei on 16 February 1975. Based on recommendations from the CINCPAC representatives, the proposed FY 76 program was amended to insure that each student, regardless of ECL requirement, would attend the US Defense Language Institute at Lackland AFB, Texas, for at least four weeks of English language training, the principal purpose of which was to assist the Khmer student in adjusting to the cultural shock often encountered upon arrival in CONUS.

A major additional duty of the CONUS Training Officer was to oversee the English language training program in the Khmer Republic. Additionally, he served as the Test Control Officer (TCO) for all English Comprehension Level (ECL) tests. The Khmer English language training program was fragmented into three separate entities (Army, at the Institute Militaire Langues Etrangeres (IMLE) in Phnom Penh; Navy, in Phnom Penh; and Air Force, in Battambang). Cooperation between these separate Khmer elements was less than ideal, and they did not merge their efforts, although in theory they were under a single director.

[REDACTED]

To preclude the likelihood of compromise of the limited number of ECL tests available, it was determined that the ECL test would be administered only as a final test. Screening tests and intermediate tests used the American Language Course Placement Test (ALCPT).

A third, twenty-position language laboratory was installed at IMLE in the second quarter, FY 75. This increased the laboratory capabilities at IMLE by fifty percent.

The CONUS training officer was responsible for implementation and supervision of the US Army Correspondence Course program for FANK. During FY 75, a total of 15 Khmer officers registered for 23 courses from 7 US Army Schools. This program did not receive a great deal of support from the Khmer, nor was the successful completion rate very high.

2. MAP. The Army training program was managed by three US officer personnel in Phnom Penh plus expanding administrative support in Bangkok Joint Liaison Office (JLO) where headspace was not a problem. Army training could perhaps have been more efficiently managed had the TDA allowed two officer personnel, and one admin NCO who would have handled administrative requirements for Third Country and CONUS training. The Khmer had a difficult, and most unsuccessful, problem in adapting their internal administrative machinery to the time-sensitive requirements of MAP. The establishment and timely satisfaction of suspense requirements were not compatible with the Khmer bureaucratic system.

3. KHMER LEADERSHIP. MG Hou Hangsin, the Director General of Instruction, was not able nor inclined to cause his organization to respond effectively to the myriad requirements of the MAP-supported training program. His chief assistant for out-of-country training, LTC Son Nop, was totally ineffective and apparently disinterested. He made no effort to respond with any degree of urgency to the many time-sensitive and/or long-range administrative requirements for a successful CONUS training program. Accordingly, DGI developed no internal planning or administrative capability, despite repeated efforts on the part of MEDTC to encourage such development. A long-range training planning program was non-existent, nor was there any effective record reflecting training accomplished or utilization of trained personnel.

Corruption was also a problem. Personnel were selected to attend language training (a prerequisite for CONUS training), not according to their military qualifications, but according to their ability to pay. MEDTC efforts to control those practices had some positive effect.

4. FUNDING. Fund levels presented no problem, since the training program was formulated within dollar constraints. Generated fallout dollars were more than adequate to accommodate additionally required instruction. Furthermore, MEDTC did not choose to reduce training lines when additional dollar amounts were needed in other areas. Training was considered a critical, long-term need.

The supply system proved to be satisfactory for the limited demands which were placed upon it by CONUS training requirements. The primary demands were placed upon the Defense Language Institute, Lackland AFB, Texas, and were well satisfied in each instance.

[REDACTED]

[REDACTED] [REDACTED]

5. RELATIONSHIP WITH OTHER US AGENCIES. CONUS Army training requirements demanded little interface with other US agencies. However, coordination with CINCPAC J-95 was close and continuous throughout. Informal coordination with established with USAID to obtain reading materials and posters for the English language training program. Frequent interface was required with the Embassy Consular Office (student passports and visas) and with the Embassy Finance Office (student travel pay). There was a near-constant dialogue between the CONUS training officer and Defense Language Institute representatives at Lackland AFB, at CINCPAC, and in Bangkok.

6. KC NEW YEAR'S OFFENSIVE. The KC New Year's Offensive had little apparent impact on the CONUS Army training program. Some students may have been diverted from English language training, but these changes were not obvious.

7. MOST CRITICAL PROBLEM AREAS.

a. MEDTC.

(1) The CONUS training officer should have been trained prior to his arrival in the execution of his responsibilities.

(2) MEDTC Army training personnel were organized with one officer each for in-country, third-country, and CONUS training requirements. Due to the myriad administrative requirements, personnel could have been utilized more efficiently, considering headspace problems in-country, if there had been one NCO to handle all administrative matters for all three areas (to include ITOs, test administration, etc.). Two officers could handle EICs, coordination, and planning.

b. DGI. The DGI was responsible for all training received in-country by Khmer personnel and for coordinating many administrative aspects of training received out-of-country. In all regards, DGI proved inept in this critical area. Despite repeated urging from MEDTC, DGI made no effort to follow-up on the effective utilization of MAP-trained personnel. It did little to insure that identified candidates were branch or technically qualified. DGI student input to the DLI was habitually late. Students required a minimum of six months language training to insure their attaining an acceptable ECL score. Often students had less than four months training. DGI had no sense of urgency vis-a-vis established suspense dates.

c. IMLE. The major problem at IMLE was the poor quality of instruction. Approximately twelve percent of the Army spaces for CONUS training were lost due to low ECL scores.

[REDACTED] [REDACTED]

In addition, there was no cooperation between the Khmer Army, Navy, and Air Force language training facilities.

d. CONUS COURSE CONTENT. The course content of many of the courses of instruction in CONUS, which Khmer students attended, was not suitable and/or practical for use by the Khmer Armed Forces. For example, the FA Officer Advance Course teaches technical aspects of missile employment, devotes considerable time to the 175mm and 8-inch howitzer gunnery problems (to include the nuclear gunnery problems) and instructs in artillery tactics for Corps Artillery and for Division Artillery. This instruction is far too advanced and sophisticated for the Khmer artilleryman who employed his small caliber artillery by battery and even by section.

8. CONCLUSIONS.

a. The lack of long-range planning for training and the failure to consider force structure requirements and previously trained personnel seriously detracted from the development of annual training requirements by FANK. Additionally, ineffective and poorly timed tasking by DGI for input for the ensuing fiscal year's training program yielded a product that was not responsive to the true training needs of FANK.

b. The specified goal of CONUS and third country training was to enhance the capabilities for eventual FANK self-sufficiency in training. To accomplish this, Khmer personnel trained in CONUS should have been used to improve the Khmer training base. This was not accomplished to a satisfactory degree. One limiting factor was the dire need to keep all trained personnel in military units, particularly as the intensity of war increased.

c. Students returning from CONUS training, even when they were not to be utilized as instructors in the Khmer training system, were often inefficiently utilized. The offices of DGI did little to monitor - and even less to enforce the MAP-required utilization of trained personnel.

d. DGI did not place appropriate emphasis on student qualifications for CONUS training. DGI appeared more interested in filling a space than with identifying candidates with some background in a given field.

e. The parochial and uncooperative attitudes of the three services concerning language training resources proved to be inefficient and counterproductive. This in part contributed to the less-than-optimum results obtained from language training.

f. The late input of students from DGI, untrained and inexperienced language instructors, and the lack of native speakers all contributed to an approximate twelve percent ECL failure on the part of Army students at IMLE.

g. The course content of many of the CONUS courses to which Khmer students were sent was of questionable long- or short-term value.

[REDACTED] [REDACTED]



[REDACTED] [REDACTED]

h. Program managers should be trained before assuming responsibility for dollar lines, particularly in an environment such as existed in Phnom Penh where there was no depth and where a major turnover of personnel occurred annually.

i. Organization should provide for central training administration. Separating training personnel according to service was not totally satisfactory, from a strictly training point of view.

[REDACTED]

d. When urgent requirements for additional M113 Armored Personnel Carriers became apparent, \$807,530 of FY 75 Third Country Training Program funds were identified and transferred to Army materiel lines. This action resulted in a 28 percent reduction to the FY 75 Third Country Program.

6. MOST CRITICAL PROBLEM AREAS.

a. Some background files and rationale for preparation and later modification of the FY 74 and FY 75 Khmer Third Country Training Programs and for selecting students were not available and/or incomplete. To help improve the planning and management of the training program, Army trainers established a file which contained the rationale for the development of the FY 76 Khmer Army Training Program.

b. The short tour of duty for MEDTC personnel and the resultant turnover hampered the development and implementation of an effective long-range training program. The headspace restriction provided little or no overlap between trainers.

c. An overall training plan was non-existent. Prior to the development of FY 76 Khmer Third Country Training Program, a training requirements plan was developed to assist in tailoring the FY 76 training requirements to the force structure of the Khmer Army.

d. MEDTC rarely received adequate information on costing computations of third country training. From the submission of the initial request (April 1974) for training to be conducted in Thailand to the receipt of the initial course cost data (November 1974), seven months elapsed thus delaying the start of the FY75 Thailand-conducted training.

e. Unlike other MAAGs, the preponderance of out-of-country training was conducted in a third country. However, before training funds could be expended in support of third country training, OSP certification and authority and MAP order release had to be approved by SECDEF. A delay of six weeks was experienced in obtaining such approval.

f. In regards to third country training, the procedures for planning, programming, and implementing such a program were cumbersome and time-consuming.

g. Newly-assigned MEDTC planners and programmers experienced difficulties in accomplishing their duties without some type of Phase IV training. MEDTC requested CINCPAC to consider conducting an abbreviated Phase IV training course at CINCPAC for materiel and training planners and programmers assigned to MEDTC prior to their arrival in Cambodia. The request was not favorably considered.

h. A system of skill identification of trained personnel was never implemented. Without a functioning MOS system centrally located at the national level, projecting training requirements was extremely difficult.

[REDACTED]

THIRD COUNTRY TRAINING

1. BACKGROUND. The purpose of the Khmer Third Country Training Program was to provide training not available or adequately provided for within the Khmer Republic. Its objectives were development of: training self-sufficiency for the Khmer forces; critically short specialists in skills needed for effective operation and maintenance of equipment acquired from the United States; and rapport between the Khmer Army and the United States military. The primary training priorities were demand and combat skills, logistics (maintenance, supply, procurement, and repair service), and management (administrative, executive, and training service). The Khmer Army had experienced an expansion of over 700 percent since 1969. In-country training capabilities were clearly inadequate to support such growth.

The primary responsibility of the Army Training Officer (Third Country) was to administer and monitor the Khmer Army Third Country Training Program. In addition, the Army Training Officer (Third Country) also participated in numerous End-Item Utilization Inspections which insured correct and efficient use of MAP-provided infantry equipment and munitions.

During the FY 74 Training Program in Thailand, approximately 82 percent of the Khmer Army students were trained by Thai personnel; the remaining 18 percent were trained by US Mobile Training Team (MET) and US military personnel. In FY 75, almost 70 percent of the Khmer Army students were trained by Thai personnel; the remaining 30 percent by US military personnel. Third Country training data for FY 74 through FY 76 were as follows:

	<u>FY 74</u>	<u>FY 75</u>	<u>FY 76</u>
Student spaces	1,726	1,834	1,406
Cost	\$1,711,751	\$1,760,200	\$1,653,100

Several major changes occurred in the FY 74 and FY 75 Training Programs. In FY 74, a significant portion of the training was devoted to on-the-job training (OJT). In the FY 75 Training Program, more emphasis was placed on specialized and professional training. Also, medical specialist training was programmed for the first time.

2. MAP. The Khmer Army Third Country Training Program was extremely flexible in coping with day-to-day third country training problems. This was due in part to the successful training negotiations conducted in January 1975. The savings realized provided training topics to fund additional courses (Rigger OJT, Bulldozer Rebuild OJT, AM-2 Airfield Matting OJT, Fog Boat OJT, and Printing Press) and to meet other urgent FAVT training requirements. Another reason for this flexibility was the establishment of a close rapport between all training officers.

[REDACTED]

1. Khmer personnel were not being used in the skills for which they were trained. MEDTC had advised the Commander-in-Chief of the utilization requirements and had requested, in April 1974, that assignment information be furnished to MEDTC. DGI did not respond to the repeated requests.

## 7. CONCLUSIONS.

- a. It is essential that all training officers attend the Security Assistance Management Course at Fort Bragg, North Carolina, or a related type security assistance course and be given some training at PACOM Headquarters prior to arrival in-country.
- b. Generally, the Khmer personnel in DGI were totally inept. The leadership necessary for a viable training program was completely lacking.
- c. The reorganization of MEDTC complicated accomplishment of training tasks which affected two or more services. No single service was tasked to accomplish a bi-or tri-service training requirement.
- d. Prior to costing RTA conducted training, MEDTC, MACTHAI, SCHQ (FWD), and RTA should have agreed on costing guidelines. An early agreement would have alleviated the delay in course start dates and expedited the request for OSP certification and approval.
- e. Whenever considering the military training requirements, strong cognizance must be taken of the existing level of combat. The combat environment impacted upon the number of personnel and dollars resources which were allocated to training. As the intensity of combat operations fluctuated, the ability of the Khmer Army to provide qualified student personnel also changed.
- f. The lack of adequate in-country permanent training facilities placed too heavy a reliance on third country training.
- g. The procedures for planning/programming, and implementing a third country training program were cumbersome and contributed to the delay of the FY 75 Khmer Army Third Country Training Program. The delays experienced with RTA were primarily in negotiations and costing procedures.
- h. The training objectives for the FY 75 Khmer Army Third Country Training were not fully met. Although additional emphasis was placed on specialist training, the malassignment of trained personnel contributed to ineffective operation and maintenance of equipment acquired from the US and a delayed achievement of self-sufficiency in training.
- [REDACTED]

MEDTC ORGANIZATION AND FUNCTIONS

1. GENERAL FUNCTIONS. The Military Equipment Delivery Team, Cambodia (MEDTC) functioned similar to a MAAG. With a Brigadier General as Chief (CMEDTC) it planned, programmed, ordered, and monitored the shipment and distribution of MAP material. As a tri-service organization it came under the command of CINCPAC. However, CMEDTC was a member of the Cambodia Country Team and therefore directly responsible to the Chief of the US Mission, Phnom Penh, as well. MEDTC assured the proper utilization of MAP materiel by conducting end item utilization inspections (EIUIs). MEDTC also arranged for CCNUS, third country and in-country training of members of Forces Armees Nationales Khmeres (FANK). In contrast to a MAAG, MEDTC was legislatively prohibited from advising or instructing.
2. ORGANIZATION. Assisting CMEDTC with management of MAP-CB and accomplishing liaison with DOD agencies outside of Cambodia were four divisions and two principal staff offices (See Appendix 1).
  - a. Office of Deputy Chief. This office was responsible for the internal management of MEDTC. Typical activities with which it was concerned were: administration, administrative budget, transportation, security, evacuation, protocol for CMEDTC functions, and supervision of the Joint Liaison Office, Camp Samae San, Thailand (Appendix 2). The latter office accomplished administrative support functions which could not be performed in Cambodia.
  - b. Special Assistant for Coordination and Special Actions (SACSA). The SACSA was principal assistant to CMEDTC in the management of MAP-CB. SACSA maintained daily liaison with the FANK High Command to assess materiel requirements. This office coordinated planning and programming of a joint service nature and reviewed all operational and policy correspondence for CMEDTC. It was also the focal point of coordination for all audits by GAO and DOD, inspections by State Department Inspectors and visits by congressional and other delegations.
  - c. Ammunition and Services Division. This division provided MEDTC's logistic management for ground, air, and naval munitions. It evaluated FANK management and utilization through EIUIs. In addition, it managed the movement and distribution of MAP materiel to include general cargo, ammunition, and POL. The division also provided commodity management for POL and monitorship of river convoys, highway convoys, airland, and airdrop operations.
  - d. Other Divisions. The three separate Army, Air Force, and Navy Divisions planned, programmed, ordered, and arranged the delivery of MAP materiel for their respective service components of FANK. Through regular EIUIs, each division assessed the utilization of MAP-CB materiel. The chiefs and other division members at all levels also accomplished personal liaison with their respective service components as a means of

assessing the needs of FANK. The divisions also arranged for CONUS, third country, and in-country training. Under the responsibility of the Army Division there was a Liaison Office, Bangkok, Thailand which provided detailed coordination and liaison for the third country training program. (Appendix 3).

[REDACTED] [REDACTED]

ities, off-loading locations, and airfield damage control and surface clean-up. Through the OACC, the Division opened an additional taxiway to Apron C to facilitate ground movement and aircraft flow. The Division was also involved with emergency actions to clear runways and taxiways of damaged KAF aircraft, to return damaged contract aircraft to flyable status, and to arrange for AM-2 matting to be flown in for installation by a FANK engineer battalion.

Congressional limitations on both headspace and mission significantly downgraded the potential which could have been realized if the Team had had more latitude. Because of these restrictions, the MEOTC efforts could not include operationally oriented assistance to improve the Khmer's tactical employment of MAP-CB equipment, and therefore Air Force Division members were not allowed to correct such flagrant errors as wasted sorties, unsuitable munitions selection, improper delivery techniques, and mis-oriented emphasis. Despite these restraints, the Air Force Division established effective working relationships with all major echelons of KAF. There were no instances of overt friction between Division members and their KAF counterparts. An atmosphere of mutual professional respect and cooperation existed up to the very end.

## 2. THE MILITARY ASSISTANCE PROGRAM (MAP) FOR THE KHMER AIR FORCE

The planned total MAP-CB for FY 1975 was \$362.5M, of which the Air Force portion was \$16.6M, less than five percent of the total. This figure does not include requirements for fuel, packaging/crating/handling and transportation (PCH&T) costs, aerial delivery equipment, and air munitions--all of which were included in the Ammunition and Services program--nor does it include \$1.2M for KAF out-of-country training. The FY 1975 Air Force program included no significant new investment, but consisted entirely of operational and maintenance (O&M) lines, such as technical assistance contracts, engine overhauls, spare parts for aircraft, weapons, and automobiles, components and accessories, and many consumable items necessary to support and maintain a fleet of 100 aircraft.

Because of late Congressional action, the FY 1975 program was funded under the Continuing Resolution Authority (CRA). The quarterly CRA funds allotted were based on the funding of the previous program year. When Congress finally approved the FY 1975 program in January 1975, it allocated only \$275M (instead of \$362.5M), and it stipulated that PCH&T costs of \$10M should be paid from this new ceiling. Under CRA, MAP-CB had already committed

[REDACTED] [REDACTED]

[REDACTED] [REDACTED]

almost 75% of the entire program for the fiscal year, and the year was only half over. Coupled with the start of the Communist 1975 Dry Season Offensive, this situation led to many funding problems.

The KAF had received sufficient funds in FY 1974 to support its mission, and it was making steady improvement as an effective fighting force. Based on a total expected AF program of \$16.6M (plus 1.2M for training), CRA had been approved for FY 1975 as follows:

<u>QUARTER</u>	<u>DOLLARS IN MILLIONS</u>
1st	1.3
2nd	2.9
3rd	6.7

But under the reduced Congressional authorization for FY 1975, there was no further funding for the KAF for the fourth quarter.

The KAF airlift self-sufficiency program of \$2M had been funded separately by CINCPAC in October 1974, with 1.6M from prior-year funds and the remaining \$.4M from FY 1975 funds. This program provided for six additional C-123 aircraft, along with related aerospace ground equipment, spare engines, aerial port equipment, training, and new construction.

The funding constraints of the reduced program required reprogramming of critical O&M lines, tighter screening of supply requisitions, and deprogramming of all investment funds. But, even with these austere measures, KAF still had sufficient O&M funds to support its mission. The out-of-country training programs were also fully funded.

The closing of the Mekong in February 1975 required that all cargo, including ammunition, POL, and rice, be airlifted into country, imposing further de-obligation of Air Force and other funds to support increased PCH&T costs. At first, this requirement affected only low-priority O&M funds, but as the situation deteriorated and supplemental funds were not forthcoming, 90% of KAF O&M funds were reprogrammed to support additional ammunition, POL, aerial delivery equipment, and the increased PCH&T. In late March, when the only funds available were in selected lines, such as aircraft spares and contracts, virtually all requisitioning ceased. Even with the severely reduced FY 1975 funds and the major reprogramming, KAF could have continued operating through June 1975, if fuel and ammunition had also been available.

[REDACTED] [REDACTED]



HISTORY OF MAP-CB FUNDING (\$ MILLIONS)

	FY74 PROGRAM	FY 75 PROGRAM 28 FEB 74 (A)		FY75 PROGRAM GUIDELINE 18DEC74	FY75 AUTHORIZED PROGRAM 19 DEC 74 (B)	FY75 AUTHORIZED PROGRAM 7 FEB 75 (C)	FY 75 AUTHORIZED PROGRAM 23 FEB 75 (D)	FY75 AUTHORIZED PROGRAM 12 APR 75 (E)
		REQUIRE- MENTS	SHORT- FALL					
MO	310.4	380.8	81.1	299.8	301.0	173.6	160.8	160.4
MY/SERVICES	36.3	63.6	28.6	35.0	34.0	24.9	21.9	23.2
RY	9.2	36.1	30.0	6.1	6.4	5.3	3.2	2.0
R FORCE	13.2	36.2	19.5	16.7	16.7	15.6	11.8	7.5
AINING	5.8	4.9		4.9	4.6	4.6	4.5	3.6
SUBTOTAL	<u>374.9</u>	<u>521.6</u>	<u>159.2</u>	<u>362.5</u>	<u>362.7</u>	<u>224.0</u>	<u>202.2</u>	<u>196.7</u>
NET. . . . .					51.0	53.8	55.1	57.4
OPC ADMIN COSTS. . . . .						3.1	3.1	3.4
DISTRIBUTABLE MAP MATERIAL. . . . .						14.3	14.3	13.8
ERSEAS EXCESS DEFENSE ARTICLES. . . . .						.6	.6	.5
AF AIRCRAFT MAINTENANCE. . . . .						1.0	1.0	2.0
STOTAL, MANDATORY CHARGES. . . . .						<u>72.8</u>	<u>74.1</u>	<u>77.1</u>
TOTAL. . . . .					<u>275.0</u>	<u>275.0</u>	<u>275.0</u>	<u>273.8</u>

NOTES

- A. CHMEDTC 181210Z FEB 74
- B. SECDEF 232230Z DEC 74
- C. SECDEF 291622Z JAN 75, 042305Z FEB 75, 070207Z FEB 75
- D. SECDEF 121901Z FEB 75, 211709
- E. CINCPAC 170255Z APR 75

[REDACTED] [REDACTED]

Annex G

EMERGENCY EVACUATION PLAN (NEMVAC)

1. BACKGROUND. In February 1972, the US Mission in the Khmer Republic complied with State Department regulations which require every US Mission overseas to have an Emergency Evacuation Plan. As combat around the Phnom Penh perimeter intensified, the evacuation plan for the US Mission in Cambodia came under continual review and re-evaluation. MEDIC assumed responsibility for a major portion of the evacuation planning with the approval and under the direction of the Chief of the US Mission. A detailed operations plan for joint State-Defense execution was prepared, approved and coordinated with commands and agencies outside the Khmer Republic who would assist in the evacuation.

2. NEMVAC PLANNING. Essentially, the Emergency Evacuation Plan for the US Mission in the Khmer Republic recognized three possibilities:

- a. Departure by commercial aircraft in an orderly and planned manner.
- b. Departure by military fixed wing aircraft (C-130) on short notice but unimpeded by GKR or enemy interference.
- c. Departure by emergency helicopter pickup from designated emergency landing zones throughout the city, recognizing the possibility of hostile reaction from government forces, the civilian populace, or from insurgent activity in or around the city.

More detailed planning was concentrated on this latter situation, since it represented the worst case. The city of Phnom Penh was divided into wards. Ward rosters, maps, and the mechanisms for rapid notification, assembly and departure were established. The emergency evacuation organization included a warden system, dedicated communications, airlift liaison teams, emergency assistance teams, destruction teams and a command and control element to oversee the operation.

3. OUTSIDE ASSISTANCE. United States Air Force assets stationed in Thailand were tasked to provide airlift in the event that the Emergency Evacuation Plan was executed. Since Air Force helicopter assets were insufficient to provide a single-lift capability, Commander Seventh Fleet was tasked with providing an Amphibious Ready Group (ARG) with integral Marine Aviation Unit (MAU) to assume various reaction times, dictated by the tactical situation, in order to provide both Landing Zone Security and the desired single lift capability. The decision to reduce the reaction time of the ARG/MAU to conform to the military situation in the Khmer Republic was a continuing problem, since it limited the freedom of action and scope of the training activities of the forces designated for, and dedicated to, the Emergency Evacuation Plan.

[REDACTED] [REDACTED]

[REDACTED] [REDACTED]

4. COORDINATION AND EXECUTION. Members of prospective supporting agencies were brought into Phnom Penh on a continuing basis to conduct liaison, familiarize themselves with the landing zones, communication facilities, and the command and control organization. Following an extensive drawdown of the US Mission population by fixed-wing aircraft between 3-5 April, Operation Eagle Pull, the NEMVAC Plan was executed during the morning of 12 April 1975 using the option outlined in paragraph 2c. Neither of the other options was considered feasible for reasons which follow:

a. Unavailability of ground security of sufficient size to secure Pochentong Airfield.

b. Possibility that Pochentong would be under severe enemy attack, precluding fixed-wing operations.

c. Probable necessity to employ extensive tactical air to secure Pochentong.

d. Massive vehicular evacuations to Pochentong would likely have caused general panic in the city.

e. If either of these options failed of successful completion because of pandemonium at or enroute to Pochentong, it would then have been impossible to move the Marine Ground Security Force (GSF) and evacuees back to an LZ in the city, a distance of some 9 KM.

LZ "Hotel" was selected because of its proximity to the embassy, protection from direct and most indirect fire, its ease of defense and its remoteness from heavily populated areas. Evacuees could have walked to LZ "Hotel" if it had been necessary and the entire LZ area was enclosed, providing added control and security.

5. CONDUCT OF THE OPERATION

a. The GSF of 360 marines was deployed around LZ "Hotel" and formed a double ring of troops along the fence line. One marine squad helped secure the Embassy compound. One company of marines was earmarked to secure the 700-meter route from the back gate of the Embassy compound to the entrance of LZ "Hotel".

b. The US Mission was evacuated in an orderly manner, even though all but four personnel originally having NEMVAC duties had departed Cambodia in the massive drawdown prior to Eagle Pull. All NEMVAC Wardens, assistant wardens, airlift teams, emergency assistance teams, destructors, deputy chief wardens, NEMVAC Command and Control Center (NOCC) Duty Officers and NOC's, and all but one communicator were evacuated before 12 April. With the US Mission reduced to 58, the original geographic ward system could be discarded and a new system was formed, with personnel who remained in the skeleton US Mission being named as wardens and assistants. The NEMVAC Command and Control Center (NOCC) operated with a reduced staff. Airlift teams were formed using the GSF advance party.

[REDACTED] [REDACTED]

[REDACTED] [REDACTED]

Fortunately, the destruction of most classified material had been accomplished the day before Eagle Pull, and was not a problem on the actual evacuation day.

c. The notification of evacuees was accomplished by several means: Radio, telephone, and personal contact. The radio transmission of "Battery Charger" notification messages and other NEMVAC code words was not used. Evacuees were assembled in the Embassy compound by personnel groupings: US Mission, Press, Registered/Unregistered US Citizens, Khmer employees of the US Mission and key indigenous personnel (KIP). All evacuees were identified and tagged using a four-part exchange tag. This tag served as a boarding pass and as a quick means of identification and accountability.

d. The only major problem area concerned initial accountability for certain resident US citizens and press, some of whom were unwilling to be evacuated until the very last minute, and, in some few cases, who refused to be evacuated.

e. Signal operations. Original NEMVAC planning envisioned six duty personnel/radio operators in the NOCC. The severe reduction of US personnel which commenced on 3 April 1975 left only two duty officers available. However, arrival of the GSF command and control element about a week prior to the evacuation and the decision to evacuate from a single LZ reduced command and control requirements, and facilitated airlift operations on the LZ so that the Mission of the NOCC was manageable with the reduced staff of three.

6. The evacuation operation was executed flawlessly. Its success was due primarily to complete surprise and the use of helicopters in an area known only to those personnel involved in Eagle Pull.

[REDACTED] [REDACTED]

FINANCE

1. BACKGROUND.

a. Duties and Responsibilities. The duties and responsibilities of the Army Finance Evaluator included the following: providing financial management assurance for MAP-OB with respect to monitoring, evaluating, analyzing and reporting on the development and progress of the FANK financial system, specifically the FANK centralized pay system; serving as MEDTC representative/observer on various financial management committees such as the Joint (GKR/FANK/US) Military Budget Review Committee and the FANK Pay Study Committee; coordinating with USAID on programming of US counterpart funds for FANK budget support; conducting liaison visits to various regional FANK finance offices and observing pay activities at unit level to insure compliance with the FANK centralized pay concept; reviewing, analyzing and providing recommendations on the FANK budget submission, proposed FANK pay actions, such as pay raises, new/revised allowances, pay procedures, and on the FANK finance organizational structure; monitoring and maintaining statistics on FANK finance matters, such as number of personnel paid and funds paid out.

b. Khmer Organization. Director of FANK Finance Services (BG Thach Sary) was part of the EMG staff. Frequent contact was also made with the Director of the Budget Office at the Ministry of National Defense and occasionally with various offices within the Ministry of Finance.

c. The Centralized Pay Concept and FANK Finance Organization. Prior to the implementation (Sep 73) of a centralized system, the FANK pay system was based on the French colonial decentralized method of financial administration. This system worked well for the small, largely ceremonial Khmer Army, but with the large-scale mobilization in 1970, the old system proved totally inadequate and problems of considerable magnitude surfaced. The most significant was the emergence of phantom soldiers, which were non-existent troops with whom commanders padded their payrolls. In late 1972, the FANK accepted the proposals of the US Ambassador and COMEDTC to restructure the FANK pay system and limit the paid strength to 253,378 soldiers. This new centralized pay system consisted of the following basic concepts:

- (1) Establishment of a separate and independent FANK Finance Service.
- (2) Withdrawal of the responsibility for pay of soldiers from unit commanders; vesting it with Finance Service pay agents.
- (3) Semi-centralization of payroll preparation, computation, record-keeping, and disbursing functions to include establishment of individual finance records at regional level. Eventually, these functions were to be

centralized at one location (Phnom Penh). The implementation of the revised pay system was scheduled in five phases:

Phase I - Semi-centralization of finance functions at regional level

Phase II - Issue of a unique individual pay card

Phase III - Establishment of individual finance records

Phase IV - Mechanization of payrolls--

Phase V - Validation of military dependents

Phase I was completed with the establishment and vesting of pay responsibilities in five regional finance offices. Phases II and III were considered 40 percent completed. These two phases were slow in implementation due to other higher priority efforts within FANK Finance. Key punch operators were trained for Phase IV, but no further action taken due to delays in activating the FANK computer system. Phase V was not yet begun. Under the centralized pay system, the Finance Service was removed from the supervisory responsibility of the FANK Director of Intendance (supply) and formed into a separate and independent service:

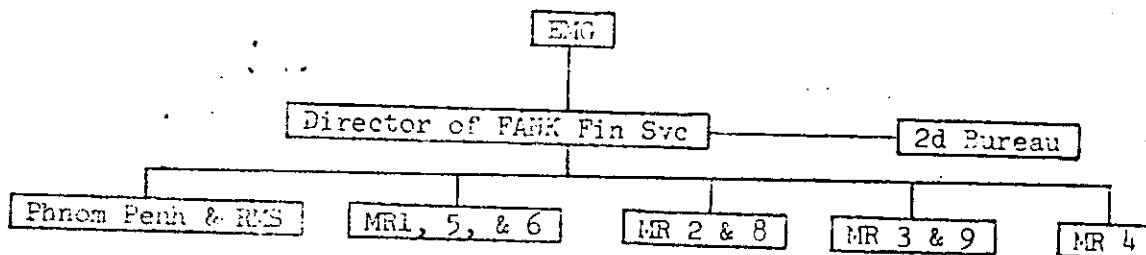

Total personnel authorized: 410

Total personnel assigned: 600

d. Amount of Funds Involved. The GKR budget for CY1974 consisted of the following elements and amounts:

Personnel Civil	16.0 Billion Riels
Material Civil	12.4 Billion Riels
Personnel Military	43.6 Billion Riels
Material Military	6.1 Billion Riels

TOTAL: 78.1 Billion Riels (\$47.3 million)

The military portion of the budget reflects non-MAP costs, principally operation and maintenance costs of FANK for which MAP-CE did not provide. The FANK payroll was the largest portion of the budget, and the average monthly paid strength for CY 74 was 250,572.

[REDACTED]

e. Changes in FANK Finance Programs. The recognized paid strength level of FANK was 253,378, which equated to the sum total of the TED strength of all FANK units to include headquarters. In September 1974, the GKR and US agreed to a reduced FANK paid strength level of 223,000 while the TED strength remained at 253,378. This reduced paid strength level permitted monetary savings to partially offset a pay raise granted to the FANK, and at the same time put pressure on commanders to reduce or eliminate phantoms. CINCFANK directed a reduction in paid strength of approximately 16 percent for all FANK units, but, due to lack of reaction time and resistance by commanders, the FANK paid strength of 223,000 was not attained. An initial reduction of 12,000 was achieved, with a further net reduction of about 4,000 over the following months.

On 31 October 1974, a Joint (GKR/FANK/US) Military Budget Review Committee was formed to provide a measure of control over the FANK budget. This committee, which met frequently, was specifically charged with reviewing and approving the monthly FANK payroll for 223,000 soldiers. The committee achieved varying degrees of success in a number of initiatives. Overall, the committee provided an excellent means of communication among the different parties on important FANK budgetary and fiscal issues. Specifically, it approved on a month-to-month basis, the FANK payroll in an attempt to institute some semblance of sound budgetary practices.

2. KHMER LEADERSHIP. The FANK Finance officers as a whole appeared conscientious, competent and willing to do a good job. BG Thach Sary, the Director of FANK Finance Services, was a highly competent officer who tried to instill dedication to finance service in his subordinates. However, many of the senior finance officers did the actual planning, writing and coordinating on finance matters, instead of delegating these functions to subordinates. Nor were they particularly innovative or forceful in pushing through what most recognized to be much-needed reforms. Most of the senior finance officers had received formal training in finance from military schools in France. Several of the field grade officers had attended the four-month Financial Management course at Ft Harrison, Indiana. Approximately fifty of the junior FANK Finance officers and NCO's had attended an 8-week finance course in Thailand in 1973. Overall, the FANK finance personnel had the requisite background and training to direct and manage the FANK pay system. Designated finance pay agents, charged with the responsibility of paying each soldier, were generally junior officers. Since these individuals were required to face senior commanders, there existed the problem of unit commanders influencing the pay agents to turn over payroll funds to them for subsequent payment to their soldiers. BG Thach Sary estimated that at least 30 percent of the payroll funds were turned over directly to unit commanders. This aspect of the centralized finance pay system was the weak link in controlling and reducing phantoms.

[REDACTED]

[REDACTED]

3. FUNDING. In the past, funds generated by PL 480 (Agricultural Surplus Commodities Act) and the Commodity Import Program (CIP) were used in partial support of the Khmer defense operating budget. This support was entirely separate from the MAP-CB program as no MAP funds were used in the FANK finance system. Sources of funds for the FANK payroll came from internally generated GKR revenues (taxes), bank advances (borrowing) and US counterpart contributions through PL 460 and CIP.

For the first six months of CY 1974, US support with PL 480 funds amounted to almost 100 percent of the FANK payrolls. Effective 1 July 1974, PL 480 funds could no longer be used for military purposes due to expiration of US Congressional authority, and emphasis then shifted to other sources. The US still provided funds through the Commodity Import Program (CIP) but at a much reduced level. Increasing amounts of borrowing (deficit financing) from the National Bank of Cambodia developed to the point where almost 100 percent of the FANK payroll was supported by this means. The total GKR budget for CY75 was projected to be 115 billion riels (military portion -66 billion riels), for which revenues were to be derived as follows:

a. Internal revenues (taxes)	28
b. US counterpart	21
c. Bank advances (borrowing)	<u>66</u>

115 Billion Riels

The large bank borrowing (deficit) was a major force driving inflation, which totalled 250 percent for CY 1974, and seriously eroded the purchasing power of the individual soldier and his family. Sources of revenue for the GKR were extremely limited especially due to the closure of the Mekong River (imports) as well as the low production base and rice level reduction in the Khmer Republic. The military budget had been reduced significantly and represented less than minimum essential requirements for personnel and material. Funds had been budgeted to support a FANK paid strength of 223,000 but actual paid strength averaged 245,000 (Oct 74 - Jan 75), and the Director of FANK Finance Services utilized pension and tax withholding funds to pay part of the excess soldiers. However, there still remained approximately 7,000 soldiers each month who received only a partial advance on payday, or who had to wait until the next payday. These excess unpaid soldiers were a major fiscal and morale problem for FANK.

4. RELATIONSHIP WITH OTHER US AGENCIES. The USAID personnel of the [REDACTED] Embassy dealt primarily with the Minister of Finance, while MEDTC personnel worked with the Minister of National Defense, RMD, and the Director of FANK Finance. USAID exerted considerable influence on the US counterpart funds which were used to support the military budget. Therefore, a close coordination developed between MEDTC and USAID.

[REDACTED]



[REDACTED] [REDACTED]

5. KC NEW YEAR'S OFFENSIVE. The enemy offensive created certain difficulties for the FANK Finance Service. With the large scale fighting and isolation/loss of units it became more difficult for the finance pay teams to pay the troops, a factor which probably increased incidents of finance pay agents' turning over funds directly to unit commanders for subsequent payment to the troops. There was continual emphasis from MEDTC to get the troops paid promptly, as pay was considered an important factor affecting the well-being and morale of the FANK soldier. During this period, it became increasingly evident that the soldier's pay was not sufficient to keep up with the rising costs of living and was therefore causing a further deterioration in his combat effectiveness. To help alleviate the problem of excess unpaid soldiers, MEDTC recommended an increase in the budget to allow sufficient funds to pay all the troops. On 2 April 1975, additional funds in the amount of 300 million riels were approved to help pay part of the excess unpaid soldiers and to partially reimburse the pension and tax withholding fund, but an additional 700 million riels was still needed.

6. MOST CRITICAL PROBLEM AREAS.

a. Phantoms. Despite good progress in reducing or eliminating phantoms, commanders were reluctant to completely eliminate their phantom strengths. It was estimated by BG Thach Sary that less than one-third of the phantom funds were used for personal gain. There were positive indications that commanders would have given up additional phantom funds if adequate operational funds were provided in lieu thereof. The Joint Military Budget Review Committee recognized that operational funds were needed and recommended the FANK budget be augmented to authorize these type funds. Actions were pending on this issue at the Minister of National Defense and Finance level when the GKR collapsed. The centralized pay system was designed to control the phantom problem when fully implemented. In the meantime, however, the problem abated only slightly, and its impact was pervasive and significant. Resources (payroll funds) were fraudulently used and, more importantly, accurate strength accounting of units for tactical operations was almost impossible to obtain. The KC offensive clearly revealed that FANK units with phantoms could not perform their missions. Estimates of the phantom level have been made, ranging from 10,000 to 50,000. It was extremely difficult to assess with any degree of accuracy the number of phantoms that existed in FANK units because accurate headcounts were impossible due to the tactical situation and dispersion of personnel.

b. PAY. The second major problem within the FANK finance area was pay for the soldier which was a contributing factor to the combat effectiveness of his unit. Late, inadequate and non-forthcoming pay had direct and adverse impact on the soldiers' morale and combat effectiveness. Soldiers were known to rebel against their commanders when they did not receive their pay, and finance pay agents had incurred physical harm when payment was not made to the troops as scheduled. The monthly pay of the average soldier was significantly less than that required to pay for the basic necessities of life. Low pay resulted in severe poverty conditions for the military member and his family which further contributed to desertions and low morale

[REDACTED] [REDACTED]

[REDACTED] [REDACTED]

Intervention units enjoyed a pay advantage over territorials, as well as entitlement to 700 grams of free rice daily. These extra entitlements had been designed as inducements to serve in combat units in an effort to raise foxhole strengths.

c. FUNDING. Financial resources of the GKR/FANK were always extremely limited. US counterpart funds were diminishing while bank advances (borrowing) became larger. There was uncertainty as to where the funds would come from to meet the FANK payroll. Delays of 7-10 days were encountered each month in securing funds and caused concern within FANK finance and among FANK units. Diminished funding levels, in effect, stymied MEDTC initiatives to implement significant pay measures designed to bolster individual and unit morale within FANK.

## 7. CONCLUSIONS.

a. The FANK centralized pay system was an important first effort to provide some measure of control over widespread phantom abuses. It achieved its initial purpose by reducing phantoms to more manageable proportions, but barring full implementation, there were ways to circumvent it and retain phantoms. Given the existing state of FANK leadership and management skills, the centralized pay system was probably too complex for the Khmer Armed Forces to fully implement.

b. Due to the high inflation rate and cost of living, the low pay of the soldier created pay irregularities, like phantoms, just to make ends meet.

c. The Joint Military Budget Review Committee was an important vehicle in the control of the FANK budget.

d. The general failure to provide adequate and timely pay to its troops was a major contributing factor to reduced morale, "moonlighting," desertions and the eventual collapse and defeat of the FANK.

[REDACTED] [REDACTED]

PERSONNEL

1. BACKGROUND. The duties and responsibilities of the Personnel Evaluator concerned monitoring Assistant Chief of Staff for Personnel (ACPER) functions in recruiting and conscription; personnel management; strength accounting; casualty reporting; computer center operations; printing plant operations; ID card issue program; the computer center project to build an organizational data base; development of an MOS system for both officer and enlisted personnel; and ACPER efforts to reduce the total troop strength to the mutually agreed-upon 223,000-man level.

During calendar year 1974, some progress was noted in nearly every area within ACPER, although the results were considerably below desired objectives. Strength accounting and an excess number of soldiers above the agreed-upon paid ceiling of 223,000 continued to be the greatest single personnel problem. Although the ACPER strength figures of 234,000 for January 1974 reflected a closing disparity between the two figures, strengths began to pick up concurrently with the impetus of the Wet Season Offensive, culminating with a yearly high of 256,000 in August. It is estimated that at least 30,000 of this figure were phantoms, with another 10,000-20,000 as highly probable phantoms. Continued pressure by MEDTC to eliminate the enormous number of phantoms succeeded in reducing the strength by 20,000 at year end, but still far from the 223,000 ceiling. Personnel gains for the year (29,140 volunteers/draftees) exceeded losses (26,763); however, this latter figure did not include wounded in action who were disabled and unable to return to duty, probably another 10,000-12,000 personnel. An intensified recruiting campaign in October, spearheaded by personal visits from the Ambassador to the Military Regions, initially promised to have good results, but fizzled out in late November and December. Recruiting figures were impressive for January-February 1975, but did not come close to total loss figures, including desertions.

Both the laminated ID card and metal ID tag issue program which were designed to combat the phantom soldier problem became fully operational during the latter half of the year with the arrival of the necessary equipment. At year end, approximately 7,000 ID cards had been issued, the majority of which went to new recruits.

The FANK printing plant, which received its basic issue of printing machinery and equipment during the year, had a limited capability. Owing to a lack of funds, basic printing supplies, including expendables, were not available to sustain day-to-day operations. Additional equipment and materials which had been ordered in the spring of 1974, but which had not arrived by year end, also hindered full operation.

The Computer Center was largely operational during the year, but, owing to internal management conflicts within ACPER, was not fully effective until the last three months. An adequate number of personnel, largely (CMT)-trained, were on hand and possessed the skills for all phases of ACP operations. Conceptually, the Computer Center was not being utilized to its fullest potential; it could have been a key management tool used to purge phantoms from rolls considerably

[REDACTED] [REDACTED]

[REDACTED]

earlier by providing reasonably accurate strength accounting. The basic causes for this lack of utilization were unfamiliarity of ACPER senior staff officers with ADP potential and a possible fear that ADP conversion would in fact expose the phantom machinations of commanders and staffs.

2. MAP. Within the limited MAP applicability to ACPER, MAP support was barely adequate. All expendables were originally programmed for procurement from commercial sources by FANK using budgeted funds; however, the rapid inflation and decreasing amount of funds available within FANK in late 1974 eroded any envisioned self-sustaining capability. A six-month basic load of MAP-supported expendables was subsequently requisitioned in early January to carry these ACPER operations until the new fiscal year.

Approximately 30 percent of the personnel assigned to the printing plant had received out-of-country training in Thailand and the Philippines, and possessed the requisite expertise to do virtually any printing job, had the equipment and supplies been available.

Generally speaking, the leadership and personnel expertise of ACPER officers were adequate. However, any initiative, comprehensive personnel planning or innovative ideas on their part were stifled by the ACPER, BG Kim An Dore, who was reluctant to do anything that would "rock the boat". This was evident in the failure to develop an MOS system, to improve the casualty reporting system, or to obtain maximum utilization of the computer center. No definitive action was ever taken by ACPER or his staff on these matters.

4. FUNDING. No particular problems were encountered with MAP funding. With the exception of funding for the expendable supplies and programming ACPER funds for future years, very little time was devoted to this area. Funds available were adequate to fill the requirements.

5. KC NEW YEAR'S OFFENSIVE. The major significant problem in the personnel area of interest was inadequate manpower. Failure to keep personnel gains on a par with, or ahead of, losses was a key factor in the defeat of FANK. A vigorous recruiting campaign was mounted after the beginning of the Dry Season Campaign which had considerable success. However, this program ran out of steam in mid-March resulting in an ever-increasing gap between gains and losses. One factor which reflected directly on the FANK leadership and which conceivably could have turned the tide was the unacceptably high desertion rate. From 1 January until 31 March, there were some 7,700 deserters, more than double the 3,769 KIA for the same period. Despite continued emphasis on means to reduce desertions, little was accomplished. One other key factor in providing a source of manpower was an apparent lack of concern by the government for total involvement to support the war. Only at the very end was any action taken to invoke general mobilization, and even then it was not sufficient to end all deferments (college and high school students, government and city functionaries, selected factories and business enterprises, Vietnamese and Chinese residents) to draw upon this pool of manpower.

Two separate actions were proposed by MEDIC/EMC staff and approved by March: Lon Nol to offset the climbing personnel losses. The first, reduction of all

[REDACTED]

[REDACTED] [REDACTED]

headquarters staffs in Phnom Penh and Military Regions, had a goal of 10,000 personnel to be transferred to combat units; in the first phase of 5,000, some 3,500 were actually reassigned. However, of these, approximately 20 percent, many of them officers, deserted and a large proportion of the others were over-age, or had physical disabilities which precluded an active combat role. The second initiative enjoyed greater initial success. It was an offer of unconditional amnesty for a 10-day period to all deserters, with immediate refresher training and assignment to combat units. Some 1,200 turned themselves in under this program; however, actual transfer to combat units was not completed at the time of US mission closure.

6. MOST CRITICAL PROBLEM AREAS.

a. Total failure of the FANK personnel management apparatus to achieve adequate strength levels in combat units.

b. Elimination of Phantoms. Although some progress was being made in the first three months of 1975 to eliminate phantoms and bring the total FANK strength levels down to the 223,000 mark, there was still no sense of urgency involved in the effort.

c. Lack of an ongoing FANK personnel support plan.

d. Reluctance of FANK to improve utilization of MAP-supplied equipment, such as the computer.

e. Troop Morale. After the onset of the Dry Season campaign, there should have been immediate action by ACPER to push for battlefield decorations to deserving soldiers who displayed gallantry in action. Such efforts, aimed as they were at troop morale, were totally foreign to ACPER particularly on the FANK leadership generally. The lack of concern for the welfare of the soldier and his family by commanders (prompt pay, issue of rice and uniforms, etc.) was a certain contributing factor to the high desertion rate.

7. CONCLUSION. Better leadership in ACPER could have enhanced overall manpower management within FANK. Whether or not the outcome of the war would have been affected cannot be determined, but a lack of adequate trained manpower and mal-assignment of trained personnel were certainly major contributing factors to the defeat.

MEDICAL

1. BACKGROUND. The Medical Services Officer was responsible for the management of the medical portion of the MAP-CB program and for auditing and monitoring all medical requisitions submitted by the Khmer Armed Forces. All out-of-country training requirements for medical personnel were developed by MEDTC. Working closely with the FANK Director of Sante, the Medical Services Officer was able to assist in solving medical problems and to provide Chief, MEDTC daily briefings on the medical situation, reporting on the number of soldiers wounded, sick, and killed by unit and location.

The FANK medical service never had adequate medical facilities to properly accommodate all military sick and wounded and their families. Most of the hospital beds for the Khmer Armed Forces were centralized within the city of Phnom Penh, with only about 400 hospital beds being located in the provinces and 390 beds scattered in regional dispensaries. This lack of hospital space for the military resulted in the FANK's occupying about 80 percent of all beds in hospitals operated by the Minister of Public Health. The civilian hospitals were incapable of providing the level of care provided by the military hospitals, since their budget was always extremely limited. In October 1974, a Joint Military-Civilian Health Committee was established to improve cooperation and assistance between the military and civilian health organizations and reduce the animosity and jealousy that had developed since the war began. The FANK Director of Sante, MG Kang Keng, strongly supported this joint medical program and provided over \$400,000 in medical supply support to civilian hospitals throughout the Khmer Republic during the period October 1974 to April 1975. Bed occupancy in military and civilian hospitals had always been greater than the number of beds available. Depending on the level of combat activity or the time of year, bed occupancy in military and civilian hospitals was between 150 to 300 percent, with many patients forced to sleep elsewhere. Hospitals were extremely short of doctors and other trained medical personnel. This situation was aggravated in the afternoon and evenings when doctors worked at their private practices. The shortage of physicians and transportation caused many seriously wounded and sick soldiers to wait hours or even days until treatment was available. Additionally, many wounded had to be operated on by nurses and other medical ancillary personnel. An accounting of the hospital beds operated by the FANK Service de Sante prior to the KC Dry Season Offensive is shown below:

<u>HOSPITAL</u>	<u>NUMBERS OF BEDS</u>	<u>AVERAGE BED OCCUPANCY BEFORE OFFENSIVE</u>
Monivong Hospital, Phnom Penh	450	714
701st Evac Hospital, Phnom Penh	760	818
400 Stat Hospital, Phnom Penh	244	352
401st Reg Hospital, Kg Cham	100	75
402nd Reg Hospital, Kg Speu	100	120

403rd Reg Hospital, Battambang	100	72
404th Reg Hospital, Siem Reap	100	118
TOTAL	1,794	2,269

Medical supply support to FANK was centralized in the city of Phnom Penh with the operation of two large medical depots; the Central Pharmaceutical Depot (PCA) and the Central Materiel Depot (MCM). The two depots, were primary distribution points for all medical supplies. The DCSS (Director Central Service de Sante) required that requisitions be submitted at least 15 days prior to the intended date of pick-up. All combat units in FANK were to requisition their supplies monthly. However, these units and hospitals could at any time submit an emergency medical supply request for medical items needed to save lives and prevent suffering. An elaborate identification procedure was established by DCSS to insure that only designated representatives would pick up supplies for their units.

All requisitions for replenishment of medical supplies and equipment were submitted directly to the US Army Medical Materiel Agency Pacific, located in Okinawa. This commodity was the only class of supply managed by MEDTC that did not requisition through the International Logistics Center. Special handling of all MAP-CB requisitions was expedited by the US Army Medical Materiel Agency, Fort Dietrich, MD, with the Defense Personnel Support Center (DPSC). The depot at Okinawa filled only 10 percent of all supply requisitions submitted by MAP-CB. The remainder were direct shipments from CONUS depots. Medical Supply support from Okinawa was truly outstanding except for a few medical supplies that had to be specially procured for Cambodia.

The medical supplies budget for FY 74 and FY 75 was about \$2.0 million below estimated requirements. Many units could not be issued all the types and quantities of medical supplies required to adequately support a military force. This condition was caused primarily by the escalating medical supply costs shown below:

<u>DESCRIPTION</u>	<u>FY 74</u>	<u>FY 75</u>	<u>FY 76 (Projected)</u>
Drugs, biologicals, dressings	\$2,100,000	\$2,205,000	\$3,873,000
Medical surgical instruments	100,000	105,000	166,000
Dental supplies	10,000	10,500	24,000
X-Ray equipment	50,000	47,561	61,000
Hospital equipment	75,000	150,000	161,000
Laboratory equipment	10,000	31,400	65,000
Other medical supplies	55,000	65,000	97,000
TOTAL	\$2,400,000	\$2,614,461	\$4,427,000

[REDACTED] [REDACTED]

Drugs and dressings, the most important line in the medical program were never properly funded.

2. MAP. The MAP system was not completely responsive to support combat medical requirements. For example, the use of Chloroquine-Primoquine and Chloroquine-Phosphate did not help in completely eliminating malaria. Newer and better drugs were available for the treatment and prevention of malaria, but were not available in the MAP-required Federal Supply System. It was only after almost six months of correspondence that permission was granted to procure, off-shore, the most effective anti-malaria drug in the world, "Fansidar". The Federal supply system did not provide drugs that were effective in combating *Falciparum* malaria. The MAP system also constrained the expansion and support of needed medical facilities in the city of Phnom Penh, as the system only recognized MAP support for the 400-Bed Station Hospital.

MAP training for medical personnel was improving with the introduction of medical specialist training at the US Air Base Hospital, Utapao, and with the planned medical MTT for combat medical specialists at Camp Samae San in May. However, CONUS training was not relevant as it stressed administrative programs and not the more urgently needed technical skills such as surgery, anesthesia, dentistry, medical maintenance, radiology, etc.

The utilization of medical supplies and equipment could never be efficiently evaluated due to inadequate manning levels. The Military Equipment Delivery Team should have had a medical doctor assigned who could have worked with all the hospital professional staffs. Although FANK DCSS eventually learned to conform to the MAP system, he had no concept of the status of MAP funds or the need to economize on the use of supplies. A Korean TCN from Vinnell Corporation maintained all medical equipment for the FANK.

3. KHMER LEADERSHIP. Major General Kang Keng had been the FANK Director of Sante since November 1972. He had been the personal physician to Marshal Lon Nol for many years and had been closely associated with him in the political affairs of Cambodia. There was no evidence that MG Kang Keng was involved in corrupt practices. He was a hard worker and natural leader and was vitally interested in improving the health of all soldiers and their families. He did not, however, enforce discipline, particularly working hours, as officers of the Service de Sante usually only worked for a few hours a day. The FANK medical service had two other general officers, BG Tip-Man and BG Li Chum Hau. These officers were rarely at work and were more interested in their private affairs.

4. FUNDING. The MAP medical budget was not adequate to procure the quantities of drugs and dressings needed to support an army in combat. The high casualties experienced during the 1975 Dry Season required additional drugs and dressings for all combat units and hospitals. Yet, at this most critical period, the medical program had to relinquish \$300,000 in needed medical funds to other MAP lines in order to procure ammunition and to buy air delivery equipment. The inability to know how much money would be available in the early part of the fiscal year delayed requisitioning many needed medical supplies. Every effort had been made to take advantage of medical excesses available from Okinawa and obtaining medical supplies at reduced prices in order that funds would be on hand to last

[REDACTED] [REDACTED]



[REDACTED]

throughout the Dry Season. Vitamins, anti-malarials, and skin preparations were reduced in quantity in order that significant quantities of anti-biotics, plasma, and combat dressings would be available for the treatment of wounded.

5. RELATIONSHIP WITH OTHER US AGENCIES. The primary coordination made by the MEDTC Medical Supply Officer was with USAID. MEDTC worked very closely with USAID as 70-80 percent of all civilian hospital beds were occupied by military patients. Ambassador Dean, who was vitally interested in the military and civilian health organizations, called a meeting in October 1974 with officials of the US Embassy to plan for the joint utilization of supplies and medical personnel. This program was patterned after those established in Vietnam.

6. KC NEW YEAR'S OFFENSIVE. At the time of the KC New Year's Offensive, hospital facilities in Phnom Penh were already over-burdened by the Bassac campaign which had produced high casualty rates in October-December 1974. On 1 January, FANK had only 1,394 hospital beds in Phnom Penh and these were already occupied with over 1,800 patients. The civilian hospitals in Phnom Penh were also extremely overburdened, with over 100 percent of their 1,407 hospital beds occupied. Since the enemy offensive centered in and around Phnom Penh, it caused a greater number of wounded to be treated within the city. The medical supplies within the drug and material depots were amply stocked prior to the start of the offensive and all requests for units and hospitals were quickly processed. The medical depots in Phnom Penh remained open 24 hours a day, and priority was given to intervention units that were in contact with the enemy. The Service de Sante had no contingency plans for the expansion of FANK medical facilities. MEDTC obtained over two thousand beds and cots for both the military and civilian hospitals in order to accommodate military wounded. The hospitalization rates in Phnom Penh of military sick and wounded during January through March were as follows:

<u>MONTH</u>	<u>WOUNDED</u>	<u>SICK</u>	<u>TOTAL</u>
January	5,765	1,284	7,049
February	4,313	1,134	5,447
March	4,927	1,189	6,116
TOTAL	15,005	3,607	18,612

This hospitalization rate was over 200 percent higher than had previously been experienced. In addition, a greater part of those hospitalized were seriously wounded, and required longer periods of hospitalization. The additional beds requisitioned by MEDTC and the establishment of two convalescent hospitals for military wounded helped ease the overcrowding. The number of hospital beds operated by the FANK medical service available on 31 March was as follows:

<u>HOSPITAL</u>	<u>NO. BEDS &amp; COTS</u>	<u>BED OCCUPANCY AS OF 31 MAR 75</u>
Monivong Hospital Phnom Penh	950	929

[REDACTED]

701 Evac Hospital Phnom Penh	1,200	1,265
400 Station Hospital Phnom Penh	700	750
401 Reg Hospital Kg Cham	100	120
402 Reg Hospital Kg Speu	170	247
403 Reg Hospital Battambang	200	235
404 Reg Hospital Siem Reap	150	161
<b>TOTAL</b>	<b>4,170</b>	<b>4,337</b>

FANK alleviated the medical situation by incorporating additional beds within certain FANK medical facilities. In addition, the FANK medical service provided over 600 beds and cots to Khmer civilian hospitals for the care and treatment of military sick and wounded. Prior to the offensive, the Minister of Public Health operated only 1,644 beds in 4 major hospitals in the city of Phnom Penh:

<u>NAME OF HOSPITAL</u>	<u>PRIOR TO OFFENSIVE</u>	<u>31 MARCH 1975</u>
Preah Kat Mala	592	800
Khmer-Soviet	512	700
Sathearanaroth	300	520
Russey-Keo	240	270
<b>TOTAL</b>	<b>1,644</b>	<b>2,290</b>

The FANK medical service faced numerous problems during the Offensive. These included: shortages of certain types of medical supplies; a lack of medical evacuation means; difficulty in delivery of medical supplies; misappropriation of supplies; shortage of physicians; and the lack of medical facilities and beds.

The high numbers of wounded created an immense surgical workload on all hospitals in Phnom Penh. The Khmer medical service only had 18 surgeons on active duty and these surgeons, bearing military duties with their private medical practices, worked long hours. The city blood bank had difficulty providing adequate quantities of whole blood and MFF. During emergency requisitions, obtained over 5,000 bottles of serum albumin to help cope for this shortage.

[REDACTED] [REDACTED]

The establishment of a new Triage Center (emergency clearing/sorting/and treatment center) in February 1975, in the gymnasium at the Olympic Village, was a major medical treatment improvement. All military sick and wounded coming into Phnom Penh were treated at this one facility, to include removal of bullets and shrapnel, setting of fractures, and amputations. Once treated at the Center, the patient was sent to one of the military or civilian hospitals in the city, depending on the type wound and bed availability.

#### 7. MOST CRITICAL PROBLEM AREAS.

- a. Lack of Medical Personnel. The FANK Medical Service was authorized by TED a total of 296 doctors for medical facilities and combat units. Yet, the largest number of physicians that could be mobilized at one time was only 68. Of these, only about 18 were qualified surgeons, with the remainder being general medical doctors. Of the 66 doctors in FANK, there were 43 doctors stationed in Phnom Penh. The FANK Medical Service was also authorized 3,231 nurses; 1,694 were assigned. The shortage of doctors and nurses was more acute in the areas outside of Phnom Penh, especially in the enclaves. Few doctors could afford to give up their source of income by going to these isolated areas. The FANK Surgeon General knew of this problem, but because of the political influence of many of the physicians, dared not transfer any of them outside Phnom Penh.
  - b. Limited Medical Support in Intervention Units. Each division was authorized a mobile surgical hospital of 75 beds. There were four such surgical hospitals in existence at the start of the Offensive but only two (3rd and 7th Divs) were considered effective. The surgical hospitals were all well-equipped with MAP medical equipment, but for the most part only had one doctor assigned and limited surgical capabilities.
  - c. Lack of Expansion Capability. The FANK medical service failed to survey their medical facilities to determine their expansion capability - the maximum number of beds each medical facility could accommodate. Had an expansion survey been conducted, hospital beds and equipment could have been pre-positioned, thereby eliminating many of the problems of overcrowding. Many private clinics and hospitals should also have been surveyed for use by the government.
  - d. Limited Medical Budget. The MAP medical budget was too limited in funds, especially in drugs and dressings, to support medical treatment for FANK. The FY 75 medical budget was effectively \$2.3 million, while \$4.3 million was required to provide proper medical care.
  - e. Inadequate Medical Distribution System. There was an over-centralization of medical supply and maintenance functions in Phnom Penh. The issuing of all supplies from the depots in Phnom Penh was convenient to units located in the vicinity of the city, but a definite obstacle for those units and activities located a distance away.
  - f. Shortage of Medical Evacuation Means. Many soldiers died because of a lack of medical evacuation transportation by road or air. Helicopters for medical evacuation were needed, but rarely available. Wounded, on occasion, paid money in order to be evacuated by air.
- [REDACTED] [REDACTED]

[REDACTED]

8. CONCLUSIONS.

a. An erroneous attitude existed within DIRSANTE that medical treatment during combat could be provided by a part-time medical staffing.

b. Action was never taken to mobilize all medical personnel and medical facilities in country. A need existed for 200 additional doctors.

c. Medical personnel and facilities were concentrated in Phnom Penh, resulting in a dearth of doctors and hospitals in outlying areas.

[REDACTED]

THE KHMER NAVY1. GENERAL.

a. Situation. On 31 December 1974, the Khmer Navy, the Marine National Khmer (MNK), had 179 vessels and craft and 12 battalions of naval infantry - Battalion of Fusilier Marine (BFM)-defending major naval installations and manning key choke points along the lower Mekong River. Total authorized force strength was 15,451. MNK maintained its vessels and craft at three major locations: in Phnom Penh (at the Chhri Chang War Navy Base) and in Neak Loeng for riverine operations, and at Ream Navy Base for coastal operations. In addition, smaller forces were stationed at KS Chhnang on the Tonle Sap River and at KG Cham on the Upper Mekong. MNK had an excellent maintenance capability supported by a modern supply system and more than adequate stocks of material and supplies. Led by its Chief of Naval Operations, RADM Vong Sarendy, this force, though never before seriously challenged by the Khmer Communists, did not suffer any major setback until the 1975 Dry Season offensive.

By 12 April 1975, MNK had suffered high losses in craft, primarily on the Mekong River, as follows:

<u>1975</u>	<u>PER</u>	<u>LCM-6</u>	<u>LCM-8</u>	<u>MONITOR</u>	<u>MSM/P</u>	<u>ATC</u>	<u>OTHER</u>	<u>TOTAL</u>
January	2	3	-	1	-	1	-	7
February	6	5	1	1	-	4	1	18
March	6	3	-	2	2	2	-	15
April	4	-	-	-	-	-	1	5
TOTAL	18	11	1	4	2	7	2	45

This compares with a total loss of 27 craft lost from 1970 thru 1974 (See Appendix 1). Of equal significance were losses in trained boat crewmen. By 12 April, 70 percent of the crewmen assigned to riverine craft on 1 January had become casualties. The Khmer Marine counterpart, BFM, formed in May 1973 from green territorial troops, and never thoroughly retrained under MNK officer leadership or really battle-tested, had lost their positions on the critical Mekong LOC and attempts by EMG to reinforce or subsequently to retake these key points with Army forces had been completely frustrated. The BFM-poorly equipped, poorly trained, and poorly led-were no match for the KC forces, who attacked their battalion-size positions in greater strength. The loss of these critical choke points, and MNK/FANK's inability to reinforce and retake them, made transit of the Mekong too costly. Repeated attempts by MNK to perform convoy escort and logistic resupply missions resulted in loss after loss. In short, the inability of the GKR to hold the river banks accelerated destruction of the MNK as an effective force capable of performing its mission.

[REDACTED] [REDACTED]

b. Leadership. MNK's major weakness - one that impacted adversely across the spectrum of its activities - was leadership.

Leadership, including a sense of responsibility, decision-making, and communications, was the weakest point in the Khmer make-up. This weakness stems primarily from the Buddhist influence - the belief that man responds to events rather than being able to influence his course by positive action - and was, in MNK's case, exacerbated by the presence of a Khmer rarity, one strong leader, willing to take positive action.

RADM Vong Sarendy had been CNO for five-and-a-half years and had seen MNK grow from a 1,500-man unit to a force 10 times that size. He continued throughout this period to concentrate complete authority in his position, refusing to delegate appropriate responsibility to subordinate levels in the chain of command. Given Khmer proclivities, this arrangement was wholly satisfactory to the MNK officer corps and hence strong intermediate leadership was never developed. This weakness manifested itself in other debilitating ways. The Khmer preferred to take their problems, even within MNK-and certainly vis-a-vis the other services - to MEDTC for liaison and resolution. Coordinated actions between two FANK services, without MEDTC as instigator and referee, were virtually nonexistent. In addition, the sense of urgency that obtains from active participation in the management process, and the belief that one can in fact influence the course of events, were almost totally absent from the MNK officer corps. The officer corps was, therefore, reactive and, perhaps also weary from many years of conflict, and did not display the aggressiveness found in a hierarchy where leadership is stressed as an attribute and gauge of individual proficiency. As a consequence, when the intensity of KC activity rose along the Lower Mekong, MNK did not have the confident, aggressive "on-scene commanders" that are essential to success in combat.

As individuals, most MNK officers demonstrated reasonable competency within their specific areas of concern. The prerogatives each enjoyed within his sphere of command were jealously guarded and considerable self-interest was evident on occasions requiring interface between two bureaus or activities. This situation mitigated against creation of a totally cohesive force. In addition, there was a pronounced disinclination toward conducting unannounced inspections or spot checks of operating activities. Where the western military organization views such action as requisite to good leadership and demonstrative of interest in personnel, environment, and mission, the MNK held that these activities indicated lack of trust and confidence in the subordinate concerned. In sum, the lack of positive leadership in the officer corps was a long term fault which operated to weaken the performance of MNK as an integrated naval force.

[REDACTED] [REDACTED]

[REDACTED] [REDACTED]

## 2. OPERATIONS.

### a. Mekong LOC.

(1) The Mekong River was considered the lifeline of the Khmer Republic. On 21 May 1973, the Mekong Special Zone (ZSM) Plan was approved by CINCFANK in order to have unity of command for the essential uninterrupted resupply of Phnom Penh by convoys. In establishing this special zone, MNK was given the responsibility for security within the corridor which included 4 KM along each bank and was to obtain requisite forces in order that the enemy would be denied sanctuaries along and behind the river banks. The ZSM concept envisioned the transfer of Army units to MNK in order to avoid the command and control problems that had proven inherent to combined FANK operations. It was realized that an increase in MNK strength would require a corresponding decrease in other FANK forces, but the crucial importance of the Mekong River was an overriding consideration both militarily and economically to the Republic. However, the steadily deteriorating military situation in the Khmer Republic did not permit FANK to assign the necessary in-place forces that would have been required to control the banks along the Mekong. The extensive use of mobility afforded by the river itself and keyed to convoy movement was considered as a possible solution and was therefore attempted.

(2) At the same time, to promote coordination and cooperation between the Republic of Vietnam and the Khmer Republic in areas of mutual concern, a Tripartite Deputies Conference was established in accordance with SECSTATE MSG 020222Z MARCH 1973. The Tripartite Deputies were primarily concerned with Mekong convoy matters and met monthly in Phnom Penh. Principal participants were:

MG HUNT, Deputy COMUSSAG (United States)

MG THONG VAN FANMUONG, Deputy Chief of Staff, FANK (Khmer Republic) and

BG TRAN DIHN THO, J3, JGS, RVNAF (Republic of Vietnam)

Other ranking military officials of the three nations, including CHMEDTC, were invited as observers. In addition, four "working groups" met approximately once a month in Saigon to study problems and make recommendations to the Deputies. The study groups were:

Air-Ground/Mekong Riverine Operations

Vietnamese and Khmer "Problem of Pursuit"

Radio Communications between PVNAF and FANK

Intelligence Coordination

(The working groups continued to function well into the Khmer Communist Dry Season offensive, with the last meeting conducted in Saigon on 27 February 1975.)

[REDACTED] [REDACTED]

[REDACTED] [REDACTED]

(3) During the 1974 Wet Season, the enemy had been successful in closing the principal land LOC's. This created a heavy burden on the MNK to satisfy ever-increasing logistic lift and escort requirements. Although both material and personnel assets were overtaxed, ninety-two percent of all commodity imports to the Khmer Republic during 1974 were transported via the Mekong. The average monthly commodity shipments in thousands of metric tons were:

AMMO	9.8
RICE	22.4
POL	18.1
GEN. CARGO	<u>6.8</u>
TOTAL	57.1

(4) Intelligence reports had indicated that the enemy's objective in 1975 was to seriously threaten the survival of the GKR capital through the closing of the Mekong LOC, by exercising control over key stretches of river banks and by serious harrassment of the convoy ships/barges. Realizing the increased criticality of the Mekong LOC, EMG tasked the CNO (PADM Sarendy) to develop and implement a plan for the Mekong Special Zone (ZSM). The plan, Opening of The Lower Mekong, dated 5 January 75, was developed but not implemented because of the critical shortage of FANK personnel and equipment. The plan specifically called for ground sweep operations, including M113 squadron and 105mm battery support, to be launched against located/suspected enemy positions on the river banks. In addition, security operations would be launched in the proximity of known choke points to deny their eventual use by the enemy for attacks against the convoy. The helicopter lift capability was included to permit the leap-frogging of security forces ahead of the convoy, thereby off-setting shortages in personnel and increasing coverage. Special Forces elements would be utilized to conduct ambush operations and artillery would gain increased importance, thereby reducing the air support requirement. Once the requisite forces were assigned in accordance with the ZSM plan, they would be tasked to patrol these areas of responsibility in an aggressive manner and seize the initiative from the enemy and deny him sanctuary along and behind the river banks. Based on prior experience, convoy passage times would be adjusted to enable transit through dangerous areas and/or choke points during hours of darkness. While darkness effectively impeded the KC ability to spot and train weapons on the convoy, passage through these dangerous areas at night reduced the KAF capability to provide the badly-needed suppressive fire against the enemy. On the plus side for night convoy movement, muzzle flashes from the Khmer Communist guns enabled the MNK riverine craft gun crews to sight their machine guns and adjust the 105mm batteries more accurately for suppressive fire. Huey gunships were to remain on station over the convoy to provide responsive suppressive fire. The plan was an excellent piece of staff work from a US Staff College viewpoint; however, for the Khmer, it was simply a grandiose "joint plan", beyond their level of sophistication to implement.

[REDACTED] [REDACTED]



[REDACTED] [REDACTED]

(5) Early in their 1975 Dry Season offensive, the KC gained and maintained control of critical choke points South of Neak Loeung which enabled them to fabricate and emplace barricades across the navigable river channels and mine at least two of them.

Investigation of the barricades by MNK indicated that they were constructed of either nylon line or wire rope, supported by bamboo floats at intervals to provide the proper catenary to prevent passage of the heavy riverine craft. The nylon line and wire rope used in these barricades was presumed to have been salvaged by the KC from tugs sunk during earlier Mekong convoy operations. Although there was no evidence to substantiate it, MNK officers were of the opinion that the bamboo floats supporting the barricade nylon/wire ropes also supported contact or command-detonated mines to deter any attempts to breach the barricades. Mines had been responsible for the sinking of six convoy tugs and, therefore, as of February 1975, command-detonated mines in the Mekong River were considered the number one threat to convoy tugs and barges, the last of which transited the Mekong River on 26 January 1975.

The MNK mine countermeasure capability was oriented against the command-detonated mines. Power-actuated cutters were procured to cut wire rope/cable or nylon line barricades. Enemy action in the vicinity of Dei Dos caused the situation to deteriorate even further. The Khmer Communists gained control of and heavily fortified the high river banks, from which they fired with devastating effect on riverine craft attempting to resupply Neak Loeung, the GKR's only downstream logistical base.

Without doubt the KC 1975 Dry Season offensive was well-conceived, well-planned and more importantly, extremely well-executed. The KC closed the Mekong in a methodical manner, meeting only minimal resistance. On 13 February 1975, EMG relieved MNK of responsibility for the Mekong corridor and established the Mekong Special Zone as a Joint Headquarters under Army command, and directly responsive to EMG. Regrettably, the subsequent capture of Neak Loeung by the Khmer Communists on 1 April 1975 precluded further consideration of regaining control of the Mekong. This event marked the end of even limited Mekong convoy operations by the GKR and made inevitable their complete dependence on air for resupply of Phnom Penh.

(6) MNK craft losses had been extremely heavy during this period. In the first three years of the war, MNK lost 7 craft and in all of 1973, only 5 craft were sunk. During February 1974, MNK lost 1 LCM-6 to enemy action and then suffered particularly heavy losses in March and April in the resupply and defense of Kompong Luong, when 2 LCM-8's, an Armored Troop Carrier (ATC) and a PER were sunk. Two craft were lost during the months of June and July, one PER at Prek Tamerk and 1 LCM-6 at Kompong Luong. Another period of heavy losses was August and September 1974 when, on two separate convoys to Kompong Cham, a total of 6 craft were lost. During one operation, a PER was sunk and a Monitor exploded when its

[REDACTED] [REDACTED]

[REDACTED] [REDACTED]

ammunition supply was hit. In a subsequent convoy, an ATC, an LCM-6 and a PBR were lost. One Monitor (AC-8) was lost to enemy action in November 1974. This brought the MNK loss to 15 craft in 1974, for a total of 27 craft since the commencement of hostilities. During these operations, the enemy used to good advantage B40 and B41 rockets and 75mm recoilless rifles. A contributing factor to the losses suffered on the Mekong was the strong current during the Wet Season, which reduced the forward speed of craft to about 1 knot at the time of engagement.

During the month of January 1975, 3 LCM-6's, 1 Monitor, an Armored Troop Carrier (ATC), and 2 PBR's were lost. February was a most disastrous period for the MNK, when 4 Armored Troop Carriers (ATC), 6 PBR's, 5 LCM-6's, 1 LCM-8, 1 LCM-3 (Crane), and a Monitor were lost due to enemy action. During the month of March, MNK continued night convoys to deliver ammunition and rice to Neak Loeung. Shuttle convoys using riverine craft for resupply were also conducted between Neak Loeung and downstream FANK positions S1 and S2 until their capture by the KC on 7 March 1975. The urgency of FANK-directed daily convoy resupply operations to Neak Loeung kept the pressure on MNK for maximum lift capability. During these efforts in March, the enemy sunk 6 PBR's, 3 LCM-6's, 2 ATC's, 2 AC's, and 2 MSR's. The KC also destroyed Mobile Support Base #2, located at Neak Loeung, during the attacks against that city. Khmer Communist fortifications along the Mekong river banks at Dei Dos, including another barricade, restricted the passage of MNK riverine convoys between Phnom Penh and Neak Loeung. The majority of convoys running this gauntlet of fire sustained severe battle damage and high personnel casualties, including experienced boat crews. During the month of April, 4 PBR's, and 1 LCM-3 were known lost to enemy action.

b. Post Mekong Operations. With the cessation of convoy operations and the deteriorating military situation around Phnom Penh, MNK reorganized daily operations into five significant categories to meet priority requirements, as follows:

(1) Mekong Gunfire Support (GFS) and Patrol Unit. 1 Monitor, 3 Armored Troop Carriers, and 3 PBR's. This unit operated between parallels 65-70 and provided gunfire support to FANK Army units along the river banks; interdicted Route 1 running parallel to the west river bank and denied the KC use of the Mekong north of Dei Dos (parallel 59).

(2) Tonle Sap Gunfire Support Unit. 2 Monitors (1-105mm and 1-40mm), 1 Armored Troop Carrier and 1 PBR. The unit operated in proximity to Prek Phnou and provided GFS to Army units in the area.

(3) Chruai Chang War (CCW) Defense Unit. 2 Monitors, and 2 Armored Troop Carriers stationed in the center of the Mekong between CCW and the east river bank to provide GFS and defense against swimmer attacks. A PBR was assigned during hours of darkness to provide additional anti-swimmer protection.

[REDACTED] [REDACTED]

[REDACTED] [REDACTED]

(4) Medical Evacuation Unit. One PER maintained on station on the Tonle Sap River to provide MEDEVAC support to the FANK 5th Brigade at Prek Phnou, one of whose battalions was positioned on the east bank.

(5) Upper Bassac Patrol Unit. 3 PER's in vicinity of Route 1 bridge to prevent sapper attacks; and 2 PER's at Takimau to provide support to FANK Army units.

These units were actively operating on 12 April 1975 when MEDTC departed Phnom Penh.

c. Final MNK Craft Status. The following listing is of MNK craft status and location as of 12 April 1975. With the exception of the craft located at Ream and at An Long RVN, it is assumed that all remaining craft fell to Communist control.

	<u>OPERATIONAL</u>	<u>INOPERATIVE</u>
<u>Chrui Chang War</u>		
PBR	30	8
AC (105mm)	2	1
AC (40mm)	2	0
ATC	9	2
ASPB	3	2
MSR	1	0
MSM	2	0
LCM-8	1	1
LCM-6	5	3
ZIPPO	1	0
SALVAGE BARGE	1	0
LCU/YFU	2	0
YTL	0	3
YD	1	0
AFDL	1	0
MOBASE	1	0

[REDACTED] [REDACTED]



	<u>OPERATIONAL</u>	<u>INOPERATIVE</u>
<u>Kompong Chhnang</u>		
PER	2	0
<u>Kompong Cham</u>		
PER	2	0
ATC	1	0
<u>Ream Naval Base</u>		
PC	2	0
LSIL	1	0
LCI	1	0
LCU/YFU	3	1
PCF	16	3
LCM-6	4	2
PER	3	1
<u>An Long, RVN</u>		
PER	4	0
AC (105mm)	2	0
ASPB	1	0



[REDACTED] [REDACTED]

3. PLANNING/PROGRAMMING.

a. Planning. The planning section of Navy Division worked very closely with MNK on matters concerning support of contingency plans and staff studies to aid in the support of the Khmer Navy's effort to counter Khmer Communist aggression. The preparation of MEDTC's input for the Khmer Navy into the Joint Strategic Objectives Plan (JSOP) highlighted the need for a major revision to the force structure to realistically reflect changes in the combat situation.

b. Programming.

(1) The Navy portion of MAP-CB for FY75 was programmed at \$7.7 million. In late December 1974, the FY75 MAP-CB was approved by Congress at a much lower level (\$275 million) than that for which plans had been developed (\$362.5 million). The Navy share of this reduced level was \$5 million. This required an immediate foreclosure of \$1.1 million of planned expenditures and a flurry of reprogramming actions to realign the program. Most of the \$1.1 million reduction was taken from investment items to ensure continuity of operations and maintenance capability. The only major investment items retained in the program were 9 LCM-8's; five of which were procured. Expanded airlift and airdrop requirements in March-April resulted in the reprogramming of all unobligated Navy funds, with the exception of minimal amounts required for operations and maintenance.

(2) The MAP is not considered a viable method for providing material support under wartime conditions. Incremental funding and inflexibilities of the system preclude the rapid and timely action required to ensure immediate replacement of critical investment items lost in combat. In addition, such unknown (and therefore unprogrammed) charges as increased packing, crating, handling and transportation (PCHST) requirements and ammunition price escalations play havoc with a system that requires detailed planning and justification well in advance of approval of the program.

[REDACTED] [REDACTED]

[REDACTED] [REDACTED]

4. CRAFT ACQUISITION. During CY74, thirty-two MAP-supported craft were delivered to MNK (22 PBRs, 6 Monitors, 2 ATCs and 2 ASPBs). Although there were no craft deliveries in CY75, the following acquisitions were programmed/pending as of 12 April 1975:

a. Floating Drydock AFDL-25. This 1000-ton capacity craft was towed from its Inactive Fleet site at Puget Sound to Singapore for activation and loan to Cambodia. The industrial work (funded by FY73 monies) was completed March 1975 and the AFDL-25 was towed to Subic Bay for safekeeping. It was intended that AFDL-25 be anchored at Chruai Chang War to function as a supplement to the existing 350-ton floating drydock.

b. Five LCM-8's from Okinawa. Nine LCM-8's were programmed for activation under RCN 5TE35, using CRA funding. Passage of the FY75 Foreign Assistance Act with a \$200M NOA ceiling prompted a reduction of LCM-8 acquisitions from nine to five, at a cost of \$133K per craft including rehabilitation costs. These craft were located at USAGO, Machinato, Okinawa. Activation of the five craft commenced January 1975 at Okinawa and included installation of stand-off blisters and foaming of hull and blister voids for enhancement of hull protection and survivability. Following this industrial work, these craft were shipped by Military Sealift Command to South Vietnam for wet storage until the Mekong River was reopened. Interim loan of these craft to SVN was approved by SECDEF in April 1975.

c. FY74 Section 506 Drawdown Craft. These include the following:

(1) Six PER's. Funding for acquisition of six PER's from USN assets was included in the FY74 appropriation. Since the craft were not available, further action was discontinued.

(2) Three LCM-8's. USN craft more than twenty years in age (in order to eliminate the necessity of introducing legislation for transfer as required by the Byrd Amendment, and thus expedite the acquisition) were located in the Canal Zone and earmarked for MAP-CB. However, the ready availability of additional LCM-8's from U.S. Army assets at Okinawa resulted in a subsequent redesignation of three LCM-8's at Okinawa in lieu of the three in the Canal Zone. Activation work (including installation of stand-off blisters and foaming of hull and blisters of the three craft) commenced in March. The craft will now be inactivated and returned to USA assets.

(3) Four LCM-6's. These craft, located in San Diego and reportedly chosen on the basis of being in excess of 20 years in age, were shipped in March 1975 by opportune lift to Subic Bay for rehabilitation and transfer to MAP-CB. Acquisition efforts have been terminated and the craft will revert to USN assets in place.

d. A total of eight LCM-6 and LCM-3 craft at Subic Bay were identified for transfer to MAP-CB under MIMEX. Included in the FY75 MAP-CB Program were the conversions of four LCM-3/6 to Monitors. It was intended, therefore, to convert four of these eight MIMEX craft to Monitors and rehabilitate the

[REDACTED] [REDACTED]

[REDACTED] [REDACTED]

remainder as LCM-6's or 3's. With the establishment of the \$200M NOA ceiling for MAP-CB, the funding of Monitor conversions was deferred. There were no known expenditures recorded for industrial work on these eight craft which will revert to USN assets.

e. The loan of one floating crane (YD) and one medium harbor tug (YTM) was requested by the GKR. YTM-764 and YD-154 on the west coast of CONUS were selected. The YTM-764 was earmarked for service in the Phnom Penh area and the YD-154 for service at Ream. Both craft were scheduled to be towed to SRF Subic Bay for rehabilitation in May, but all acquisition actions have been cancelled.

[REDACTED] [REDACTED]

[REDACTED] [REDACTED]

5. MATERIAL, MAINTENANCE, AND SUPPLY.

a. MNK Industrial Capability. MNK had shipyard facilities at Chrui Chang War, near Phnom Penh, for riverine forces and at Ream for maritime forces. The former was capable of most topside and underwater repairs for craft up to the size of LCM-8's. The latter was able to accomplish topside and underwater repairs on all craft except for the four ocean-going patrol craft.

(1) The Chrui Chang War facility included all shop facilities required for riverine craft repairs, but was limited in future expansion by shop space and electric power limitations. Major shop limitations also included: limited sources for gases (acetylene and oxygen) which were obtained commercially, near-absence of ordnance repair equipment, and inadequate numbers of engine repair and test stands. Craft lift capability included a vintage 350-ton capacity floating drydock, a 60-ton capacity floating crane (limited in practice to lifts not exceeding 30 tons), and a mobile crane capable of lifting and transporting PBR's. As of 1 April 1975, the total number of men engaged in production type work was 760. In March 1975, the floating crane and various shop equipments had been relocated to a safer site on the Tonle Sap River due to the increased rocket/mortar harassment at Chrui Chang War.

(2) The repair facility at Ream was one-third to one-half the size of that at Chrui Chang War. Included with the Ream facility was a 1000-ton capacity floating drydock (ex-AFDL-11) on loan from the United States. The Ream facility was capable of intermediate level maintenance on Maritime Region craft, which included PER's, LCM-6, LCU, PCF and four 32-year-old patrol craft (PC).

(3) Skill levels of personnel at repair facilities were adequate in the basic trades (welding, machinist, carpentry and electrical) but were deficient in trades requiring extensive training (electronics, gyro compass repairs, hydraulics and ordnance). The facility at Chrui Chang War encountered considerable difficulties in LCM-8 clutch repairs, repairs to 105mm turret components, and tug engines. The Ream facility had chronic difficulties with gyro compasses, fathometers and radars. In addition, many of the internal systems of the four patrol craft were inoperative or marginally operative, as parts were especially difficult to obtain for aged machinery components. The nineteen PCF's were operational more than 90% of the time despite hull construction deficiencies which were slowly being corrected by the Khmers.

(4) Two mobile support bases (MSB) were used by MNK, one at Neak Loeung and the other at Chrui Chang War. These bases consisted of four connected barges and provided capabilities for PER repair and for fueling and limited logistics support. Their capability for repairs to other craft types was extremely limited.

b. Riverine Craft Protection. This program was comprised of the several separate projects described below:

[REDACTED] [REDACTED]



[REDACTED] [REDACTED]

(1) Foaming and blistering work was the most significant project in the program and involved (a) installation of three-foot-wide standoff blisters and (b) buoyant foam in hull and blister voids. The blisters consisted of one cubic yard frames constructed of 10 pound angle iron bounded by sheet metal on horizontal and vertical surfaces, the latter also being covered on the exterior by chain link fencing, and foam in the interior. The combination of fencing and vertical sheetmetal surfaces was intended to provide standoff protection by pretriggering shaped charge projectiles to minimize damage within the interiors of the craft. The foam was intended to inhibit progressive flooding and to serve as a "life jacket" for the craft. Visual examination of several blistered craft hit by shaped charge projectiles showed that the blister design was usually effective in pretriggering. However, these measures were intended primarily for protection of the craft itself rather than protection of the cargo. The following is a table of riverine LCM-6's showing losses among craft foamed and blistered, foamed only, and unmodified:

	<u>Total</u> <u>Number</u>	<u>Losses As Of</u> <u>12 APR 75</u>	<u>Remaining As Of</u> <u>12 APR 75</u>
LCM-6's foamed and blistered	12	5	7
LCM-6's foamed only	3	3	0
LCM-6 unmodified	5	3	2

All losses among foamed and blistered LCM-6's are known or suspected to have been the result of exploding or burning cargo. Nevertheless, foamed and blistered LCM-6's had significantly greater survivability than those without. Three LCM-8's were foamed and blistered and there were ongoing plans to install and foam blisters on 11 Monitors, 14 ATC's and all new acquisition LCM-8/6's.

(2) Damage control kits were assembled for 133 riverine craft, about half of which were PBR's and the remainder riverine assault and logistics craft. Kit contents included tools (e.g., cutters, hammers) and flooding arrestor (e.g., wooden plugs, rubber sheeting). In February 1975, kits were distributed, but there was no report of their actual use for their intended purpose.

(3) Salvage pumps and accessories were obtained in the late autumn 1974 and approximately 33 were installed aboard selected riverine assault and logistics craft in January 1975. There were reports of salvage operations using these pumps on at least three separate occasions and five pumps were damaged by enemy fire.

(4) Stand-off chain link fencing was installed on four minecraft to reduce hazards of shaped charge shore fire during minesweeping operations. The fencing was installed along the gunwales to protect the superstructure. There were no reports indicating the effectiveness of these installations; two of the four minecraft were lost after installation of the fencing, but these losses were reportedly due to mines.

[REDACTED] [REDACTED]

[REDACTED] [REDACTED]

(5) Installation of 20-pound plate longitudinal bulkheads in LCM-8 enginerooms and lazarettas was intended to (a) reduce probable flooding of engine rooms and (b) improve possibility of a craft having a take-home capability with one side of the engine room still operative in case of damage to the other. Actual installation was not accomplished due to the significant amount of industrial work required and the results of subsequent studies which showed the additional submergence (due to flooding) to be minimal.

c. The Khmer Navy Supply System.

(1) The Khmer Navy Supply System was made up of four stock points, located at major MNK maintenance sites. The central supply depot, at the Chrui Chang War Navy Base, carried approximately 18,000 line items of MAP-provided material plus some 1,000 line items of locally procured material of a consumable nature. Stocks at the central depot supported the Chrui Chang War maintenance facility and provided back-up support for the three other supply facilities. The second facility, at the Ream Navy Base, provided supply support to Maritime Region craft and the maintenance facility at Ream. This facility carried approximately 8,000 line items. The remaining two supply activities were located aboard the two Mobile Support Bases. MOBASE I, located at Chrui Chang War, was stocked with a spares load to support 20 PBR's. MOBASE II, at Neak Loeng, carried a spares load tailored to support PBR's, Monitors, and LCM's.

(2) The supply system operated on modified post-post procedures developed by MEDTC to fit the Khmer Navy's situation. The central depot was the primary receiving point for all MAP-furnished material. Material received at the central depot was either placed in stock for later distribution in accordance with requirements or immediately distributed to the customer on a direct-turnover basis. Material stocked at each facility throughout the system was recorded on standard Stock Record Cards and procedures were developed to enable routine stock replenishment of material carried. All Stock Record Card maintenance, replenishment computations, and requisition preparation was done by Khmer Navy personnel. MEDTC personnel monitored the system and maintained surveillance of performance. The system described above was the result of periodic refinement of procedures over the 1974-75 time frame. During this period simplified procedures for material issue, receipt, requisitioning, inventory control, and critical item management were developed and documented, and training sessions were held. These procedures emphasized sound, basic storekeeping principles and rapid material issue - with delivery direct to the customer in many cases. Success of the system is easily quantified: (a) Requisition fill rate from material stocked was 81 percent through mid-1974; as system improvements were initiated, this figure rose to 88 percent and held consistently in the 88-90 percent range through April 1975, (b) the number of craft down for parts consistently averaged 2-3 percent throughout the entire period. In short, the Khmer Navy Supply System was amply provided with spares and repair parts throughout the period and provided excellent supply support.

[REDACTED] [REDACTED]

[REDACTED] [REDACTED]

(3) Spares and repair parts were provided under follow-on support dollar lines. Requisitions for individual items were forwarded to the Navy International Logistics Command, Bayonne, N.J., where charges were logged accordingly against the appropriate line and supply action taken. The magnitude of follow-on support funding was as follows:

<u>LINE DESCRIPTION</u>	<u>FUNDED FY74</u>	<u>PROGRAMMED FY75</u>	<u>FUNDED FY75</u>
COMMUNICATIONS SPARE PARTS	117,200	106,856	76,057
OTHER COMMUNICATION EQUIPMENT	17,600	24,376	12,313
PRIMARY BATTERIES	37,500	67,000	50,100
BOOKS MAPS AND PUES	3,000	3,000	2,000
SHIPS SPARE PARTS	2,277,000	1,943,977	1,223,193
WEAPONS SPARE PARTS	36,500	85,200	50,860
NAVAL ORDNANCE SPARE PARTS	45,400	55,400	36,620
CLOTHING, TEXTILES ETC.	54,000	175,826	27,425
INDUSTRIAL SUPPLIES	115,500	124,650	104,395
OTHER POL	18,000	24,930	12,479
AUTOMOTIVE SPARE PARTS	77,000	129,600	68,880
OTHER SUPPORT EQUIP	37,750	25,000	25,000
TOTAL	2,836,450	2,765,815	466,129

It should be noted, however, that much of the FY75 funding was eventually diverted, during the February-April 1975 period, to augmented airlift and airdrop requirements.

(4) Since early 1974, MEDTC had engaged in a series of projects designed to upgrade significantly the facilities and operations of the Khmer Navy supply system. The objective of these improvements was to develop and foster self-sufficiency within the Khmer Navy. The most important of these projects are described below:

(a) Development of simplified procedures for material issue, receipt, requisitioning, inventory control, and critical item management. Layers of paperwork and approval requirements were removed when these procedures were implemented. The system described in paragraphs 3C(1) and 3C(2) above is the result of this project.

[REDACTED] [REDACTED]

[REDACTED] [REDACTED]

(b) Improved ammunition storage facilities. New, expanded, and safe storage facilities were built at Chruai Chang War (12,000 sq ft), Neak Loeng (4,000 sq ft), and Ream (4,000 sq ft). Previous sites were crowded and unsafe. The new facilities provided safe storage and resulted in marked improvements in the practice of ammunition control and inventory management procedures.

(c) Improved POL storage facilities. A bermed facility (4,000 sq ft) was constructed at Chruai Chang War for storage of drummed product. An adjacent pad was built for use as a local issue point that could be controlled to reduce pilferage.

(d) Increased repair parts storage capacity at the main supply depot, Chruai Chang War. This project, completed in December 1974, moved bulk paint, bottled gas products, and many large items from prime warehouse space into a paint locker and outside storage area converted from two old ammunition bunkers. The outside storage area was fenced for security and covered, an existing roof over the old bunker having been raised some 5 feet and extended over the entire area. The movement of this stock from the warehouse to more appropriate storage enabled the transfer of various types of ships' material to the main warehouse from a remote site and the dispersal of stock from previously over-crowded lines.

(e) Customer Support Center. This center, constructed to facilitate the simplified operating procedures described above, housed the requisition reception, technical, and locator functions and enabled the rapid processing of the requirement for issue to the customer prior to accomplishing the time-consuming stock control paperwork.

(5) Soon after the commencement of the 1975 Dry Season offensive, the Navy Division began to order repair parts on high priority requisitions based on anticipated needs of the Khmer Navy. Because of the tempo of operations, it was clearly evident that engine parts, weapons parts, and material for structural repair would have to be readily available to minimize craft down-time. To handle the initial surge, in view of the length of the pipeline, contact was made with Naval Supply Depot Subic Bay and DAO Saigon and arrangements were made to obtain minimum quantities of critical material not already in stock. These were obtained, flown in, and replacements ordered for delivery to the appropriate supplying activity. Concurrently, NAVILCO was advised of MEDTC's intention to order on an anticipated Not Operationally Ready Supply (NORS) basis and agreed to process requisitions accordingly. In addition, in order to further reduce NORS time, 24 spare 6V-71 engines (used on LCM-6's, LCM-8's and other craft types) were obtained so that an engine pool could be established. In this manner, an engine needing repair could be removed and a new/repared one immediately installed. The inoperative engine could then be inducted for overhaul and repair. Also, quantities of armor plate, bumper half pipe, angle iron, and sheet metal were obtained from SRF Subic to be available for structural repair. A portion of the armor plate was cut by SRF into patch-size pieces as specified by MNK. Concurrent with the above actions,

[REDACTED] [REDACTED]



material arriving by surface at Sattahip, Thailand was screened and called forward by air to build up in-country stocks of critical items. All echelons and activities of the U.S. supply system involved were most responsive, helpful, and cooperative. Requirements received priority attention and were processed most expeditiously.



SECRET

[REDACTED] [REDACTED]

6. TRAINING. Khmer Navy strength increased from approximately 5,600 in November 1972, to a maximum strength of 15,758 on 30 November 1974. A large portion of the increase in authorized strength was to fill the existing BFM's and to form additional battalions for convoy protection on the banks of the Mekong and the Tonle Sap Rivers, extending from the Vietnamese border to the provincial capital of Kompong Chhnang.

a. In-country Training. In-country training of Khmer Navy personnel was accomplished at the Enlisted Training Center and at the Officers Training School at the Naval Base at Chruai Chang War. This was supplemented by practical training aboard Khmer Naval craft at riverine and maritime bases. Training was divided into four categories:

(1) Brevet Supérieur (B.S.) - Advance training - five months in length.

(2) d'Admissibilité au grade de second Maître (CA/SM) - Petty Officer training - three months in length.

(3) Brevet Élémentaire (B.E.) - Basic training - two months in length.

(4) EOM-Promotion - Officer Candidate training - six months in length. Subparagraphs (1), (2) and (3) above were enlisted training.

The curriculum for each course was planned prior to convening time and approved via the chain of command by all Bureau Chiefs and the CNO. Language presented, a major difficulty in the training centers. All MAP-furnished equipment was provided with English instruction manuals. Since MAP funds could not be utilized to translate publications, students returning from CONUS courses were required to translate course information from English to Khmer. Many French publications were also utilized as reference material. All enlisted courses were taught in Khmer. Some officer courses were taught in French, but the majority were taught in Khmer. When the Dry Season offensive started in January 1975, the training center at Chruai Chang War received increasing amounts of incoming fire. Although reports continued to reflect many students in training status, by mid-February the classrooms in the training centers were empty, the students' being utilized for base defense, emergency maintenance, and manning of boats. Appendix 2 is a listing of all in-country training completed during FY74 and FY75.

b. Out-of-country Training. Out-of-country training of Khmer Navy personnel was accomplished in the United States and in the Republic of the Philippines. The CONUS training program was tailored to provide a cadre of instructors in the technical specialties required for the maintenance and operation of the riverine and maritime craft assigned to MNK, as well as to increase the leadership and management base of the rapidly expanding naval force. Personnel returning from CONUS training were utilized in the training center and in work centers. In the training center, returning personnel were utilized as instructors. In work centers, returning personnel were normally assigned as work center supervisors and could be seen as leaders and on-the-job trainers of individual groups. Appendix 3 is a listing of courses Khmer Naval personnel attended in CONUS. Appendix 4 is a listing of on-the-job training conducted at Subic Bay for Khmer Naval personnel.

[REDACTED] [REDACTED]

[REDACTED] [REDACTED]

c. Special Operations. With the closure of the Mekong, MNK decided to establish a Special Operations Force (approximately fifty men) to conduct interdiction operations against KC positions on the Mekong. This force consisted of better qualified individuals selected from MNK assets (i.e., SEALs, EFMs, etc). This group was to be trained at Ream Naval Base, and then committed to combat operations in a phased schedule. An instructor group was selected and a Program of Instruction developed for the training period. The instructor group set up the training at Ream during the period 24-30 March 1975. The main group of Special Operations personnel arrived on 31 March to commence the training period scheduled through the 15th of April. During this time, emphasis was placed on marksmanship training (M16A1, M79), scouting and patrolling techniques, and the essential requirements for the conduct of combat and reconnaissance patrols. The major thrust was toward practical application and night training. Unfortunately, this special training program was terminated by the rapidly deteriorating tactical situation country-wide.

[REDACTED] [REDACTED]

APPENDIX 1 TO ANNEX C

SUMMARY OF MNK CRAFT LOSSES PRIOR 12 APRIL 1975

<u>YEAR</u>	<u>PBR</u>	<u>LCM-6</u>	<u>LCM-8</u>	<u>MONITOR</u>	<u>MSM/R</u>	<u>ATC</u>	<u>OTHER</u>	<u>TOTAL</u>
1970	0	3	0	1	0	0	0	3
1971	0	1	0	1	0	0	0	2
1972	1	1	0	0	00	0	0	2
1973	1	0	2	0	1	1	0	5
1974	4	4	2	2	0	2	1 (PCF)	15
1975	18	11	1	4	2	7	*2 (MSR)	45
	—	—	—	—	—	—	—	—
TOTAL	24	20	5	7	3	10	3	72

\*PLUS MOBILE SUPPORT BASE II AT NEAK LOEUNG



IN-COUNTRY KHMER NAVY TRAINING

<u>TYPE OF COURSE</u>	<u>TRAINING COMPLETED</u>	
	<u>NUMBER OF STUDENTS</u>	
	<u>FY74</u>	<u>FY75</u>
OFFICER CANDIDATE SCHOOL	109	
RECRUIT	9439	460
<u>SPECIALIST:</u>		
QUARTERMASTER (MANOEUVRIER)	189	140
HELMSMAN (TIMONIER)	79	62
RADIO TELEGRAPH (TELEGRAPHISTS)	66	36
GUNNERSMATE REPAIR (ARMURIER)	34	22
GUNNERSMATE (CANONNIER)	143	122
RIFLEMAN (FUSILIER)	369	308
ENGINEMAN (MECHANICIEN)	270	224
ELECTRICIAN (ELECTRICIEN)	132	87
SUPPLY (FOURIER)	19	30
YEOMAN (SECRETAIRE)	14	24
STEWARD (MAITRE D'HOTEL)		5
COOK (CUISINIER)		7

CONUS KHMER NAVY TRAINING

<u>TYPE OF COURSE</u>	<u>WEEKS DURATION</u>	<u>NUMBER OF STUDENTS</u>	
		<u>FY74</u>	<u>FY75</u>
<u>OFFICER TRAINING</u>			
NAVAL WAR COLLEGE			
COMMAND COURSE	47	1	1
STAFF COURSE	23	1	1
NAVAL POST GRADUATE SCHOOL			
ENGINEERING ELECTRONICS	117	2	2
NAVAL ENGINEERING/MECHANICS	117	1	1
SUPPLY MANAGEMENT	8	1	
FUNCTIONAL SUPPLY	14	3	5
INTELLIGENCE	8	2	2
OJT/LANDING PARTY/RIVERINE WARFARE	8	19	10
OJT/USMC/RIVERINE OPERATIONS	29	10	15
SHIP SALVAGE DIVISION OFFICER	16	2	2
CEC OFFICER BASIC QUALIFICATIONS	8	1	1
NAVAL SHIPYARD PROCEDURES/OPS	12	2	1
HARBOR DEFENSE	10	8	4
IOCS	33	20	
ENGINEERING OFF SPECIAL COURSE	40		8

CONUS KHMER NAVY TRAINING

<u>TYPE OF COURSE</u>	<u>WEEKS DURATION</u>	<u>NUMBER OF STUDENTS</u>	
		<u>FY74</u>	<u>FY75</u>
<u>ENLISTED TRAINING</u>			
E&E/RADAR/INST	52	7	4
E&E/COMMUNICATIONS/INST	47	7	4
E&E/INTERIOR COMMUNICATIONS/GYRO	30	4	2
E&E/GUNNERSMATE	20	2	6
RADIOMAN (TELETYPE MAINTENANCE)	20	-	2
AIR CONDITIONING/REFRIGERATION	8	3	2
MACHINIST MATE (CLASS A)	11	2	6
MACHINERY REPAIRMAN (CLASS A)	12	3	6
(CLASS B)	12	3	6
HULL TECHNICIAN	19	4	2
ENGINEMAN (DIESEL) INST	19	7	8
OPTICALMAN	17	-	1
INSTRUMENTMAN	17	-	2
STOREKEEPER (INDEPENDENT DUTY)	13	-	10
UDT	25	4	2
LANGUAGE INST	24	4	5
LANGUAGE LAB MAINT OUT	16	-	2
HARBOR DEFENSE	10	2	6

[REDACTED] [REDACTED]  
APPENDIX 4 TO ANNEX C

TRAINING IN THE REPUBLIC OF THE PHILIPPINES

<u>COURSE</u>	<u>DURATION IN WEEKS</u>	<u>NUMBER OF STUDENTS</u>
DIESEL ENGINE REPAIR	6	25
ORDNANCE REPAIR	6	17
PIPE FITTING	6	9
SEAL TRAINING	10	23
ALUMINUM WELDING	6	6
FIBER GLASS REPAIR	6	11
AIR CONDITION AND REFRIGERATION	6	4
ELECTRIC MOTOR REPAIR	6	6
GYRO COMPASS REPAIR	6	4
FOUNDRY AND MOLDER	6	5

[REDACTED] [REDACTED]

[REDACTED]

ANNEX D

[REDACTED]

## AIR FORCE

### 1. AIR FORCE DIVISION.

a. Organization and Functions. Until August 1974 MEDTC was organized along functional lines, with tri-service manning of the Plans and Programs, Logistics, and Management Assurance (including training) Divisions. During this period, a separate Air Force entity was represented by the CHIAD Team (Chief Inspection and Analysis Division), which had been formed and attached to the U.S. Mission in the Khmer Republic under the Tactical Air Improvement Plan-Cambodia (TAIP-C). The continual reduction in program funds and the need to monitor more closely the utilization of items on hand by service elements contributed to a decision to reorganize MEDTC along service lines.

In August 1974, MEDTC was reorganized and the Air Force Division formed. In a switch of emphasis from logistics and programs to utilization of what equipment existed or was already in the pipeline, the Division was more operationally oriented on the CHIAD model. The new Air Force Division organization chart emphasized rated positions, but, in the transition, personnel from the previous MEDTC organization, some of whom were not rated, were integrated into the new positions. This produced an awkward situation in which assigned personnel did not fit Joint Table of Distribution Air Force specialty codes but adjusted into roles as the situation required. During this period of transition, five Air Force personnel with special operations experience in SE Asia were assigned TDY. During a one-month period in February 1975, four new officers arrived on permanent assignment, releasing the five officers on TDY, including the Division Chief, and leaving the division with little continuity in the area of operations analysis.

Personnel of the USMACTHAI Directorate of Training and Logistics (DTL), an Air Force support organization in Bangkok which interfaced with Thai Am for aircraft maintenance and Udorn for training, were used liberally, to the limit of headspace restrictions, in a TDY role to flesh out and generally supplement the Air Force Division. When the AF logistics chief retired unexpectedly for health reasons, for instance, two officers from MACTHAI DTL filled in to provide continuity until a new logistics officer could be assigned.

[REDACTED]

[REDACTED]

TABLE 1. AIR FORCE DIVISION MANNING TABLE  
AUG 74 to APR 75\*

<u>Title</u>	<u>AFSC</u>	<u>Grade</u>
Chief Air Force Division	E0036	O6
Admin Supv	70250	E5
Chief Plans, Training and Analysis Branch	0036	O5
Training Officer	1495Z	O4
Operations Analyst	1495Z	O4
Operations Analyst	1495Z	O4
Operations Analyst	1495Z	O3
Chief Logistics Branch	6616	O5
Maintenance Officer	4016	O3
Maintenance Supervisor	43191	E9
Supply NCO	64570	E7
Programmer	64590	E8

OFF 8

EM 4

\*JTD/MEDTC, 1 OCT 74

TOT 12

b. Relations with Other Organizations. Most members of the Air Force Division were in daily contact with their Khmer Air Force (KAF) counterparts, generally at Hq KAF or at Pochentong AB. Visits to outlying bases were much less frequent and, after January 1975, they were discouraged because of the deteriorating tactical situation. Many KAF officers spoke adequate English, and there were enough French-speaking officers in the Air Force Division to interpret for those who did not. Several officers of the Division took Khmer language lessons and became conversationally proficient. The barrier to communications was not so much language as it was the erratic work hours of some Khmer middle management which made it difficult and frequently frustrating to locate key personnel. One attempt to circumvent this problem was the institution of a formal weekly meeting between the Chief of Staff of the Khmer Air Force, his principal staff members, and the Chief and various members of the Air Force Division. This routine encounter, with a formal agenda coordinated a week in advance, worked fairly well from September 1974 through December 1974, but the meetings were suspended at the onset of the January 1975 offensive and were never reinstated. During this period, Brig Gen Ea Chhong, Chief of Staff of the Khmer Air Force, improved steadily in his grasp of English, and, by the last three months, he was conversing satisfactorily in English with the Chief of the Air Force Division. Daily conferences between these two officers more than made up for the lapse of the weekly meeting.

[REDACTED] [REDACTED]

There was similar close association between the KAF and other members of the Division. The training officer made daily trips to Hq KAF to coordinate face-to-face with his principal counterparts. The Maintenance NCO's routine place of business was at Pochentong AB, with either the KAF maintenance activity or with members of the Logistics Management Assistance Team (LMAT) contract organization. This NCO inspected maintenance practices and facilities, helped coordinate ferry movements to and from Thai-Am Bangkok, and reported on maintenance status and problems to the Chief of the Logistics Branch.

The Division operations analysts were principally responsible for Division End-Item-Utilization Inspections (EIUIs). Initially, EIUIs were oriented almost exclusively toward tail number inspections of individual aircraft on a scheduled basis. Later, the tendency was to de-emphasize hardware, and EIUIs reported on KAF bases, overall organizations, command-and-control relationships, etc. The operations analysts kept in very close contact with personnel of the Ammunition and Services Division, overseeing ammunition stocks and calls forward. Particularly towards the end, the analysts closely monitored munitions and fuel stocks, especially the proper mix of munitions, so that the KAF could operate more effectively within fund limitations. The analysts also made frequent visits to the Direct Air Control Center (DASC) at the Etat Major General (EMG), the Air Operations Control Center (AOCC) at KAF Headquarters, and the Tactical Units Operation Center and the various squadrons at Pochentong Air Base.

Representatives of Air Force Division also had daily contact with the Officer-In-Charge of Construction, Cambodia (OICC), and the KAF and Pochentong Civil Engineering functions. Initially the Division was involved in the planning and programming of new construction, but, after January 1975, the concern was with damage control, passive defense, and facilities to accommodate the off-loading of DC-8/C-130 aircraft. The latter actions were necessary because the weight of these aircraft led to premature failure of a soil cement taxiway and apron.

All MAP-OR transportation was the responsibility of the Ammunition and Services Division, and the Air Force Division had no direct control or responsibility for the Bird Air C-130 contract or for the USAID airlift contracts. Air Force units outside MEBFC supplied a USAF Combat Control Team (renamed Cargo Control Team), USAF materials handling equipment repairmen, and an Air Force medic to help with the mission at Pochentong. But the Air Force Division was involved in several ancillary problem areas, such as coordination for air and ground control, taxi route prior-

[REDACTED] [REDACTED]

[REDACTED] [REDACTED]

### 3. KHMER AIR FORCE

#### a. Organization and Personnel

The KAF was organized as a small but separate service, with the Air Force Commander reporting directly to the FANK Commander-in-Chief. KAF Headquarters reflected both American and French influences in staff functions and suffered from an especially broad span of control (Chart A). Typically, the air base structure reflected a cleaner organization in appearance (Chart B), but unfortunately it was not so direct in actual operations. Complicating factors are discussed below in the maintenance, supply, and operations sections.

The force structure of the Khmer Air Force was originally programmed for a counter-insurgency mission in an emerging country, and this force objective had been reached by September 1974 (see tables 2 and 3). In conjunction with a SECDEF-directed plan to make the Khmer Air Force self-sufficient for in-country airlift, six additional C-123's arrived between December 1974 and March 1975. These additional C-123 aircraft were used to replace losses and to train additional crews and maintenance personnel in Thailand. They did not make any appreciable airlift contributions prior to the U.S. evacuation.

KAF never had a personnel recruiting problem. The total KAF authorized strength was 10,000 and was officially reported as approximately 9,800 by KAF. This total is somewhat misleading because it contains 7,500 to 8,000 personnel of Unités de Défense, i.e., battalions of the Regiment des Fusiliers de l'Air. These units were responsible for defense of the base perimeters and were organized on the Army model, into battalions of 512 men each. The operational Air Force (i.e. aircrews, maintenance, and other support functions associated with the flying mission) numbered fewer than 2,000 persons, of whom a number were in a somewhat swollen KAF headquarters. In recognition of the relatively few KAF personnel directly involved in the effective air support, strike, and airlift missions, the US Ambassador sent a letter to Brig Gen Ea Chhong, KAF Commander, in February 1975 expressing his admiration for the KAF and commenting, in Churchill's words, that "never had so many owed so much to so few." All those familiar with the situation concurred that the observation was as applicable to the KAF as it had been to the RAF.

One of the most basic problems of the KAF, one that it shared with all the Khmer services, was the totally inadequate motivation, incentive, and salary system. Economics unquestionably contributed to diversion of resources, the selling of favors, services, and equipment, and other such

[REDACTED] [REDACTED]



ORGANIZATIONAL CHART- HQ KAF

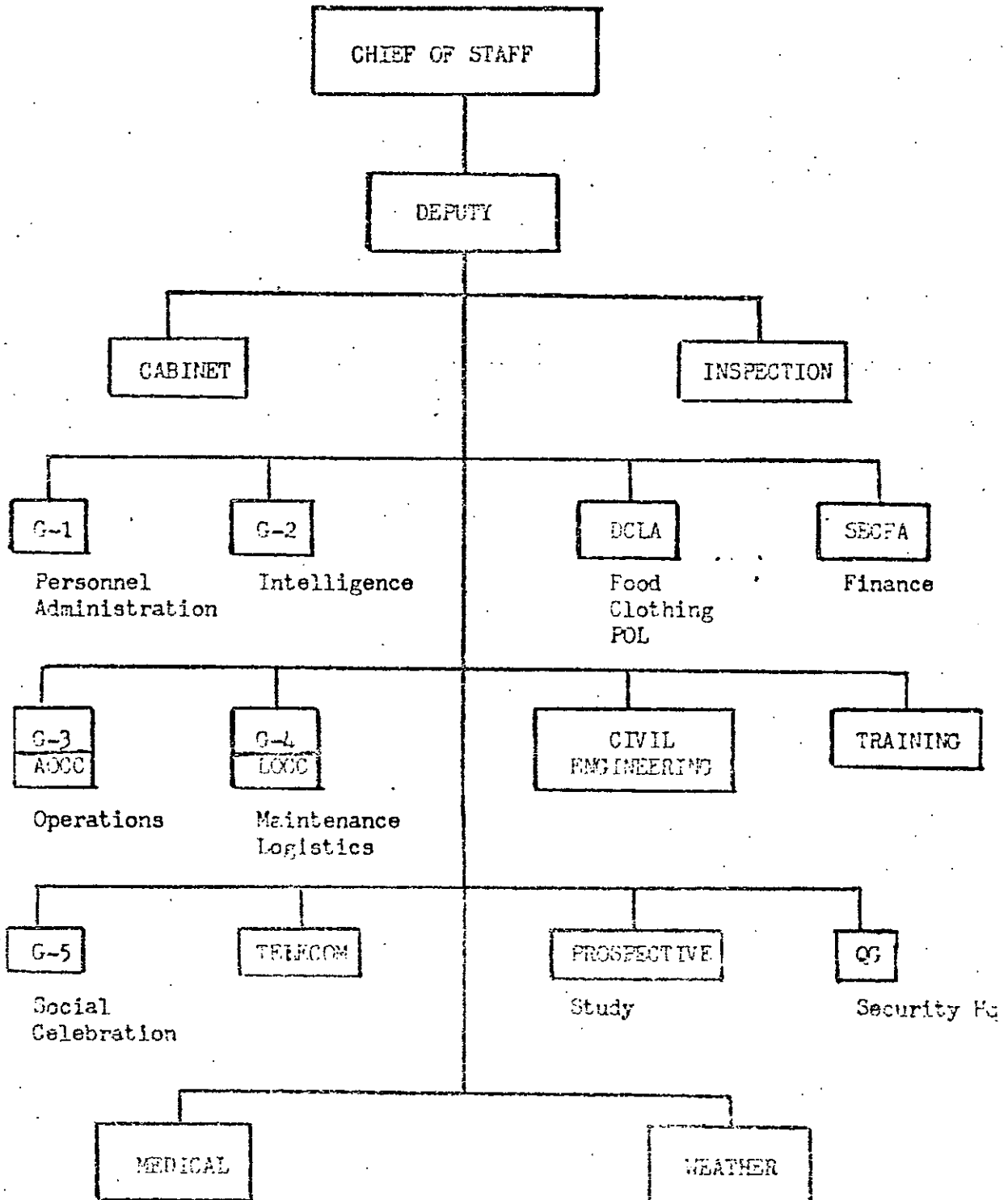

CHART A - HEADQUARTERS, KHMER AIR FORCE

TYPICAL BASS ORGANIZATIONAL CHART (POCHENTONG AB)

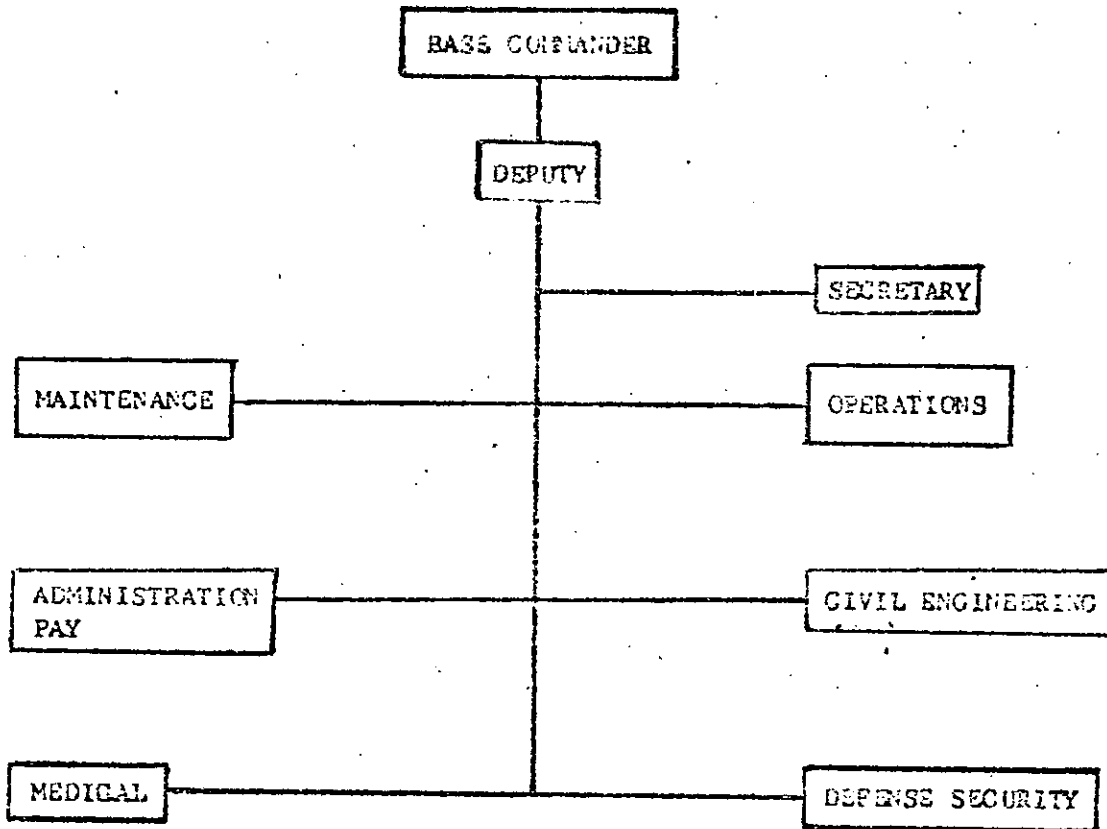

CHART B - TYPICAL ATR BASE ORGANIZATION

[REDACTED] [REDACTED]

corrupt KAF practices. The necessity to survive, along with the temptation of using official positions as a means to do so, inevitably led to falsified reports, evasion of responsibility, cynicism, theft, abuse of position, and lack of mutual trust and respect within and among the services. Military pay was a virtual insult; the monthly pay of even Lieutenant Colonels and Majors was hardly sufficient to keep them in cigarettes. As a consequence, an official role was often only a front for the real means of livelihood, and performance of military missions in many cases took second place to the requirement to make a living. Graft in the Khmer Air Force took a variety of forms, ranging from confirmed sales of transportation and profiting from unofficial cargo to allegations of KAF pilots' demanding pay-offs for providing fire support.

KAF was very thin in top-and middle-management leadership. Khmer society, oligarchical by tradition, did not have the inclination to adjust to a situation in which it was essential to train subordinates for upward mobility or for sharing of responsibility. The Americans, particularly technical representatives, quickly identified the few strong, effective leaders and worked through them to achieve objectives. The phenomena of separate formal and informal chains of organization and command, which exist in all elements of society, were particularly prevalent in the Khmer Air Force. The effective, energetic performers among the staff could be counted on the fingers of one hand. The others ranged from simple mediocrities who could perform, given enough time, to a vast majority who were deadwood.

Some of the most effective and most respected KAF leaders were Brig Gen Ea Chhong, Chief of Staff, Col Sok Sambaur, Commander of Pochentong AB, and Lt Col Tach Heng, Chief of the Groupment Technique de l'Air (The Pochentong Directorate of Maintenance). The latter unit, a monster organization of over 1,000 persons, included intermediate and organizational maintenance, munitions maintenance, the motor pool, aerospace ground equipment, and most directly related functions short of actual air operations or base defense and security.

Pochentong defense and security was the responsibility of Lt Col Koy Yon, another officer who became a U.S. favorite, who had previously been a finance officer. Because of his reputation for honesty, he was appointed to the Pochentong security responsibility by Brig Gen Ea Chhong in an attempt to curb some of the most blatant abuses of illicit transportation on military aircraft. Lt Col Koy Yon, an extremely intelligent and energetic officer who

[REDACTED] [REDACTED]

TABLE 2:

KAF AIRCRAFT STATUS AS OF 31 MARCH 1975

ACFT TYPE	PRO- GRAM- ED	RE- CEIVED	AS- SIGN- ED	LOST	AC OUT COUNTRY	AC IN COUNTRY	DAILY AVG OR RATE MAR
T-28D	76	76	58	18	18	40	66%
T-28B	16	16	15	1	13	2	100% *
T-41	23	23	13	10	0	13	85%
C-47	15	15	2	13	0	2	100% *
AC-47	17	17	14	3	2	12	58%
UH-1H	36	36	25	11	4	21	89%
O-1D	47	47	18	29	2	16	69%
O-1F	2	2	1	1	0	1	100% *
O-1G	8	8	5	0	6	2	100% *
U-1A	18	18	1	17	0	1	100% *
UH-1H(GUN)	15	15	14	1	1	13	85%
C-123K	20	20	17	3	5	12	55%
AU-24	15	15	13	2	1	12	82%

NOTE: The statistics for total aircraft possessed reflect the fact that at any given time, a considerable number of aircraft were out of Cambodia, either in maintenance at Thai-Am Bangkok, or supporting training programs at Udorn. \* 100% OR rate is misleading, because except for a few C-47 sorties, these aircraft were not flown during the month of March 1975.

[REDACTED] [REDACTED]

spoke excellent English, assumed responsibility for defense and security, trained and rejuvenated his unit, built additional defensive positions, lighted, fenced, and mined the perimeter, and became exceptionally forceful and effective. Col Sangwar De Lopez, Chief of Operations (G-3), was uneven in performance and peripheral to those who were utilized as effective points of contact by the U.S. personnel.

There were operational squadrons for each type of aircraft consisting entirely of rated personnel and a few administrative clerks. Some attempts were made to suggest changes in organization, but the lack of qualified personnel, the apparent resistance to giving up prerogatives or to assuming any additional responsibility, and the impossibility for US personnel to understand the underlying "squeeze relationships" involved, almost always made such reorganization initiatives fruitless.

It is not possible to verify, but it was believed that KAF did not have any sizeable number of phantoms (i.e., men listed on payrolls but not present for duty), although it would have been possible to conceal a number of them among the defense units who worked on shifts or among personnel at outlying bases.

TABLE 3. KAF PILOT STATUS AS OF MARCH 1975

AIR-CRAFT	FIRST PILOT/ FLIGHT LEAD	CO-PILOT/ WING MAN	NON-FLY DUTY	TRNG IN COUNTRY	TRNG OUT COUNTRY
T-28	27	30	0	0	19
AU-24	15	9	0	4	2
UH-1	35	30	26	16	0
C/AC-47	23*	34	0	0	6
O-1	21	0	0	0	14
C-123	8*	10**	5	4	26
Qualified Pilots				255	
Training in country				24	
Training out country				61	
Total				340	

\* Dual qualified C-47/C-123 First Pilot: 8.  
 \*\* Dual qualified C-47 First Pilot/C-123 Co-pilot: 10.

[REDACTED] [REDACTED]

[REDACTED] [REDACTED]

During 1974-75, the Khmer Republic was actually a series of enclaves, with air transportation often the only link between them. Some areas had food surpluses (Battambang, rice and sugar; Kompong Som, fish and salt) that were in very short supply in other areas (such as the capital). Therefore, there was a strong temptation to utilize any airlift space for such cargo. In the latter part of 1974, transportation of illicit cargo by all types of aircraft had reached epidemic proportions. During the Wet Season lull, the abuses did not significantly impact on combat operations; however, overloading had reached the point where aircraft and crews were jeopardized, and poorly packed commodities, such as sugar and even salt, were producing extra maintenance problems from spillage. Overloading contributed to several documented instances of damaged landing gears, and two major accidents were allegedly the direct result of overloading.

After AF Division Chief's direct criticism and strong letters to the KAF Commander produced no noticeable improvement, on 18 October 1974, the Chief, MEDTC, sent a letter on the aircraft abuse to Lt Gen Sosthene Fernandez, Commander-in-Chief of FANK. Within a few days, Brig Gen Ea Chhong called a meeting of all base commanders and requested that the AF Division Chief and the US Air Attache attend. The AF Division Chief presented the US position regarding flying safety and illicit use of planes and General Ea Chhong endorsed these views. Brig Gen Pao Lim Sina, the KAF Deputy Commander, and Col Khuen Frang, the Pochentong Deputy Commander, who were allegedly the two worst offenders, were sent on an extended TDY. From that time on, cargo in non-transport aircraft and obvious abuses diminished markedly. It was also at this time that Lt Col Koy Yon (previously mentioned) was appointed Chief of Defense and Security at Pochentong.

(1) Airfields.

Pochentong Air Base, on the southeast side of the runway which it shared with Pochentong International Airport, was the center of over 90 percent of all KAF operations, maintenance, and logistics. There were also two other bases with hard-surfaced runways, one at Ream, near Kompong Som on the southern coast, and the other at Battambang in the Central Northwest. At Battambang, KAF conducted rudimentary T-41 training and had plans to develop a T-28 training capability, but these plans were not implemented before the US Mission's evacuation. There were also KAF bases at Kompong Cham and Kompong Chhnang with improved runway surfaces. Usually two or three T-28's, an O-1D, an AC-47,

[REDACTED] [REDACTED]

[REDACTED] [REDACTED]

or an AU-24 were stationed on these outlying bases. In addition, until the small runway came under direct fire, O-1D's and helicopters operated from Neak Leoung on the Mekong River. Plans to upgrade facilities at the outlying fields and to disperse KAF operations and maintenance throughout the country were constantly overcome by events and were never realized.

## (2) Facilities.

The Pochentong runway was more than adequate for KAF operations, but it developed significant cracks shortly after the introduction of continuous and frequent DC-8 traffic. In 1973, the Officer-In-Charge of Construction (OICC) developed a comprehensive, long-range plan for repair and construction of aprons and taxiways at Pochentong. The plan was developed with a committee composed of representatives of the US Embassy, USAID, the Government of the Khmer Republic, and MEDTC, and the plan was funded in 1974. However, with the enemy occupying the only available sources of crushed rock in-country, destruction of the only cement plant, and reduction in river traffic in the fall of 1974, it was almost impossible to obtain construction materials in quantity.

With crushed rock and cement not available, the committee agreed to proceed with soil cement construction for the new aprons, one each on the military and civilian sides of the base. This option permitted an interim solution and provided the substructure on which a permanent concrete surface could later be laid. Construction of the new civilian ramp north of the runway and the Charlie ramp south of the runway was completed in November 1974. Without a permanent surface, the soil cement could not be expected to last more than one or two rainy seasons. By mid-April 1975, the surface of the Charlie ramp was beginning to show signs of deterioration as a result of the heavy DC-8 traffic of the augmented airlift. It is questionable whether this soil cement area could have lasted as a usable surface for DC-8s for more than a few weeks longer.

Resurfacing of the KAF maintenance area faced the same difficulty of lack of materials, plus the problems of working around active operations and the lack of necessary equipment for tearing out large areas of old concrete where slabs had heaved and cracked from age and from poor substructure. As a result, the work on the military ramp, foreseen as one of the top priorities at the time the comprehensive plan was drawn up, was never accomplished. By the time of US evacuation, the accelerating deterioration of both concrete and pierced steel planking (PSP) portions of the KAF maintenance and operations parking area had

[REDACTED] [REDACTED]

[REDACTED] [REDACTED]

and the other bases, these funds were repeatedly reprogrammed into ammunition lines because of funding limitations. As a result, KAF shops, warehouses, and supply activities were still in the pre-World War II structures of the old military base or in corners of existing hangars, walled off with temporary partitions. Some shops, such as those for airborne radio repair and engine build-up, were housed in adequate facilities, until the buildings received repeated direct hits by 107mm rockets in late March and April. For the most part, facilities were rudimentary, but it cannot be said that they were limiting factors in KAF effectiveness. All facilities would have required significant expansion and improvement in order for KAF to have gone much further towards in-country maintenance self-sufficiency.

#### b. Logistics

The KAF logistics system, which improved slowly but steadily, was generally capable of supporting the KAF flying mission. As the 1975 Dry Season Offensive progressed, the logistics functions kept pace with the increased flying missions and gave effective support until Pochentong Air Base became saturated with rocket attacks in March 1975. During the final month, many aircraft and facilities were damaged, many personnel were killed or wounded, overall morale deteriorated, and absenteeism increased until even logistics slowed considerably. Overall, the logistics effort was considered satisfactory, but there were many problems, often springing from complex religious, sociological, political, and economic forces in the Khmer society, which were difficult to define and solve.

Fragmentation of lines of responsibility contributed to many logistics problems. The organization, (Chart C), often a hybrid of French and U.S. systems, did not contribute to efficient management of materiel resources. Major supply functions such as depot supply, POL, armament, and telecommunications were under the direct control of KAF headquarters, instead of being decentralized at base level. In 1974, the materiel pool and the aerospace ground equipment section were removed from the headquarters, reorganized into the Aerospace Ground Equipment Support Squadron (AGESS), and placed under the control of the Group Technique de l'Air (roughly equivalent to a wing-level maintenance directorate). This organization greatly improved control, reaction time, and utilization of these resources in support of the mission. But, except for the AGESS, support agencies were not controlled by the base commander and consequently they were not always responsive to his requirements.

[REDACTED] [REDACTED]



[REDACTED] [REDACTED]

In addition, each materiel function at Pochentong was a separate entity with little coordination or support between functions. It appeared that each functional manager jealously guarded his own domain and resented anyone else's invading it. This independence also degraded requests for assistance from other lateral agencies, and almost prohibited a coordinated effort, except when specifically directed by the KAF Commander. Consequently, extensive bureaucratic, time-consuming procedures were involved in trying to get spare parts and other equipment. The same situation, only worse, was found when KAF requisitioned items from FANK, such as POL, ammunition, and other common-use items.

The physical plant at Pochentong Air Base was inadequate to support the number of aircraft assigned. In November 1972, KAF possessed only 86 aircraft; at the start of the 1975 offensive, KAF was supporting over 200 aircraft, with about half usually located in Pochentong. Even without the war, it would have been difficult to manage effectively such a large operation with antiquated and inadequate facilities. Compounding the problem was a shortage of experienced technicians and dedicated supervisors, a lack of discipline, inadequate control of personnel, and little concept of the overall force structure required to support the workload. Yet despite these deficiencies, the KAF logistical function continued to improve in its support of the mission.

Much of this improvement can be attributed to the Logistics Management Assistance Team (LMAT). This team provided a 47-man contract logistic system which helped develop the logistical management structure, scheduled the delivery of MAP materiel in consonance with KAF capabilities, and assisted the KAF towards attaining logistics self-sufficiency. The team consisted of 5 American technical representatives, 17 third-country nationals, and 25 local nationals. LMAT was an invaluable asset because of Congressional limitations on military advisors to the Khmer Republic. Without this small logistical support team, the KAF logistics system could not have accomplished its mission. A larger team could have been effectively utilized to extend support to the five KAF outstations.

#### (1) Maintenance.

The KAF maintenance organization was also a mixture of French and US systems. At Hq KAF, the overall logistics structure was controlled by the G-4, who was supported by the Logistics Operation Control Center (LOCC). All maintenance activities at base level worked for the base commander, even though the KAF G-4 was directly responsible for materiel support at all bases. These don't

[REDACTED] [REDACTED]

[REDACTED] [REDACTED]

reached serious proportions, so that through the last months, heavily loaded T-28's were required to taxi very carefully to avoid hitting a prop. Most of the PSP ramp and revetment area was rough and usable only for C-47's because of holes under the PSP formed during previous wet seasons.

The civil engineering efforts to keep Pochentong operational through the last months were increasingly assumed by the OICC Director of Construction for the Khmer Republic, with assistance from the MEDTC Air Force and Army Divisions when Khmer military engineers were required. Generally, the performance of the FANK engineers was prompt and efficient; that of the FANK EOD personnel desultory and generally ineffective. The AM-2 matting, installed to prevent failure of the soil-cement taxiway, required maintenance at night by the FANK engineers. Also at night, they repaired damage caused by artillery and rocket impacts and displacement of the matting by DC-8 jetwash.

The KAF civil engineers at Pochentong would respond to problems only after extensive prodding. The commander of the civil engineer squadron was difficult to locate after 1 January, and the civil engineer from Hq KAF was rarely seen at Pochentong.

Due to the unresponsiveness of KAF engineers, the OICC arranged a detail of local nationals to police up shrapnel from the runway and taxiways during the daytime and supervised a runway, taxiway, and apron repair contract for Pochentong. Both projects were moderately successful until mid-March when the rockets became more numerous and the workers walked off the job. As a replacement, and at the urging of the Air Force Division, the KAF engineers took on the task of policing shrapnel from the runway at night by having a crew walk behind a towed NF-2 light cart. This operation was very successful, but it could only be accomplished through the personal intervention of an Air Force Division observer who made all arrangements and accompanied the group. When the observer did not appear, there were always excuses as to why this simple job had not been done. A similar situation developed when arrangements were made to obtain a motor-driven, towed sweeper to clean runways and aprons. So far as is known, this operation was never carried out unless an Air Force Division observer was present.

Although for the previous two years, considerable construction of buildings had been programmed for Pochentong

[REDACTED] [REDACTED]

[REDACTED] [REDACTED]

lines of responsibility contributed significantly to delays and confusion.

Base-level maintenance organizations, similar to US maintenance activities, were centralized under a Director of Maintenance at all bases. While this was effective at Pochentong, it was inappropriate and ineffective at all other stations because of the small number of aircraft deployed. In addition, KAF maintenance at Pochentong was supported by the Logistics Management Assistance Team (LMAT). Almost all KAF maintenance and over 90% of all operations were conducted from Pochentong.

CHART C. KAF LOGISTICS ORGANIZATION

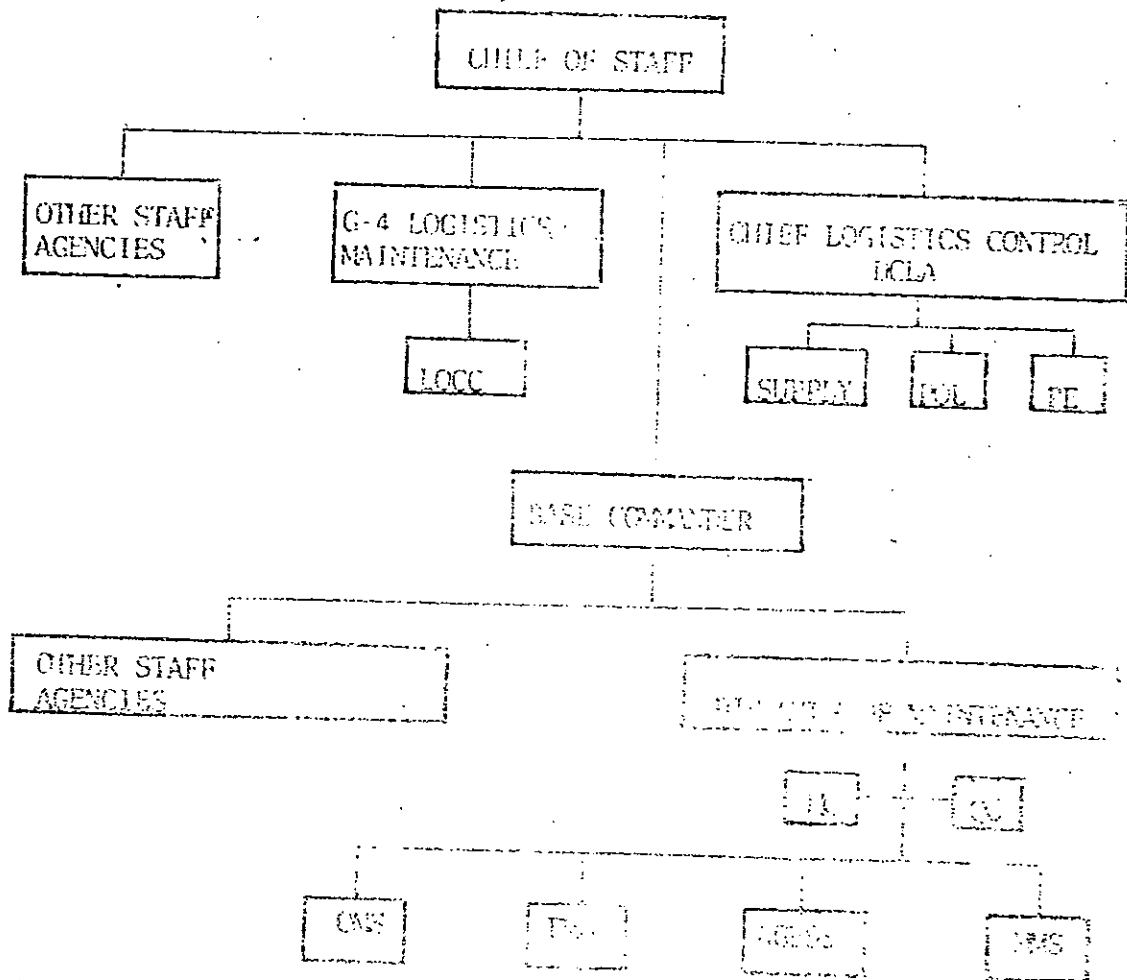

[REDACTED] [REDACTED]

At KAF headquarters, the G-4 personnel charged with the responsibility for maintenance support at all bases were ineffective. Aircraft at outstations were out-of-commission for prolonged periods because of lack of support from the headquarters. Messages sent to headquarters for parts or personnel were not handled quickly, and minor problems at all bases were compounded by the complexities of FANK and KAF organization.

The maintenance activity at Pochentong was organized along the lines of normal U.S. maintenance staff functions and organizations, with Maintenance Control, Quality Control, the Organizational Maintenance Squadron (OMS), the Field Maintenance Squadron (FMS), the Aerospace Ground Equipment Support Squadron (AGESS), and the Munitions Maintenance Squadron (MMS) all under the control of the Director of Maintenance. While the Director of Maintenance at Pochentong was a strong leader and was capable even by U.S. standards, he was supported by only two or three capable subordinates.

Of all staff agencies, Maintenance Control was the most effective, but by USAF criteria the unit would have been rated as marginal, primarily because it did little planning and scheduling. Communications was one of the biggest problems. Although handi-talkie radios were used between shops, maintenance control, and the flight line, status reporting was slow, and transportation was non-existent for maintenance personnel. The Material Control function was barely satisfactory primarily because the supply and maintenance functions were organized under separate lines of authority. Material Control's primary responsibility was to validate parts requirements and to prevent pilferage. It was not responsive to the urgency of combat operations.

Quality Control was also ineffective. There was no quality inspection program and safety practices were largely ignored. Technical publications were grossly mismanaged and not kept up to date. Periodic checks of tech data on order revealed unneeded tech orders such as "Desert Preservation of Aircraft" or tech orders for the F-4. The principal limiting factors within this function was the lack of qualified and adequately trained personnel and the lack of a strong program.

The Aerospace Ground Equipment Support Squadron (AGESS) was charged with the responsibility for both Vehicle Maintenance and AGE Maintenance. Working out of an inadequate facility, this squadron barely managed to keep enough equipment in-commission to support AGE requirements. Preventive maintenance was not performed; equipment was repaired only after it had broken down.

[REDACTED] [REDACTED]

[REDACTED] [REDACTED]

POL for AGE was rationed by higher headquarters, and in most instances the allocation was inadequate. Tech data and spare parts were difficult to obtain. Most AGE equipment was outdated, a mixture of various types and manufacture. Very few could be interchanged. Problems could have been reduced if common items had been supplied.

This squadron was also required to provide maintenance on 90 to 95% of all KAF vehicles. Problems with parts pilferage were extensive and contributed to a high out-of-commission rate. Once again the US vehicles were of different manufacturers, models, and years and caused many problems in supply support. Common-usage vehicles should have been supplied by the same manufacturer as much as possible. Ideally, local general purpose vehicles should have been supplied which could have been supported off the local economy.

The most arduous task required of the AGESS was the support of forklifts. In the period Nov 74 to Apr 75, an average of only 4 out of 42 forklifts were in commission each day, a condition which became extremely critical during the 1975 Dry Season Offensive. Major problems in this area were obsolescence and, again, the variety in types of equipment, the lack of tech data, difficulties in parts supply, and once again, a total absence of preventive maintenance.

The Field Maintenance Squadron shops performed well, as most personnel assigned were well-trained technicians. Facilities and equipment in most shops were adequate. The Engine Build-up shop was hampered by the lack of quick engine change kits on the R2800-99W and J85-17 engines and the lack of a forklift or overhead hoist for moving engines. In most instances, Field Maintenance supplied excellent support to the mission.

The Organization Maintenance Squadron (OMS) performance was continually improving. The UH-1H, AU-24, and O-1 sections performed first and second echelon maintenance locally. The C-47 and C-123K sections were also capable of performing maintenance at these levels, but these aircraft saturated the maintenance capability and 20% of phase inspections for the AC-47's and 60% of these for the C-123K were performed under contract at the THAI-AM facility in Bangkok. The T-28 maintenance section was well qualified; however, lack of heavy maintenance jigs caused Twelfth Phase inspections, the T-28 wing-strengthening tech order modification, and heavy crash/battle damage to be performed at the THAI-AM facility.

[REDACTED] [REDACTED]

[REDACTED] [REDACTED]

The number of mechanics assigned to the OMS at Pochentong was inadequate. Training programs had originally lagged behind aircraft deliveries, and there was a continual shortage of personnel at the higher staff levels. Manning at outstations was more than adequate for their OMS workload, however. Attempts to coordinate personnel shifts from the outstations to Pochentong to relieve the imbalance were frustrated at Hq KAF. Even though personnel shortages existed throughout the Dry Season Offensive, the OMS continued to support the increased sortie rate satisfactorily, until it was overloaded by extensive battle damage from rockets in late March and early April, when over fifty aircraft were damaged in less than three weeks.

Personnel of the Munitions Maintenance Squadron (MMS) did an excellent job in providing loaded aircraft. Although many improvements were made in munitions storage facilities at Pochentong, proper safety practices were seldom adhered to. On aircraft uploaded at night, the weapons were armed at time of loading. Cartridges were seldom removed from bomb racks. Make-shift transportation dollies were used to move weapons. Rocket pods were downloaded and taken to the shop and benchchecked without always removing the rockets--a practice which resulted in a rocket being fired through the roof of the armament shop on at least one occasion. Support of gun systems on all aircraft was marginal. Many problems existed because of non-availability of parts for the XM-197 and XM-93 gun systems. Maintenance by gunners on AC-47, .50 caliber machine guns was non-existent. Little pre-flight or post-flight armament systems maintenance was accomplished. The T-28 gun charging system also created a problem, and numerous sorties were flown without operative guns. As a result of MEDTC inspections in the munitions area, the Air Force Division called these discrepancies to the attention of Hq KAF in repeated letters. Normally the discrepancy would be corrected for a short time, but the unsafe practices would soon reappear, especially in the press of expediting munitions-handling during the last KC offensive.

While maintenance technicians were assigned to all bases, only Pochentong was adequately manned and equipped to support any type of field-level repair. As a consequence, Pochentong provided intermediate-level maintenance support for all the other bases. Maintenance activities at the outstations had the capability for minor repair, but, in reality, their supply support was inadequate even for this purpose. Often the outstations requested support from Pochentong even when the base actually had personnel to do the job. The primary reasons for lack of maintenance

[REDACTED] [REDACTED]

[REDACTED] [REDACTED]

capability at the outstations were lack of adequately trained personnel, lack of adequate equipment, and a shortage of directors of maintenance with experience and initiative.

Largely because of the influence of the LMAT personnel, maintenance performed at Pochentong was improving in all areas until the onset of the 1975 offensive. Because of the LMAT contribution, the personality of the Director of Maintenance, and the continuing maintenance training program at Udorn, the non-depot-level KAF maintenance at Pochentong was making satisfactory progress towards becoming self-sufficient.

(2) Supply.

Overall, KAF supply was a satisfactory operation, improving steadily, and capable of supporting the KAF flying mission. All military supplies and major items, except ammunition and POL, were received through the Foreign Assistance Office (FAO) warehouse, where the items were inventoried and distributed and title was transferred to the appropriate service. The warehouse was under the jurisdiction of the FANK, but it was actually supervised by third-country nationals under contract to the MEDIC Army Division. A large part of the warehouse's job was to document shipping discrepancies and shortages, because a great deal of pilferage took place before items arrived in-country. In some cases, entire CONEXes, still banded and locked, were found empty when opened at the warehouse. Items most subject to pilferage were handtools, vehicle parts, communications spare parts, clothing, and other items with commercial appeal.

KAF operated under a manual supply system, similar to US models. Under the Hq KAF G-4 were Chief of Supply, POL, and Personal Equipment. The Chief of Supply had three branches, Management and Procedures, Supply Management, and Materiel Facilities. All branch chiefs were qualified and capable of performing their duties. Two LMAT personnel, one American and one third-country national, were assigned to assist in procedural matters, such as warehousing techniques, stock control, and funds management. They also helped with translation and with drafting messages to and from depots in the States.

The primary supply problems were those which usually arise from the lack of interface between a manual supply system and a computerized one. While a stock record clerk was following up on an overdue shipment, the property could actually have been received and be on hand. Similarly, a priority requisition was frequently dispatched at the same time the item was being received in a routine shipment.

[REDACTED] [REDACTED]

[REDACTED] [REDACTED]

Other problems in supply which were not related to the manual system were the lack of technical data for the AU-24 aircraft, the XM-93 and XM-197 gun systems, and some vehicles and equipment. This lack of technical data contributed to many cancellations of requisitions, many of which were commercial items with long leadtimes. Storage facilities were inadequate, but in April 1975, a re-warehousing project was in progress, as well as construction of a new open storage area. Both projects were progressing well and would have reduced warehouse refusals on property-on-hand which could not be located. KAF supply was also undermanned, and it was never able to establish a much-needed inventory section to reconcile stock record cards with actual warehouse balances.

The KAF stock levels were established for a six-month period with reorder points at the three-month level. The account consisted of 60,000 line items with a dollar value of \$10M.

Materiel consumption was at an all-time high during the 1975 Dry Season Offensive because of the increased flying mission. However, requisitioning came to an abrupt halt in late March because of the reprogramming of other O&M funds to support ammunition, FGL, and aerial delivery equipment. The halt in requisitioning, coupled with the absenteeism of LMAT and KAF personnel due to rocket barrages at Pochentong, led to the deterioration of the supply functions.

c. Training. The FY 1975 KAF training program was originally programmed for \$1.2M, of which all but about \$.3M was scheduled to be conducted in the United States, with the remainder in Thailand. With the June 1974 Joint Chiefs of Staff decision to allow the NACTHAI Training and Logistics Detachment (TLD) at Udorn RTAFB to continue operation in FY 1975, all but about \$.3M of the total was reprogrammed for USAF Udorn training, exactly reversing the original percentages.

The principal role of the Udorn Detachment was to upgrade the skills of both pilots and maintenance specialists by giving them contact with experienced USAF instructors and actual USAF shop practices. Although most of the original training of the KAF had been completed prior to the start of FY 1975, KAF had neither the time nor the expertise in-country for necessary flight standardization and evaluation, nor for technician upgrade training to the 5-, 7-, and 9-levels. The 1975 trend with Udorn flying training was more quality-oriented, away from ungraduate pilot training and towards combat crew training, instrument qualification courses, and advanced forward air control techniques. In the Maintenance specialties, the trend was

[REDACTED] [REDACTED]



[REDACTED] [REDACTED]

away from the entry level training of the 3-level worker and was oriented towards improving the higher skill levels. In addition, there were limited programs to expose aircraft maintenance officers and other KAF middle-level managers to a coordinated USAF maintenance system.

In general, the Udorn training detachment compensated for the fact that the USAF had never built facilities nor conducted air operations from within the Khmer Republic. Because USAF personnel could not train the KAF in-country on account of headspace and other Congressional limitations, the detachment provided a way for USAF skills to be transmitted out-of-country. Virtually all of the regular program scheduled for Udorn was completed before the fall of the Khmer government on 17 April 1975, although a few recently added programs, which had not yet started, had to be cancelled.

The Udorn Detachment also provided a facility and a base of operations for the C-123 Mobile Training Team (MTT) from the United States which came to Udorn early in January 1975 to train ten C-123 crews and one hundred C-123 maintenance specialists. This training was in support of the KAF C-123 program for self-sufficiency in in-country airlift, a mission KAF was to assume on 1 July 1975. By the middle of April 1975, five crews had been completely trained, the other five were well on their way, and over half of the C-123 maintenance specialists had completed training--all well ahead of schedule. Instructors from the Udorn training detachment taught some of the C-123 maintenance courses, thereby saving on MTT TDY costs, and all MTT students received language training of up to two months from Udorn personnel.

A unique aspect of the Udorn training was the funding of the operation. Because of training fund limitations, only travel and living allowances for students, plus fuel, ammunition, certain fixed overhead costs, and the salary of a professional language instructor, were paid from AF MAP training monies. The bulk of the flying hours costs for the flying training were paid directly out of KAF operating fund lines, eliminating the need for fixed course costs. Funding in this way contributed to the flexibility of the training offered and allowed more training to be done for the training dollar spent.

By contrast, the KAF training conducted in the United States during FY 1975 was not significant. A quarter of the program had to be cancelled after the fall of the Khmer government, leaving only about fifty students in training in the States at that time, at a total FY 1975 cost of about \$.2M. For FY 1976, it had been planned to further

[REDACTED] [REDACTED]

[REDACTED] [REDACTED]

curtail KAF training in the States, restricting it almost entirely to professional military education and rotary-wing training not available elsewhere.

During FY 1975, there was an indication that the reservoir of trainable KAF personnel was fast being exhausted. It became more and more difficult to find KAF personnel qualified with the proper language skills for training in the States, and one advantage of the Udorn program was its capacity to take relatively unskilled personnel and to teach them to do a specific job. Much of the maintenance training at Udorn was performed through interpreters, so that verbal aptitude (which may be very different from mechanical aptitude) was not so much a problem.

The wisdom of the JCS decision to continue to train Kmer at Udorn during FY 1975 was subsequently seen in a number of areas:

(1) Udorn training was specifically tailored to the needs of the KAF, using actual KAF aircraft and support equipment, and duplicating as much as possible actual tactics and maintenance used in-country. By contrast, training in the States was increasingly too sophisticated for a KAF still operating in a pre-jet air force environment. During the year, familiarization training was cancelled by Air Training Command on a broad range of maintenance and support skills because the kinds of equipment used by the Kmer were no longer in use in the States.

(2) Lead times were considerably reduced over both training with the Royal Thai Air Force (no new RTAF training was programmed in FY 1975) and training in the States. Flying training programs with the RTAF were preceded by a minimum of six months of English language training, and even then, there were problems because English was not a native language for either student or instructor. Students in the States received at least eight weeks of language training at Lackland, and frequently longer, before starting their formal training. At Udorn, an innovative English-language program, more specialized than the usual Defense Language Institute curriculum but using DLI materials and supervision, allowed most students to enter training directly, after only three weeks of intensive English training. At times, USAF NEOs from the maintenance shops volunteered to teach the special vocabularies of their maintenance areas. English training continued concurrently with the technical or flying training. The results were obvious in the high caliber of student produced and also by more objective standards such as the English Comprehension Level examination, on which Udorn students did as well as, or better than, Lackland-trained students.

(3) The Udorn Detachment exposed the Kmer to the atmosphere of an American base, complete with American television, without completely cutting them off from their Kmer way of life. In the States, there were frequent emotional and psychological problems, especially with unsophisticated NEOs, when a student found himself the only Kmer on a large, impersonal Air Force base. At Udorn, the students were

[REDACTED] [REDACTED]

[REDACTED] [REDACTED]

billeted with their countrymen, they ate most of their meals at a special civilian restaurant on base which cooked food palatable for Khmers, and a Khmer cadre took care of day-to-day problems and counseling. Consequently, morale was very high, and training took place in a receptive atmosphere. At the same time, Khmer students were trained by highly-motivated, USAF instructors with broad experience in such training.

(4) The Udorn training program was flexible enough to respond to changing conditions in-country, and frequent TDY visits to Phnom Penh by the Udorn USAF instructor cadre assured that the curriculum was responsive to these changes. By contrast, training in the States generally required a long lead time, and the students were locked into a fixed curriculum broadly applicable to many countries and conditions, but often of limited relevance to the Khmers. The Udorn program was reviewed periodically throughout the year and was changed as necessary with direct coordination between Hq KAF, the MEDTC AF Training Officer, and the MACRIAI Director of Training and Logistics (DPL). The fact that the DPL was also the Chief, MEDTC Air Force Division, for a six-month TDY period during this fiscal year made this coordination all the easier.

In general, the training provided the KAF out-of-country slowed the KAF in developing its own in-country training base. Although in the short term this was contrary to the broad goals of the US military assistance program, in the case of Khmer Air Force, there were immediate needs and pragmatic exigencies which suggested that training was better performed out-of-country. If peace were to have come during FY 1975 or even in 1976, much of the Udorn program could have been transferred in-country, and even in the 1975 program there was provision for KAF instructor pilots and maintenance instructors. But the immediate task at hand was to fight the war, and it was apparent at Hq KAF that this mission was incompatible with simultaneously developing an in-country training capability--KAF resources were simply too thin to perform both missions concurrently. Hq KAF received the Udorn training very enthusiastically and, except towards the end when the manpower demand became too great, fully supported the program.

d. Operations.

The Khmer Air Force operational capability is discussed functionally in the Command and Control, Airlift, and Strike subsections below. Essentially the KAF was organized with two main operating bases (MOBs), Pochentong and Battambang, and three Forward Operating Locations (FOLs), Krong Cham, Ream, and Kompong Chhnang, although one MOB (Battambang) actually had only FOL capability. The bases are shown on the next page.

[REDACTED] [REDACTED]

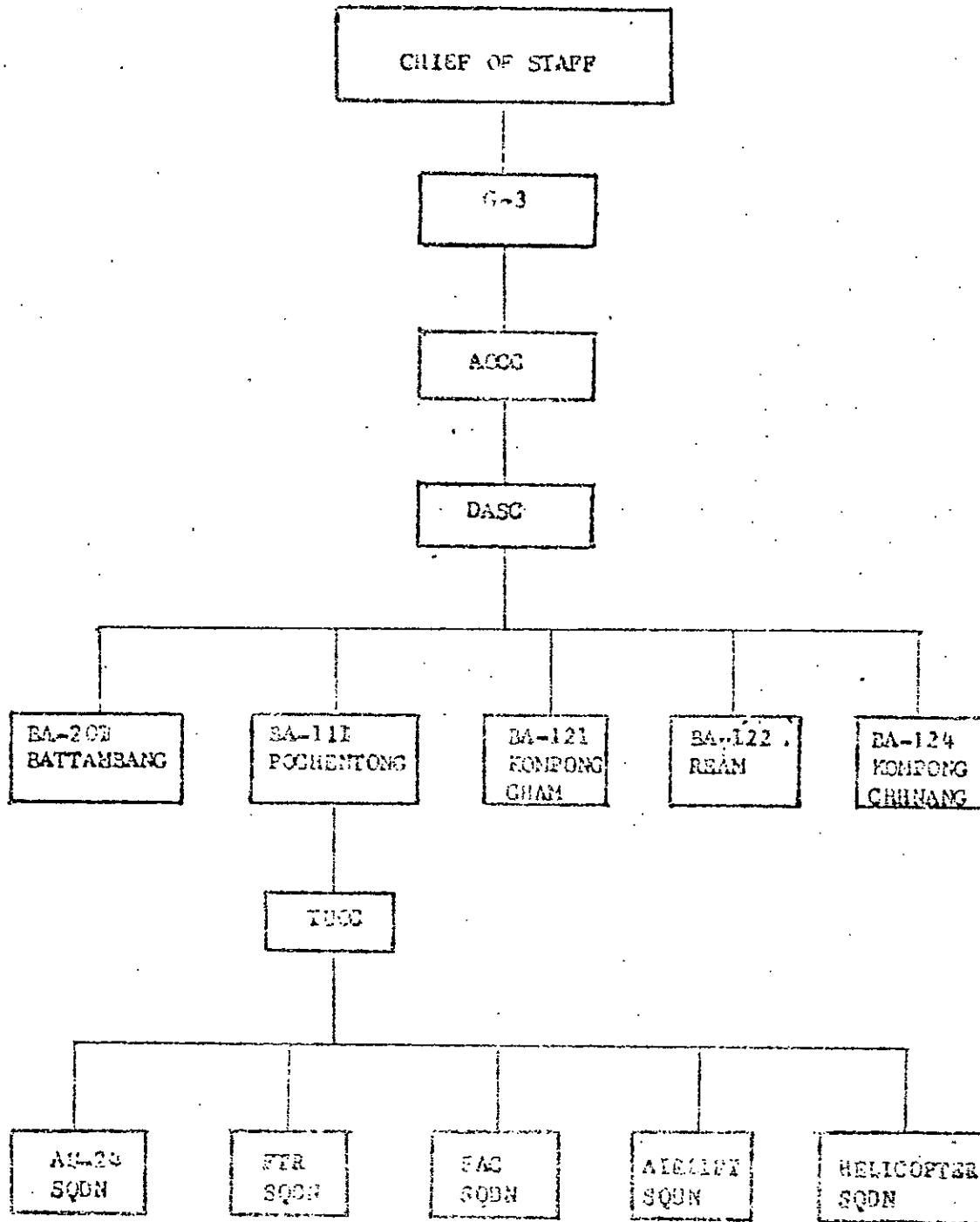

GRAPH 2. AIRBASE ORGANIZATION

[REDACTED] [REDACTED]

(1) Command and Control.

The KAF Tactical Air Control System (TACS) was an unsophisticated version of the classical US Air Ground Operations model. For example, to obtain immediate tac air support, the requesting unit passes the request up the chain of command of the parent unit. As the request is passed, it is evaluated to determine if organic resources can meet the requirement. Once the decision is made to use tac air, the ground commander or Air Liaison Officer (ALO) calls the Direct Air Support Center (DASC) or the overhead Forward Air Controller (FAC), who in turn notifies the DASC. The DASC then calls the Air Operations Center (AOCC), which contacts the Tactical Unit Operations Center (TUOC). The TUOC, in turn, scrambles the required aircraft.

On paper the system appeared to be adequate for Khmer combat operations; however, there were a number of problems which prevented the optimal utilization of Khmer air assets:

(a) Poor communications. The land lines between the DASC, the AOCC, and the TUOC suffered frequent outages which took days to repair, and in many instances, the unreliable municipal telephone system was the only means of communication. Radio contact with units in the field and the forward operating locations was often erratic, and communications security was essentially non-existent.

(b) Inexperienced personnel. During the period of the US bombing in-country, the DASC was run primarily by US personnel. With the termination of the bombing, US personnel were withdrawn, and the Khmer DASC was left short of experience and expertise to effectively direct DASC operations. The DASC Commander, Lt Col Em Samoeun, the only KAF officer with the necessary expertise, was in poor health and worked only during the day. At night, the DASC was left completely in the hands of junior officers who were very hesitant to make decisions that would alter the priorities set down by the day duty officer or to respond decisively to aircraft aborts or tactical emergencies. Hence, the night DASC operations lacked the necessary flexibility and decision-making supervision to run the night air war. As a result of Air Force Division recommendations, KAF decided to assign more high-ranking personnel to the DASC; however, they were still in training and not yet effective by mid-April 1975.

(c) Lack of coordination between FANK, IAK, and KAF. At all three Khmer headquarters, the independent personalities of the top commanders and the lack of adequate understanding of joint operations hindered an effective interface between KAF and the other branches. Past practices of decentralizing the control of air assets continued to influence the thinking of high-level planners. Prior to the Tactical Air Improvement Plan, air assets were parcelled out to the regional commanders, and there was no machinery available to divert or quickly mass the available air from one region to another and thus maximize effectiveness. This problem was corrected by the changeover to the existing Tactical Air Control System; however, sometimes the FANK/IAK planners overlooked the new arrangement. Several times a large ground operation requiring air support was planned without KAF representation, and often cancellations or postponements of planned opera-

[REDACTED] [REDACTED]

[REDACTED] [REDACTED]

tions were not passed on to the KAF. For instance in February 1975, a choke-point clearing operation on the Mekong was postponed for twelve hours. The KAF was not advised of this decision and flew ten preparatory strikes prior to finding out about the postponement. In March 1975, there were at least two instances when KAF flew multiple strike sorties to destroy anti-shipping blockades in support of river convoys that had already been cancelled. One noteworthy exception to the usually poor coordination was the airborne command post flown in support of Mekong convoys until their termination caused by the enemy's introduction of mines in the river. A C-47 piloted by the KAF commander usually carried the MNK commander plus a senior FANK artillery officer. Air and artillery support was coordinated directly and efficiently.

(d) Lack of coordination at lower echelons. Repeatedly, when the ground forces blamed their failures on lack of tac air support, subsequent MEDTC investigations revealed that the tac air request did not get into the proper request channel. There were also instances of tac air's arriving late, arriving early, or not arriving at all. Many such problems could have been solved by having more effective FANK/KAF interface and communications at the working level. Although there was an ALO with a MK-108 jeep at each division and at some lower levels, a mutual lack of full understanding of the TACS, the inherent Khmer reluctance to become involved in another's business, the paucity of strong, aggressive ALOs, the late decisions by some ground commanders to request tac air, and an almost universal lack of understanding of the proper application of tactical air power--all significantly detracted from the total tac air potential. In short, the Khmer Air Force had grown at such a pace that the military structure did not have the expertise to plan and exploit fully the capabilities of tac air.

In an effort to correct some of these coordination problems, fifty FANK and MNK officers were sent to Udorn to attend a twenty-day Air/Ground Operations (AGOS) course, and thirty-nine FANK personnel were trained as Forward Air Guides (FAGs). The AGOS instructional text on Air Operations was translated into Khmer, and in March 1975, three hundred copies were procured for distribution to the FANK units. In February 1975, a program for FANK airborne artillery observers was initiated. Selected FANK artillery observers were teamed up and flew with KAF FACs to provide better communications and coordination. These and other programs to improve coordination between the Khmer services were just beginning to bear some fruit when the U.S. support effort terminated.

## (2) Airlift

Ten C-123s, the backbone of KAF airlift resources, performed both airland and airdrop missions, with supplemental airlift provided by C-47s and UH-1H helicopters. The KAF was to have been self-sufficient in in-country airlift operations by 1 July 1975, and the programmed increase of the airlift assets from 12 to 18 C-123s was considered adequate to handle the normal daily requirements. In pursuit of the

[REDACTED] [REDACTED]

[REDACTED] [REDACTED]

(1) Command and Control.

The KAF Tactical Air Control System (TACS) was an unsophisticated version of the classical US Air Ground Operations model. For example, to obtain immediate tac air support, the requesting unit passes the request up the chain of command of the parent unit. As the request is passed, it is evaluated to determine if organic resources can meet the requirement. Once the decision is made to use tac air, the ground commander or Air Liaison Officer (ALO) calls the Direct Air Support Center (DASC) or the overhead Forward Air Controller (FAC), who in turn notifies the DASC. The DASC then calls the Air Operations Center (AOCC), which contacts the Tactical Unit Operations Center (TUOC). The TUOC, in turn, scrambles the required aircraft.

On paper the system appeared to be adequate for Khmer combat operations; however, there were a number of problems which prevented the optimal utilization of Khmer air assets:

(a) Poor communications. The land lines between the DASC, the AOCC, and the TUOC suffered frequent outages which took days to repair, and in many instances, the unreliable municipal telephone system was the only means of communication. Radio contact with units in the field and the forward operating locations was often erratic, and communications security was essentially non-existent.

(b) Inexperienced personnel. During the period of the US bombing in-country, the DASC was run primarily by US personnel. With the termination of the bombing, US personnel were withdrawn, and the Khmer DASC was left short of experience and expertise to effectively direct DASC operations. The DASC Commander, Lt Col Em Samoeun, the only KAF officer with the necessary expertise, was in poor health and worked only during the day. At night, the DASC was left completely in the hands of junior officers who were very hesitant to make decisions that would alter the priorities set down by the day duty officer or to respond decisively to aircraft aborts or tactical emergencies. Hence, the night DASC operations lacked the necessary flexibility and decision-making supervision to run the night air war. As a result of Air Force Division recommendations, KAF decided to assign more high-ranking personnel to the DASC; however, they were still in training and not yet effective by mid-April 1975.

(c) Lack of coordination between FANK, MNK, and KAF. At all three Khmer headquarters, the independent personalities of the top commanders and the lack of adequate understanding of joint operations hindered an effective interface between KAF and the other branches. Past practices of decentralizing the control of air assets continued to influence the thinking of high-level planners. Prior to the Tactical Air Improvement Plan, air assets were parcelled out to the regional commanders, and there was no machinery available to divert or quickly mass the available air from one region to another and thus maximize effectiveness. This problem was corrected by the changeover to the existing Tactical Air Control System; however, sometimes the FANK/MNK planners overlooked the new arrangement. Several times a large ground operation requiring air support was planned without KAF representation, and often cancellations or postponements of planned opera-

[REDACTED] [REDACTED]

tions were not passed on to the KAF. For instance in February 1975, a choke-point clearing operation on the Mekong was postponed for twelve hours. The KAF was not advised of this decision and flew ten preparatory strikes prior to finding out about the postponement. In March 1975, there were at least two instances when KAF flew multiple strike sorties to destroy anti-shipping blockades in support of river convoys that had already been cancelled. One noteworthy exception to the usually poor coordination was the airborne command post flown in support of Mekong convoys until their termination caused by the enemy's introduction of mines in the river. A C-47 piloted by the KAF commander usually carried the MNK commander plus a senior FANK artillery officer. Air and artillery support was coordinated directly and efficiently.

(d) Lack of coordination at lower echelons. Repeatedly, when the ground forces blamed their failures on lack of tac air support, subsequent MEDTC investigations revealed that the tac air request did not get into the proper request channel. There were also instances of tac air's arriving late, arriving early, or not arriving at all. Many such problems could have been solved by having more effective FANK/KAF interface and communications at the working level. Although there was an ALO with a MK-108 jeep at each division and at some lower levels, a mutual lack of full understanding of the TACS, the inherent Khmer reluctance to become involved in another's business, the paucity of strong, aggressive ALOs, the late decisions by some ground commanders to request tac air, and an almost universal lack of understanding of the proper application of tactical air power--all significantly detracted from the total tac air potential. In short, the Khmer Air Force had grown at such a pace that the military structure did not have the expertise to plan and exploit fully the capabilities of tac air.

In an effort to correct some of these coordination problems, fifty FANK and MNK officers were sent to Udorn to attend a twenty-day Air/Ground Operations (AGOS) course, and thirty-nine FANK personnel were trained as Forward Air Guides (FAGs). The AGOS instructional text on Air Operations was translated into Khmer, and in March 1975, three hundred copies were procured for distribution to the FANK units. In February 1975, a program for FANK airborne artillery observers was initiated. Selected FANK artillery observers were teamed up and flew with KAF FAGs to provide better communications and coordination. These and other programs to improve coordination between the Khmer services were just beginning to bear some fruit when the U.S. support effort terminated.

## (2) Airlift

Ten C-123s, the backbone of KAF airlift resources, performed both airland and airdrop missions, with supplemental airlift provided by C-47s and UH-1H helicopters. The aim was to have been self-sufficient in in-country airlift operations by 1 July 1973, and the programmed increase of the airlift assets from 12 to 18 C-123s was considered adequate to handle the normal daily requirements. In pursuit of the

[REDACTED] [REDACTED]



[REDACTED] [REDACTED]

self-sufficiency goal, a USAF Mobile Training Team was established at Udorn in January 1975 to train ten more C-123 crews and one hundred additional C-123 mechanics. These additional aircrews and maintenance personnel were to provide the needed manpower to support the six additional C-123s delivered in early 1975.

The self-sufficiency program suffered an initial setback with the loss of two C-123s in aircraft accidents in the fall of 1974. This reduced the number of KAF C-123s to ten, two of which were usually in Bangkok undergoing major repairs. The average number of C-123s available daily was three to five. This number was inadequate to support all the KAF commitments, and MAC was continually concerned about the shortage of available airlift sorties. Other problem areas were lack of adequate aerial port facilities at Pochontong and a shortage of qualified riggers. The rigger problem was solved by training thirty-nine Army riggers in Thailand, but the lack of airframes and adequate aerial port facilities continued to be a problem until the end.

Despite these problems, KAF was able to provide support for the FANK enclaves until March 75, when contract C-123s took over a major portion of outstation resupply. KAF air delivery techniques were simple yet effective. Air drops using visual references were flown at 4500 to 5000 feet. This technique provided a cargo recovery rate of about 98% and reduced the exposure to ground fire. No KAF aircraft flying airdrop missions were lost to enemy ground fire. By the end of August 1974, the KAF provided total ammunition supply to Takeo, Kampong Thom, Svey Rieng, and Das Kanchor.

With the increase in C-123 capabilities, the importance of the C-47 continued to diminish. In January 1974, C-47s flew 256 missions; by January 1975, the total was down to 33. In January 1975, six C-47s were theoretically available; however, of the two in-country, only one was available on an average day. By October 1974, the missions flown by C-47s dropped below fifty a month, and the C-47 had ceased to be a significant factor in KAF airlift.

The OH-1H played an important role in the short haul, small landing zone, resupply effort. However, by the second quarter of 1974, the OH-1H fleet's operational readiness rate had declined to an unacceptable average of 49%. Lack of adequate maintenance and a weak preventive maintenance program caused the helicopter fleet to deteriorate rapidly. "Operation Rotor Head Express," a one-time repair of the KAF helicopter fleet by a US Army Team, was undertaken in June 1974 at Utapao AB, Thailand. As a result of training maintenance personnel, an internal reorganization, and a number of personnel changes, KAF was able to bring the OH-1H in-commission rates up to acceptable standards.

Aside from operational problems, the KAF effort to train suffered greatly because of the high incidence of aircraft accidents and ground. On return from tactical missions, aircraft often were used to haul contraband and paying passengers. The KAF also had fish ponds and a few of the favorite cash-producing methods. Attempts to install

[REDACTED] [REDACTED]

[REDACTED] [REDACTED]

these practices were never-ending. Abuses would decrease after strong warnings from MEDJTC, only to reoccur a few weeks later.

All in all, the KAF airlift self-sufficiency program was progressing satisfactorily until the beginning of the 1975 Dry Season Offensive. Eventually the increased rocket attacks against Pochentong and the deteriorating military situation forced KAF airlift to reevaluate the priorities. In-country training and other long range plans for self-sufficiency were shelved in favor of day-to-day tactical operations. In spite of a steadily mounting toll of aircraft to enemy rockets, KAF airlift continued to function until the fall of the Republic. Even after the fall, KAF airlift was able to evacuate numerous KAF personnel and their dependents to Thailand.

### (3) Strike.

Khmer air strike operations were conducted by T-28Ds, AU-24s, AC-47s, and UH-1H Gunships. The antiquity and limited fire power of these weapon systems were constraints with which the KAF learned to live. The tactical situation and lack of enemy heavy AA defenses during February 1974 to April 1975 allowed for essentially unrestricted employment of all the Khmer strike aircraft. If the enemy had introduced the SA-7, heavy caliber weapons (i.e. 23 mm or above), or radar-controlled AA, KAF would not have been able to operate effectively in areas defended by such weapons.

The majority of KAF air strike operations were conducted out of Pochentong Air Base. A limited strike aircraft capability was available from Battambang, Kampong Cham, Ream, and Kampong Chhnang; however, due to limited maintenance and support facilities, these bases were essentially forward operating locations.

One of KAF's significant weaknesses was in the area of night and all-weather operations. The T-28 did not fly at night and it had a KAF-imposed 3,000-foot minimum altitude for delivery. These restrictions greatly reduced KAF's effectiveness. The brunt of night air support was provided by the AC-47s. The AU-24s and UH-1H gunships were also available for night operations, but limited ordnance loads and loiter time restricted these aircraft to close-in targets.

Combat tactics was another area needing further improvement. The majority of the T-28 pilots were not familiar with advanced combat tactics. For the most part, they flew the classical, scoreable-range box pattern, using high-angle delivery techniques. Mutual fire support and random roll-ins were seldom practiced. The preference for high-angle deliveries of all munitions affected accuracy and reduced the destructive effects of napalm and other lay-down ordnance.

[REDACTED] [REDACTED]

[REDACTED] [REDACTED]

To correct these problems, training courses were organized at Udon to provide instruction to the newer T-28 pilots in advanced tactics and instrument flying. A course in night operations was programmed to start in FY 1976.

Notwithstanding these problems, the KAF continued to grow in strength, capability and effectiveness. The enhanced capability of KAF in tactical operations was one of the most significant improvements in the newer military posture. During 1974, the Tactical Air Improvement Plan-Cambodia (TAIP-C) began in January 1974 as a concerted effort to bolster areas of logistics, training, maintenance, support equipment, resource management, and command and control. The most visible success of the program was the training of the RVNs and fighter pilots at Udon to transform what had previously been called a flying club into an aggressive, tactically effective, and professional team operation. T-28 strike sorties jumped from a monthly average of 1,487 for the first four months of 1974 to 2,711 sorties in July. The effectiveness of the strike force also grew as fighters worked with FAC's trained in visual reconnaissance techniques. By January 1975, 60% of all T-28 strike sorties were under direct FAC control.

It was recognized from the onset of TAIP-C, however, that to exploit the improved KAF capabilities would require better planning, coordination, and cooperation between all military services. In addition, just at the time when KAF was starting to flex its new muscles, funding limitations dictated an ammunition conservation program. As a consequence, the monthly T-28 sortie average fell to 1,362 for the last three months of 1974 in order to comply with air munitions expenditure guidelines of \$82,000 per day. When the 1975 offensive posed an immediate threat to Phnom Penh, the T-28B sortie rate increased to an average of 1,832 for January, February, and March 1975. Ammunition conservation restrictions were waived in the face of lucrative enemy targets and narrow tactical emergencies.

New ordnance was introduced to counter the firm entrenchment of the enemy in rocket-launch areas and Lower Mekong River choke points. The CBU-55 was especially effective against the entrenched positions in these areas. Initially produced in response to enemy firing from the Lower Mekong, this unitary cluster bomb was the rocket belt for the first time on 31 January 1975 when 107 enemy positions were destroyed or damaged (five aircraft and equipment destroyed). KAF maintenance efforts. Battle-damage-assessment (BDA) was developed and available and, for most CBU-55 strikes, BDA was reported. However, in a rare instance when the newer Army did not use the area of a strike, over 500 killed-by-air were reported from an CBU-55 expended on 10 April.

Ordnance which brought down planes, such as the CBU, by the F4U 725 Euro, also proved effective. The CBU-55 was used occasionally during the 1975 offensive. The CBU-55 was first introduced on the 24-11 air strike. The CBU-55 was used to bring down a plane to earth on 10 April.

[REDACTED] [REDACTED]

[REDACTED] [REDACTED]

attempt to find a way to deliver hard bombs at night, the "B-123" concept was enthusiastically pursued by KAF. During March 1975, thirty-four C-123 bombing sorties were flown, primarily at night, carrying MK-82's or 25-pound fragmentation bombs.

The MK-82s were loaded one, two, or three to a pallet, with arming wires attached to the pallet. Upon exit from the aircraft, the bombs separated from the pallet, pulling the arming wire and arming the MK-82s. The 25-pound fragmentation bombs were stacked flat, nineteen to a pallet. Upon exit, they were thrown clear and dispersed by the tumbling pallet. Twenty-two MK-81/MK-82s or 190 fragmentation bombs would usually be carried on each "B-123" mission.

e. Final Days of KAF.

Beginning on 15 March 1975, the intensity and accuracy of 107 mm rocket and 105 mm howitzer fire at Pochentong Air Base increased significantly. By 3 April, two aircraft had been destroyed and 39 damaged in these attacks. Aircraft parking, bomb storage, and maintenance working areas had been moved to avoid high-threat areas. By early April, such shifting was a futile exercise, due to the greater coverage of incoming artillery. Aircrew morale remained remarkably high through this period, although most pilots were discouraged by the FANK operational failure and lack of troop aggressiveness in the Rocket Belt.

Maintenance capability was seriously eroded at this time. In addition to daily casualties, absenteeism became a serious problem. The Logistics and Maintenance Assistance Team, which had third-country nationals in every maintenance shop, curtailed operations at Pochentong on 15 March. Besides inflicting physical damage, incoming rockets significantly disrupted all maintenance activity by forcing personnel to flee to cover each time the warning siren sounded.

By 1 April, the continual rocketing and shelling of Pochentong and lack of any progress in counterattacks on the ground made it obvious to MEDTC that KAF's days were numbered. Notwithstanding all these adversities, under the leadership of PGen Ea Chhong, the KAF continued as the last effective fighting force in the Khmer Republic. It was only after the fall of Pochentong, following three days of desperate defense by KAF without assistance from FANK, and after destruction or exhaustion of fuel supplies and munitions, that the decision was made to evacuate aircraft and personnel to Thailand.

As of 18 April 1975, 22 KAF aircraft and 450 KAF personnel and their dependents had reached Thailand and an additional 287 KAF personnel were already out-of-country for various training programs (53 in COMUS and 234 in Thailand).

[REDACTED] [REDACTED]

TABLE 4. KAF AIRCRAFT DISPOSITION

AIRCRAFT IN THAILAND

<u>TYPE</u>	<u>PRIOR 16 APR</u>	<u>EVACUATED 17/18 APR</u>	<u>TOTAL 18 APR</u>	<u>REMAINING IN CAMBODIA</u>
T28B	15	0	15	0
T28D	23	7	35	22
AC47	4	3	7	6
C47	1	0	1	1
AU24	2	1	3	9
UH1H/G	5	8	13	24
T41	0	1	1	12
C123K	8	2	10	7
01G	7	0	7	1
01D	5	0	5	13
01F	0	0	0	1
01A	0	0	0	3
U1A	0	0	0	1
	<u>75</u>	<u>22</u>	<u>97</u>	<u>100</u>

4. CONCLUSIONS.

For the sustained maximum effort of the 1975 Dry Season Offensive, the Air Force Division was satisfactorily organized for its assigned mission, but was inadequately manned. Headspace limitations did not allow enough action officers to accomplish satisfactorily the required end-item utilization inspections necessary to prevent degradation of KAF maintenance and safety practices during this period. Without the assistance of an outside agency (NACTHAI/BTL) to interface with contract maintenance and KAF training activities in Thailand, several additional spaces would have been required to accomplish even the Division's limited mission.

Overall, the reduced FY 1975 MAP for the KAF was unsatisfactory, since investment, construction, facilities, and some O and M lines had been reprogrammed for aerial delivery equipment and ammunition. Even so, after stripping all funds except those essential to continue short-term operations, enough remained in repair, spare parts, weapon spares, and other program lines for KAF to have continued operations through June 1975, if funding for ammunition had been available.

Generally, the KAF's tac air operations in support of ground forces were satisfactory. The strike pilots performed well, were good bombers, and were reasonably aggressive; and they had very capable commanders in Brig Gen Ea Chhong and Col Sak Sombun. Minimal understanding by senior BAKK officers of how best to employ the capabilities of the air arm caused KAF strike operations occasionally to be over-extended, employed piecemeal, or beset with uncoordinated re-

[REDACTED] [REDACTED]

quirements which could have been significantly improved with a viable joint-staff apparatus. Through the personal efforts of General Ba Chhng, however, this situation was improving. Air was too often treated simply as an extension of organic fire and often concentrated on only one area at a time at the expense of other potential missions. KAF was seldom used to its fullest potential, primarily because of the following problem areas:

1. A very thin layer of energetic, effective, and professional middle management.
  2. Inadequate coordination and teamwork, both internally and between services.
  3. Minimal understanding by military leaders of how best to employ tac air.
  4. Inadequate incentives and compensation, which led to poor motivation and improper diversion of resources, time, and energy for personal profit.
  5. Over-centralization of resources at Pochentong Air Base because of limited facilities and communications at the other bases.
  6. Too much dependence on contract maintenance.
  7. A cumbersome and non-responsive supply and logistics network.
  8. One-of-a-kind systems, such as AU-24 aircraft and the XM-197 gun system, difficult to support because technical data and parts were not available in the normal Air Force system.
  9. Lack of standardization, and obsolescence in vehicles and aerospace ground equipment.
  10. Marginal physical facilities (buildings, shops, ramps, revetments)
  11. Lack of an adequate training base in-country, especially for standardization and evaluation of aircraft and for upgrade training of maintenance specialists.
  12. Minimal strike capability during night or marginal weather.
  13. Congressional limitations on funds, mission, and headspace.
  14. Hybrid French/US accounting systems for KAF personnel and materiel.
- [REDACTED] [REDACTED]

[REDACTED] [REDACTED]

Despite these problems, the KAF achieved and sustained satisfactory sortie and operationally ready rates. Aircrews continued to be aggressive, and, up until the end, they inflicted significant damage on the insurgent forces, although they never realized their full potential against interdiction targets. In general, KAF met most goals and fulfilled most expectations of the original MAP and TAIP-C planning.

ANNEX E

AMMUNITION AND SERVICES

1. GENERAL.

The mission of the Ammunition and Services Division was to provide ammunition and logistical services support to the military forces of the Khmer Republic. This mission was accomplished by careful management of assets provided within the constraints of Military Assistance Program funding.

Ammunition Branch had nine personnel to manage the entire ammunition Program in support of an active war. This included funding, monitoring country-wide stockage levels, calling forward tri-service munitions, conducting End-Item Utilization Inspections, inspecting ammunition storage facilities, and supervising a vigorous ammunition conservation program.

The Services Branch had four personnel to manage programs for POL, aerial delivery, and cargo movement. This austere manning level allowed no depth or back-up. The mission could not have been successfully accomplished without the use of Third Country Nationals in the areas of ammunition storage, accounting, and maintenance, as well as in POL operations.

Valuable support was received from United States Support Activities Group (USSAG) in assigning aircraft for airland and airdrop operations and in computer support for ammunition management programs. The Ammunition Activity, MACTHAI Support Group, was very responsive to ammunition call forwards, as were the riggers and the personnel of the 6th Aerial Port for airdrop operations.

2. AMMUNITION MANAGEMENT - PROGRAMMING AND SUPPLY.

Increasing combat activity, escalating costs and completion of major equipment deliveries caused ammunition to completely dominate the Military Assistance Program in terms of funding, as over 80% of every MAP-CB dollar was allocated for this commodity. It was also a major effort in terms of manhours expended assuring timely, responsive positioning of essential stocks. The problems of incremental funding, escalating costs, and the Congressional funding pattern (CRA; NOA; Section 506 drawdown authority) were magnified in the ammunition program due to fluctuating demand and short lead times. Deliveries were accomplished by barge up the Mekong LOC, barge or deep draft ship to Kompong Som, road convoy to Battambang and Sisophon on Thai contract trucks, airland to Phnom Penh by US contract C-130 aircraft, and airdrop to isolated enclaves by contract C-130 aircraft. The FY 74 ammunition program was funded at \$310.4 million and the FY 75 program at \$160.3 million. Ammunition deliveries to the Khmer Republic from January 1974 until 17 April 1975 totalled 208,562 short tons of Army, Air Force, and Navy stocks, valued at \$445.9 million.



### 3. END ITEM UTILIZATION INSPECTION AND AMMUNITION CONSERVATION.

A lack of training in ammunition logistical management within the Khmer services resulted in chronic over-issues and a measurable munitions loss through improper storage and handling. To combat these losses and attendant unwarranted expenditures, the MEDTC Ammunition EIUI program was reoriented in May from combat units to ammunition activities. 215 Ammunition Inspection visits were made to 31 locations between May 74 and April 75. Resultant recommendations, on-the-spot training of FANK personnel by Third Country National specialists and information gathered by the inspection teams played an important role in improving storage, accountability, handling and in-country logistics. Ammunition waste and hazardous storage situations within the FANK were also significantly diminished.

Between May and December 1974, changes in ammunition logistic procedures within FANK were effective, but staff organization and functioning were suboptimal due to the fragmentation of responsibilities between J-3 and J-4. Inspection visits during this time-frame corrected some logistics problems but could not eliminate over-issues, driven as they were by requests from independent field commanders and improper FANK staffing and prioritizing of requirements. On 1 January 1975, a major staff change was made within FANK to create an Ammunition Logistics Directorate answerable directly to the Commander-in-Chief. Concurrently, a graduated allocation system based on local enemy threat was implemented to reduce issues and realign expenditures. Inspection visits during January, February, and March verified that this positive approach was reducing the amount of ammunition issued without reducing combat capability.

### 4. POL.

With the exception of ammunition, no other expendable commodity required a greater amount of MAP-CB purchase dollars than POL. Costs soared monthly, as reflected in the 450 percent increase in the projected FY 76 MAP-CB POL budget over its FY 73 counterpart.

The FANK POL support system was rudimentary. Antiquated shipping was utilized to transport fuel to Cambodia; storage facilities were often crude and, with the exception of certain key individuals, personnel lacked general POL know-how.

MEDTC faced a continuing challenge in attempting to control the illegal diversion of fuels. Although fuel losses were not totally eliminated, they were drastically curtailed. In view of the high domestic demand for the scarce commodity, this reduction was a particularly significant accomplishment.

Despite these initial shortcomings, the combined efforts and positive attitude of MEDTC, FANK and Khmer civilian POL personnel produced noteworthy results: permanent storage space was significantly increased; an effective POL training program was initiated; accounting procedures were

vastly improved; an into-plane refueling service was instituted; a responsive, effective requisitioning system was maintained; and depots were visited regularly. During the 1975 KC Dry Season Offensive alone, over 2,000,000 gallons of fuel were airlifted to Phnom Penh.

5. TRANSPORTATION.

a. The movement of personnel and cargo into and within the Khmer Republic became increasingly difficult during the period February 1974 - April 1975. While lines of communication became more restricted due to the tactical successes of the KC, PANK demands for logistical support, particularly ammunition, became almost overwhelming. After January 1974, the highway net was essentially closed, except for the segment from the Thai border to Battambang. After 30 January 1975, the KC interdicted all Lower Mekong River cargo traffic. With the loss of the Mekong River LOC, all cargo for the capital region had to be airlifted to Pochentong Airfield. The sustained airlift, primarily conducted by civilian contracted C-130's and DC-8's, moved an impressive total of 123,631 short tons during the period.

b. The largest and longest U.S.-supported aerial delivery resupply mission ended on 17 April 1975 with the GKR capitulation. Between 19 June 1972 and 17 April 1975, the USAF and contract C-130 support had dropped more than 45,000 short tons of ammunition and rice into beleaguered Cambodian enclaves. This extraordinary airdrop effort required the Air Force to fly 3103 airdrop sorties and the Army riggers in Thailand to prepare 52,758 containerized delivery system (CDS) bundles. It was accomplished through the joint efforts and cooperation of US Army riggers and Air Force personnel in Thailand, working closely with MEDTC personnel in-country.

APPENDIX 1 TO ANNEX E

AMMUNITION MANAGEMENT - PROGRAMMING AND SUPPLY

1. GENERAL. The key logistical element of US support to the GKR was the provision of ammunition to its armed forces. No other tangible commodity so dominated the Military Assistance Program in terms of funding requirement or the man-hours expended in assuring that sufficient stocks of the right kind of ammunition were in the right place at the right time. Having restructured their Armed Forces according to US doctrine, the GKR necessarily developed firepower as a cornerstone of its tactics. The provision of sufficient ammunition in support of the firepower was the most vital logistical task that confronted MEDTC.

Generally, the two factors that influence ammunition requirements are the size of the force being supported (specifically, to include quantity and types of organic and supporting weapons) and the intensity of combat. From FY 72 to FY 74, weapons densities/force structure in the GKR rose dramatically; however, from the last half of FY 74 until April 1975, densities generally remained constant or showed a slight downward trend, as combat losses, without offsetting replacement, took their toll (See Tab A). Also affecting ammunition requirements was the shift from massive USAF air support in August 1973 to FANK reliance on its own artillery as the chief means of achieving a firepower advantage. The growing requirement for munitions relative to the remainder of the program, coupled with the ever-increasing cost of munitions, tilted the restricted MAP-CB budget so that ammunition funding accounted for over 80 percent of the total program.

2. THE AMMUNITION MANAGEMENT PROGRAM.

The management of the MAP-CB ammunition program was truly unique in terms of its scope of activity and the high level of interest shown in it. The scope ranged from direct coordination with OSD and the Military Departments for funding and billing, to the inventory of individual rounds of ammunition at various isolated enclaves. The high level of interest was characterized by phone calls at any hour from staff personnel of CINCPAC, JCS, or OSD, who requested data updates to aid their monitoring of stock or funds status. Added to the normal supply procedures of receipt, storage, issue, inspection and maintenance of stocks was the additional responsibility of maintaining detailed financial records to insure that the MAP-CB ammunition budget was not exceeded. Thus "dollars" became the hub of the ammunition program around which all other functions revolved.

a. Funding.

In order to support the active conflict, over 80 percent of total MAP-CB funds were allocated for the purchase of ammunition. In

accordance with the high priority placed on this commodity and the large volume required to sustain the active combat situation, all munitions were funded as a separate program.

(1) Ammunition requirements for FY 74 were projected at \$350.7M, with \$310.4M of that amount actually funded under NOA and 506 drawdown authority. Requirements for FY 75 were estimated at \$381.5M, with only \$160.3M being funded.

(a) FY 74 funds available for ammunition:

New obligation authority funds:	\$ 92.3M
Section 506 drawdown funds:	<u>\$218.1M</u>
TOTAL	<u>\$310.4M</u>

(b) FY 75 funds available for ammunition:

New obligation authority funds:	\$109.7M
Section 506 drawdown funds:	<u>\$ 50.6M</u>
TOTAL	<u>\$160.3M</u>

(2) An increasing dependency on KAF air support caused air munitions to rise from 5.8 percent to 15.1 percent of the total ammunition program between FY 74 and FY 75.

FUNDS ALLOCATION BY SERVICE

FY 74		FY 75	
GROUND MUNITIONS	\$291.0M	GROUND MUNITIONS	\$135.7M
AIR MUNITIONS	\$ 18.0M	AIR MUNITIONS	\$ 24.2M
NAVAL MUNITIONS	<u>\$ 1.4M</u>	NAVAL MUNITIONS	<u>\$ 0.4M</u>
TOTAL	<u>\$310.4M</u>	TOTAL	<u>\$160.3M</u>

(3) The problems of escalating costs and incremental funding, which plagued all MAP-CB programming efforts, were magnified in the ammunition program due to the fluctuating demand and short lead-times.

Incremental funding every 30 days required a request and justification which restricted planning to, at best, two months into the future. The Congressional funding pattern (CRA, NOA funding, and 506 drawdown authority) further restricted planning efforts due to the delays experienced in obtaining the funds. Of 13 funding requests in FY 75, six were special funding requests required to meet the urgent needs of the moment, while deliberations were going on as to the next step in funding. Of the 13, seven were overlapping, thereby causing an accordion effect in the pipeline, as short as it was.

Increases in the cost of munitions continually reduced the purchasing power of the ammunition program. A two-percent-per-month increase was the planning guideline; however, in some cases the average increase exceeded the guidelines.

PRICE INCREASES OF SELECTED MUNITIONS

<u>ITEM</u>	<u>JULY 73</u>	<u>JAN 74</u>	<u>NOV 74</u>	<u>MAR 75</u>	<u>% INC</u>
5.56MM BALL	.06	.082	.08	.10	66
.30 CAL LKD	.09	.12	.18	.13	44
40MM GRENADE	2.00	3.50	3.60	3.60	80
60MM MORTAR HE	9.00	10.00	13.58	13.79	53
81MM MORTAR HE	18.00	23.50	27.00	31.26	73
105MM HE (HOW)	26.00	28.50	35.70	41.49	59
500 LB GP BOMB	125.00	125.00	313.91	314.29	151

These escalating price increases combined with uncertain out-year funding so that approved ammunition funding consistently fell short of requirements.

(4) The method of programming ammunition requirements was initially based on the accepted method of individual record control numbers (RCN's) for each type of munition. Considering the six-digit limitation of the in-use computer program and the requirement to provide separate RCN's for each type of funding, the ammunition program in FY 74 had 143 separate RCN's. In FY 75, with the acceptance of the GOO line concept (generic code "GOO" dollar lines), the number of RCN's was reduced to six. This change greatly increased the flexibility of the program.

b. Delivery of ammunition to the GKR. The MAP-CB funded ammunition pipeline to Cambodia was relatively short in comparison to other types of supply. A call forward message (request for ammunition) was generated by the Ammo Branch MEDTC and transmitted to the ammunition activity (MACTSPT GP), Vayama, Thailand as the action agency. This was true for both SCOOT and SCOOT/T operations (discussed in Transportation annex). Therefore, MAP-CB incurred no obligation to fund stocks in the pipeline from CONUS to Thailand, as such stocks belonged to the military departments (Army, Air Force, Navy) until called forward.

There were four methods used to resupply the GKR from U.S. stocks: (1) airlift of munitions by U.S. contract C-130 or DC-8 aircraft from U-Tapao, RTNAB to Pochentong Airfield; (2) airdrop of munitions by U.S. contract C-130 aircraft to various isolated enclaves; (3) water delivery by barge convoy up the Mekong LOC to Phnom Penh or barge/deep draft ship to Kompong Som; and (4) road convoy by Thai contract trucks to Battambang and Sisophon. Title transfer from MAP-CB to the GKR there-

fore took place in Phnom Penh (airland, airdrop and barge convoy), Kompong Som (barge/deep draft) and Battambang/Sisophon (road convoy). From January 1974 until 17 April 1975, 208,562 short tons of munitions valued at \$445.9 million were delivered to the GKR (see Tab B).

3. THE CALL FORWARD SYSTEM. Based on a Third Country National (TCN) reporting system, stocks in the Phnom Penh depot complex, Battambang, Siem Reap, and Kompong Som depots were closely monitored by the Ammo Management Section, MEDTC. In order to maintain stocks at the 30-day CINCPAC approved Required Supply Rate (RSR), a call forward message was transmitted to the Ammo Activity, Vayama, Thailand with an appropriate Required Delivery Date (RDD), specifying type of munition, quantity, and method of delivery (surface, airdrop, or airland) depending on the urgency of need and the in-country location to be resupplied. Acting on this message, the Vayama Ammo Activity filled the request using the appropriate mode of transportation.

4. RECONCILIATION OF RECEIPTS. Documentation to maintain an audit trail of stocks from call forward to title transfer (to the GKR) was as follows:

- a. MEDTC Call Forward Message
- b. Vehicle/barge/ship manifest (except airdrop)
- c. DA Form 1348's (shipping document)
- d. MEDTC TCN receipt document (for all modes except airdrop)
- e. MACT SPT GP issue message (document of record for billing purposes)
- f. MEDTC Report of Shipment (REPSHIP)

Using this documentation, and working closely with Vayama Ammo Activity, MEDTC documentation personnel were able to accurately resolve discrepancies between what was called forward and what was received.

5. RECORD OF ISSUES. Once ammunition was received in country and title transferred to the GKR, MEDTC had no operational control over stocks; however, from a supply point of view, the stockage position at the four in-country receipt locations (Phnom Penh depot complex, Siem Reap, Battambang, and Kompong Som depots) was closely monitored as mentioned previously. TCN's were the executors for this responsibility. A hand-carried daily transaction status (receipts, issues, on-hand balance) was required from the TCN's located at Phnom Penh depot complex. This information was also received daily by radio from TCN's located at Battambang, Siem Reap, and Kompong Som, making it possible to accurately determine the level of issues from the major depots. As ammunition conservation became more critical, the ability to rapidly and accurately obtain information on stocks status became an invaluable management tool. During the period January 1974 until 17 April 1975, ammunition issues from the four in-country receipt locations totalled 216,257 short tons valued at \$462.4 million. (See Tab C for a breakout by month).

TAB A TO APPENDIX I TO ANNEX E

REPRESENTATIVE WEAPONS DENSITIES

	<u>JAN 73</u>	<u>JAN 74</u>	<u>MAR 75</u>
M79 Grenade Launcher	12,638	22,373	18,522
81MM Mortar	250	1,192	724
4.2" Mortar	7	37	36
105MM Howitzer	110	227	260
106MM Recoilless Rifle	41	121	130
155MM Howitzer	0	24	22

COMBAT INTENSITY FACTOR\*

Jan 74	2.8	Jun	5.5
Feb	3.7	Jul	4.8
Mar	3.1	Aug	3.2
Apr	2.9	Sep	4.2
May	3.5	Oct	5.2

\* The Combat Intensity Factor (CIF) was developed by Headquarters, USSAG in 1974. It was derived using the following formulation:

(ABF-Attack By Fire)

$$CIF = \frac{\text{Total Casualties}}{\text{Friendly Strength}} \left( \text{Total Contacts} + \frac{\text{Enemy ABF's}}{3} \right)$$

NOTE: Calculations using this formula were discontinued in Oct 74; however, the combat intensity continued to escalate, especially during the period January - April 1975.

TAB B TO APPENDIX I TO ANNEX E

AMMO DELIVERIES TO CAMBODIA (SHORT TONS)

FY74 - FY75

<u>MONTH</u>	<u>AIRLAND</u>	<u>AIRDROP</u>	<u>WATER</u>	<u>HIGHWAY</u>	<u>TOTAL</u>
JAN 74	5,020	628	7,648	00	13,296
FEB	2,392	694	33,039	302	23,427
MAR	196	992	15,840	504	17,532
APR	79	3,608	19,495	652	23,834
MAY	0	2,086	5,962	695	8,643
JUN	0	2,236	6,612	735	9,583
JUL	3	1,122	13,515	1,080	15,720
AUG	0	679	8,970	1,003	10,652
SEP	4	592	10,810	2,192	13,598
OCT	0	527	7,429	968	8,924
NOV	0	605	12,483	320	13,408
DEC	5	571	10,991	667	12,234
JAN 75	2,147	381	6,493	1,275	10,296
FEB	11,310	382	0	584	12,276
MAR	7,627	2,426	0	1,036	11,149
1-17 APR	2,837	950	0	203	3,990
<b>TOTAL</b>	<b>31,620</b>	<b>18,479</b>	<b>146,187</b>	<b>12,276</b>	<b>208,562</b>

TOTAL \$ VALUE: \$445.9M



TAB C TO APPENDIX I TO ANNEX E

AMMUNITION ISSUES BY MONTH\*

<u>MONTH</u>	<u>QTY (SHORT TONS)</u>	<u>\$ VALUE (MILLIONS)</u>
JAN 74	18,538	33.4
FEB	18,116	32.6
MAR	15,593	28.1
APR	14,100	28.2
MAY	13,714	27.4
JUN	13,500	27.0
JUL	13,206	29.1
AUG	13,888	30.6
SEP	14,100	31.0
OCT	9,238	21.7
NOV	10,350	24.3
DEC	9,610	22.6
JAN 75	17,019	40.0
FEB	11,200	26.3
MAR	15,585	38.9
1-17 APR (EST)	<u>8,500</u>	<u>21.2</u>
TOTAL	216,256	\$462.4 MILLION

\* From in-country receipt depots:  
 Phnom Penh Depot Complex  
 Battambang  
 Siem Reap  
 Kompong Som

AMMUNITION MANAGEMENT - INSPECTION AND ANALYSIS

1. GENERAL.

a. During early 1974, increasing rates of ammunition expenditure and rapidly escalating munitions costs combined to consume over 80% of every MAP-CB dollar. To reduce waste and loss through improper storage and conserve dwindling MAP dollars, CHMEDTC, in May 1974, directed establishment of a comprehensive End-Item Utilization Inspection (EIUI) program. EIUI's were tailored specifically to ascertain proper storage, receipt, accountability, and utilization of MAP-provided munitions. Initially, EIUI's were conducted five days per week and concentrated on a total of fifteen selected enclaves. As the program gained momentum, the number of locations increased to thirty-one. In November 1974, after an evaluation of EIUI results, a decision was made by CHMEDTC to reduce EIUI's to three per week. The rationale supporting this decision was the level of improvement observed at a majority of the locations visited, the requirement to spend more time in analyzing inspection data, and renewed efforts to encourage FANK senior officers to take a more active interest in ammunition management. All EIUI's were discontinued on 2 April 1975, when the deteriorating tactical situation around the capital dictated a drastic reduction of the U.S. mission personnel in-country.

b. CHMEDTC in May 1974, initiated a vigorous program to conserve ammunition and reduce the expenditures, coincident with the commencement of the EIUI program. The goals of the conservation measures were to: (1) reduce expenditure rates; (2) minimize loss from poor storage and handling; and (3) provide data of actual expenditure rates to allow the resupply of required ammunition in appropriate quantities. Through the combined efforts of EIUI's, data analysis, and introduction of Third Country National (TCN) specialists, improvements were observed; however, they were only marginal due to a lack of FANK support at the higher echelons. In December 1974, CHMEDTC decided that drastic measures were needed to realign the FANK ammunition logistics system to eliminate or reduce the unnecessary drain on scarce ammunition assets. On 24 December 1974, CINCFANK approved a MEDTC-conceived plan to centralize all ammunition functions under one office. The key points of the plan included: (1) elimination of previous multiple channel access to FANK ammunition functions by the establishment of a single office through which all ammunition actions flowed; (2) provision of absolute authority to the Assistant Chief of Staff (AC of S), Munitions for issues, receipts, stock control, priorities, and special requirements; (3) development of a country-wide reserve under the AC of S, Munitions control, which would be used to meet tactical contingencies; (4) imposition of a strict allocation program which provided set limits (in rounds by type of ammunition) for daily issues and established specific limits for total rounds authorized on-the-ground for units and enclaves; and (5)

strategic placement of TCN's at locations where they could monitor and assist FANK in the implementation and overall functioning of the plan. FANK implemented the plan on 1 January 1975.

c. Both the EIUI program and ammunition conservation plan grew out of the necessity to impose tighter controls on expenditures of MAP-CB provided munitions. The focal point of both these schemes was a comprehensive system of expenditure analysis which permitted daily accounting of units and enclaves keyed to the intensive management of the highest use and most expensive munitions. Prior to and during the initial phases of the EIUI program, country-wide comparisons between units/enclaves were made by applying a series of "required supply rates" (RSR). The RSR's were prepared in coordination with CINCPAC and consisted of numerical analysis of combat intensity factors, country-wide weapons densities, dollar constraints, and prior expenditure data. Authorized supply rates (ASR) developed in-country relied on prior experience data and were used as a basis for the preparation of call forwards. The goal was to hold the Khmer Armed Forces to expenditures at ASR while ordering at a planning factor of 30 days at RSR to build contingency stocks. (RSR was approximately two times the ASR). After careful analysis and application, it became apparent that the RSR system for the management of munitions expenditures was not adequate in a rapidly changing combat environment because it tended to place undue restrictions on combat units. Conversely, the ASR was found to provide a workable data base for call forwards when combined with expenditure data. In October - November 1974, the RSR's were replaced by a laborious but more accurate system of detailed expenditure analysis. Daily reports received through FANK and TCN channels were compared with previously obtained data to establish expenditure trends consistent with the tactical situation. EIUI's were conducted at selected locations more frequently to obtain short term trends and provide a collection vehicle for weapons densities and local commanders' assessments of munitions requirements as well. This new data base, updated daily, thus became the overall munitions management tool for the resupply of munitions to FANK. In January 1975, with the advent of the new FANK Ammunition Conservation Program, the data base previously developed was adjusted to conform to dollar constraints of \$650,000 per day and units were allocated munitions based on tactical priorities. The FANK Ammunition Conservation Program was successful; it reduced expenditures without adverse impact on combat effectiveness and in spite of an ever-increasing level of combat intensity. It should be stressed that units and enclaves were observed carefully to insure on-hand stock status did not drop below critical levels. Reports were received through Khmer channels which indicated zero balances; however, on-site inspections verified that this reported condition tended to indicate rather a two-or three-day level of supply in the hands of troops with a near-zero balance in regional or forward depots.

2. EIUI's. Conduct of EIUI's was governed by MEDTC Memorandum, with the

stated purpose of determining whether MAP-provided assets were being properly cared for and utilized. Joint FANK/US/TCN inspection teams performed these inspections on a frequency determined by the condition of munitions with a view toward determining adequacy of munitions facilities, records, procedures, personnel training, and command responsiveness. Recommendations were given on-the-spot for suggested improvements, and followup reports written on return of the team. A location showing a trend of unsatisfactory performance was scheduled for an inspection every four weeks. Units/locations in the Satisfactory to Excellent category were inspected every 6 - 16 weeks. In those instances where increased tactical activity required intensive management of munitions assets or reporting was suspect, more frequent inspections were made. Additionally, numerous unscheduled and unreported inspections were conducted to assess the status of national reserves, depot construction, confirm questionable stock status reports of units and enclaves and gather data to be used to prepare requests for air and ground resupply of munitions to in-country major supply points (Kantauk Depot, Battambang, Kompong Som). These inspections were unannounced and usually in coordination with the FANK Ammunition Control Office. Findings were often the basis for rapid decisions concerning the resupply of engaged tactical units. The type of data collected by EIUI teams generally consisted of the following: weapons density reports, munitions stock status, receipts, issues, and changes since the previous inspection. Where possible, physical inventories were conducted to verify reports and to determine whether units and enclaves were applying proper ammunition management techniques. Time permitting, teams also attempted to collect data pertinent to the tactical situation, vehicle status, medical, food (rice), and other areas of interest. The data obtained by EIUI was one of the most valuable assets to the ammunition management program, primarily because FANK reports and reporting systems were not timely and reports generally were inaccurate. Field data as collected and verified by on-the-spot inspections thus became the most accurate data base for FANK and MEDTC use in determining munitions requirements. This data base was used extensively during the organization and functioning of the new FANK Ammunition Conservation Program (1 January 1975). During the period 1 May 1974 through 2 April 1975, a total of 215 ammunition EIUI's were performed throughout the Khmer Republic (See TAB A).

3. AMMUNITION CONSERVATION. FANK had progressed through a series of trial-and-error programs in early-to mid-1974 while trying to achieve a sound ammunition management program. The cause of the problem had been the decentralized and multilayered organization referred to as DIRMAT (Director of Materiel). DIRMAT, in theory, controlled munitions functions under the umbrella of the FANK J-4. In reality, however, major decisions involving priorities, allocations and special requests were dictated by the J-Staff or higher level. DIRMAT thus became and functioned as a "clearing house" for orders and decisions passed from these channels and had very little influence over the management

of munitions. In consequence, munitions assets were being rapidly depleted, expenditures were increasing without a significant improvement in tactical posture, and units or enclaves were being shorted on munitions allocations to fill the stocks of "favorite son" organizations. After repeated attempts to rectify and improve ammunition management, without appreciable results, CHMEDTC in December 1974 directed the development of a new organization which would centralize ammunition management functions and eliminate the existing ineffective system. The new organization was titled "The Joint Ammunition Control Office" (later FANK named it Director of Munitions), came under the direct operational control of the FANK Commander-in-Chief, and was headed by a general officer. CINCFANK approved the MEDTC-conceived plan on 1 January 1975, and implemented it on the same day. Initially it was anticipated that FANK would be able to have the office fully functional in thirty days; however, the 1 January 1975 Dry Season Offensive frustrated these plans. Throughout the month of January and into mid-February, munitions assets and functions were administered by "crisis management" and it was not until mid-to-late February that operations approached normalcy. This period of "crisis" helped rather than hindered the development of a cohesive organization which could operate under the most trying of circumstances. The most important contribution of the Director Munitions (DIRMU) was its elimination of the J-Staff multi-access to munitions assets. The Director, being of equal rank with most J-Staff Heads, was able to develop a semblance of rapport that permitted more stringent controls over the distribution of munitions. Additionally, a system of country-wide allocations accompanied the original plan which forced unit commanders to "intensively manage" their own expenditures. These allocations were, in turn, keyed to the MAP-CB purse string, which permitted a daily dollar expenditure of \$650,000 for all munitions. For the purpose of contingencies or special operations, a reserve was created that was controlled by the Commander-in-Chief; however, this authority was delegated to the Director, DIRMU, and proved very successful. The DIRMU functioned quite effectively through-out the Dry Season Offensive and was able to maintain expenditure rates at acceptable levels. All functions terminated on 17 April 1975.

4. EXPENDITURE ANALYSIS. Between May and December 1974 analyses of expenditures, reporting of stock status and related management functions were heavily reliant on feedback from EIUI's and TCN's because FANK reporting was generally falsified, late, and not in sufficient detail for thorough analyses. The major stumbling block had been the DIRMAT organization because of its fragmented functions; however, units and enclaves were also major offenders and suffered from a lack of firm leadership. Comparisons of required supply rates (RSR's) had been the major mode for determining unit and enclave requirements for resupply of munitions, computation of expenditures, and determination

of trends. However, the RSR methodology was heavily dependent on the frequent conduct of EIUI's for accurate data and assumed expenditure rates based on prior years of experience. This latter characteristic was found to be a false premise, since prior years' experience had been determined during periods of relatively low combat intensity. Thus, during 1974, a year after the cessation of massive U.S. Air Support, FANK faced a new set of parameters on the battlefield that significantly increased reliance on its own firepower and resulted in dramatically higher expenditures of ground munitions. In order to maximize every MAP dollar and retain a strong fighting posture, in December 1974, CHMEDTC directed the development of a new "hard line" ammunition conservation program which could support FANK's battlefield requirements. Of paramount importance to the new program was a method of determining actual combat needs keyed to MAP dollar constraints. The system developed met these goals and consisted of a detailed set of allocations and national reserve. Allocations were derived by a comparison of weapons densities country-wide, estimates of daily requirements for each type munition, and, finally, the application of costs versus requirements to arrive at the optimum mix of munitions possible. Once the total daily allocation was established, a percentage (5 - 10%) was deducted to form the daily national reserve. The next set of calculations involved the distribution of the daily allocation (less reserve) among units and enclaves country-wide. This was accomplished by establishing a set of four priorities, in numerical equivalents, then assigning each unit/enclave a priority based on tactical considerations submitted by the J-3 (Ops). The priorities were such that if a unit/enclave received an increased priority, another less threatened unit/enclave received a proportionally reduced priority to balance total allocations. Multiplication of a priority factor times the weapons density for a specific munition resulted in the unit's/enclave's allocation for that type munition. To meet the changing tactical situation it was necessary to compute new unit/enclave allocations each month and occasionally more frequently; however, these changes were simple and readily applied by FANK once the initial massive calculations were complete. The allocation and priority system was highly successful and helped reduce expenditures from an average high of 600 short tons per day in January 1975 to an average 400 short tons per day in February 1975, without a detrimental impact on combat capability. Additionally, commanders of units and enclaves readily supported the system once they saw it was responsive to their combat requirements. Prudent use of the national reserve helped to reinforce this unit confidence. TAB C contains examples of reporting and computations formats for the allocation system.

## 5. CONCLUSIONS.

a. Both the End Item Utilization Inspection and Ammunition Conservation programs were successful in accomplishing the goals for which they were intended. Each sought to improve the utilization of munitions

assets severely constrained by Military Assistance Program (MAP) funding levels and thereby to enhance the combat effectiveness of the Khmer Armed Forces. At no time during the administration of either program was it apparent that units/enclaves were unable to perform combat missions due to shortages of munitions; however, this excuse was often used by certain commanders who obviously lacked leadership qualities.

b. Throughout the 1974-1975 time frame the Khmer Armed Forces continually faced the uncertainty of dwindling MAP funds and the high probability that the U.S. Congress might discontinue or drastically reduce the MAP-CB program. This had a negative psychological impact on senior Khmer military leadership, but it did serve as an impetus to some to realize the need for an ammunition conservation program.

c. Analysis of data was an important aspect of both the EIUI and Conservation programs and progressed through several generations of changes to meet the needs of the Khmer Armed Forces. Each revision proved more workable than the previous one, so that, by January 1975, the system was as responsive as could be expected within the limited Khmer and US assets available.

d. Of paramount importance in a rapidly changing tactical environment, such as Cambodia, is a means to rapidly receive, assimilate, and analyze munitions management data. In the five short years of the Khmer military and MEDTC history it was not possible to develop a time-sensitive, responsive system.

e. Congressional constraints on MEDTC personnel and incremental releases of MAP funds hindered the effective management of this high dollar item.

SUMMARY OF EIUI'S COMPLETED

1 May 74-2 Apr 75

<u>LOCATION</u>	<u>AVERAGE FREQUENCY OF INSPECTION (WEEKS)</u>	<u>TOTAL NUMBER OF INSPECTIONS PERFORMED</u>
<u>ENCLAVES</u>		
BATTAMBANG	6	11
DAS KANCHOR	6	3
KAMPOT	5	8
KOH KONG	8	5
KOMPONG CHAM	6	8
KOMPONG CHHNANG	6	9
KOMPONG SOM	6	11
KOMPONG SPEU	5	7
KOMPONG THOM	5	13
KRAKOR	16	1
LOVEK	4	13
NEAK LOEUNG	5	9
ODDAR MEANCHHEY	6	3
OUJONG	5	2
PAILIN	16	1
PREY VENG	4	16
PURSAT	6	8
SIEM REAP	5	8
SVAY RIENG	5	13
TAKEO	4	12
THMAR PUOR	16	1
(21)		
<u>TACTICAL UNITS</u>		
1st DIVISION	5	9
2nd DIVISION	5	8
3rd DIVISION	5	9
7th DIVISION	5	9
9th DIVISION	5	3
1st PARA BDE	12	3
ARMOR BDE	12	1
SPECIAL MILITARY REGION	5	8
(8)		
<u>SPECIAL LOCATIONS</u>		
POCHENTONG AIR BASE	8	3
KHMER NAVY BASE	8	1
TOTAL (31)		TOTAL 215



#### MISSION

To perform End-Item Utilization Inspections (EIUI's) of selected locations in the Khmer Republic for the purpose of ascertaining proper storage, receipt, accountability, and utilization of MAP<sup>2</sup>-provided munitions.

#### SCOPE

End-Item Utilization Inspections apply primarily to Army munitions (ground munitions); however, inspections are inclusive of MNK (Navy) and KAF (Air Force) munitions when co-located with Army munitions. Separate inspections of MNK and KAF facilities are scheduled as required to determine adequacy of facilities and proper storage of munitions.

#### LOCATIONS

There are presently thirty-one (31) selected locations where EIUI's are conducted. Time between inspections varies from every four weeks (for locations exhibiting high consumption rates due to combat activity) to sixteen weeks for locations where combat activity is low. Each of the Military Regions, the Special Military Region, Divisions, Phnom Penh proper, and separate brigades are included in the list of selected locations. In coordination with the other MEDTC divisions, EIUI's are scheduled to units or locations not contained on the "selected" list; e.g., brigades, training centers, special enclaves. Selection of locations is predicated on the necessity for inspections of MAP-supported materiel and safety of personnel performing EIUI's.

#### DATA COLLECTION

The data collected during EIUI's provide the basis for: the preparation of recommendations to FANK for the correction of deficiencies, computation of requirements for resupply of munitions through U.S. logistic channels, determination of consumption rates, assessment of weapons densities, requirements of days of supply (DOS) in-stock, and other computations relating to the supply and consumption of munitions.

Information is also gathered for the purpose of making estimates and recommendations for facility improvement, expansion, or new facility construction.

END-ITEM UTILIZATION INSPECTION  
LOCATION MAP-CAMBODIA

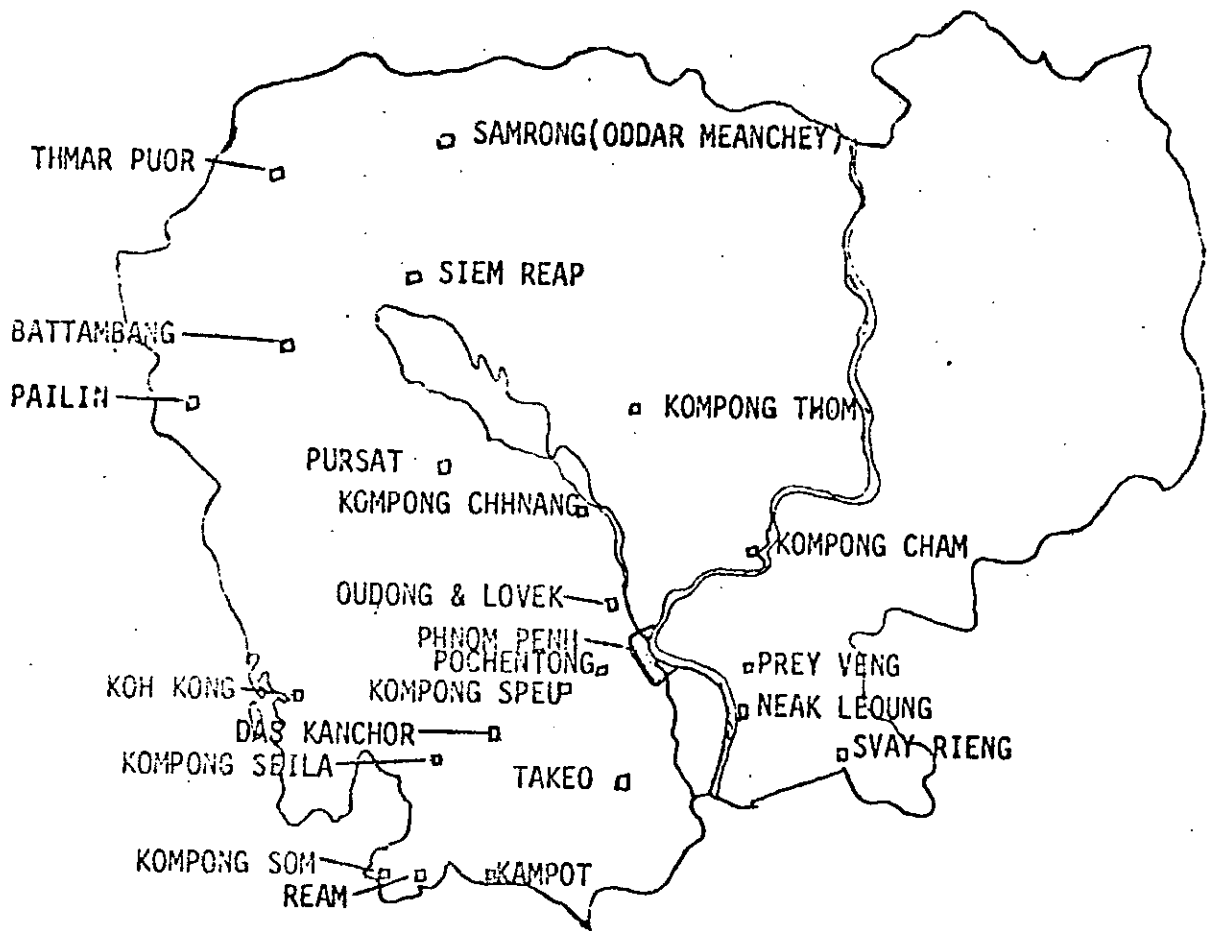

FANK Daily and Weekly Reports

Inspection Visit & Reports

TCN Reports

Receipt and Recording of Information

Computation of Daily Consumption

Monitoring of Stock Status On-Hand & Projected

Monitoring of Critical Supply Items

Analysis and Discussion

Discussions with and Training of FANK Ammo Personnel and Commanders to Improve FANK Procedures

Recommendations to FANK Joint Transportation Board for Intra-Country Movement

Recommendations for Calls Forward of Shipments from Outside Sources to One of 4 Receiving Points

Recommendations for Amount and Type Mix for C-130 Air-drops

Feedback of Problem Areas for Future EIUI's

THE FOLLOWING GUIDELINE OF GROUND MUNITIONS EXPRESSED IN AMOUNT/TONNAGE/COST  
WILL BE USED FOR CONSERVATION EFFECTIVE 1 JANUARY 1975 :

DODIC	NOMENCLATURE	ALLOCATION	TONNAGE	COST	AMOUNT OF TOTAL ALLOCATION DE- VOTED TO NATIONAL RESERVE
A071	5.56 Ball	742,445	14.85	59,395.60	70,000
A131	7.62mm Linked MG	47,928	2.40	7,668.48	6,000
A181	.30 Cal Ball	60,065	1.20	4,805.20	10,000
A218	.30 Cal Linked MG	106,860	5.34	19,234.80	12,000
A534	.50 Cal Linked MG	37,000	7.40	14,060.00	2,923
B568	40mm HE	10,200	3.98	36,720.00	1,103
B627	60mm Ill	247	.92	3,877.40	25
B632	60mm HE	4,757	13.03	64,600.06	700
C226	81mm Ill	168	1.61	8,354.64	80
C256	81mm HE	2,046	19.03	56,878.80	300
C445	105mm HE	4,330	129.55	154,581.00	704
C449	105mm Ill	98	2.94	7,364.70	40
C650	106mm HE	109	3.37	14,833.81	20
C704	4.2 HE	50	1.07	3,729.50	13
D541	Prop (WB)	228	3.09	7,619.76	20
D544	155mm HE	228	11.36	13,750.68	20
G881	GREN Frag	1,470	1.28	4,189.50	600
H555	LAW RKT 72mm	54	.21	2,231.28	35
K143	Mine, Claymore	349	1.54	8,547.01	100
L495	Flare Trip	426	.38	2,947.92	100
N335	Fuze PD	4,527	8.33	36,804.51	773
N525	Primer	228	.01	111.72	20
			232.89	\$ 532,306.87	

THE FOLLOWING GUIDELINE FOR AIR MUNITIONS EXPRESSED IN AMOUNT/TONNAGE/COST  
WILL BE USED FOR CONSERVATION EFFECTIVE 1 JANUARY 1975 :

DODIC	NOMENCLATURE	TOTAL DAILY ALLOCATION	TONNAGE	COST
A165	7.62mm Mini Gun	50,000	2.00	7,500.00
A919	20mm HE	3,220	1.51	5,924.80
E148	Bomb, 500lb NAP	32	8.94	7,495.92
E196	Bomb, Cluster Frag	45	7.31	7,463.70
E485	Bomb, 500lb HE	100	28.44	32,165.10
H490	RKT HE 2.75	400	6.81	28,212.00
H519	RKT SMK 2.75	30	.50	2,443.20
L419	Flare Acft	24	.30	808.32
	All items expressed in complete round		55.81	\$ 92,013.04

Total daily tonnage ----- 288.70  
 Total daily cost of munitions-----\$624,319.91  
 Dollar value reserved for purchase of  
 line items not here shown-----\$25,680.09  
 Total daily budget-----\$650,000.00

PRIORITY GUIDE

THESE FIGURES TIMES WPNS DENSITY GIVE DAILY ALLOCATION

<u>DODIC</u>	<u>NOUN</u>	<u>PRIORITY 1</u>	<u>PRIORITY 2</u>	<u>PRIORITY 3</u>	<u>PRIORITY 4</u>
A071	5.56 Ball	5	4.5	4	3
A131	7.62 MG	31	29	27	25
A181/2	30 Cal Carb	2	1.75	1.5	1
A218	30 Cal MG	24	22	20	18
A534	50 Cal MG	31	29	27	25
B568	40mm GREN	0.8	0.7	0.6	0.4
B627	60mm Illu	0.15	0.125	0.1	0.05
B632	60mm HE	2.6	2.2	1.9	1.6
C226	81mm Illu	0.15	0.125	0.1	.05
C256	81mm HE	2.6	2.2	1.9	1.6
C445	105mm HE	19	16	13	10
C449	105mm Illu	0.4	0.3	0.2	0.1
C650	106mm RR	1.1	1	0.9	0.8
C705	4.2" HE	2.6	2.2	1.9	1.6
G881	GREN FRAG	14	12	10	8
H557	66mm RKT	0.3	0.275	0.25	0.2
K143	Mine APER	4	3.5	3	2
L495	Flare Trip	5	4.5	4	3

APPENDIX 3 TO ANNEX E

AERIAL RESUPPLY

1. GENERAL.

a. Airdrops began on 19 June 1972, when four C-130 sorties of ammunition were delivered to Svay Rieng. Initially missions were flown out of Tan Son Nhut, RVN and U-Tapao, Thailand. Only in March 1973 did all missions originate solely from Thailand. In 1972, 133 missions were flown which represented 2,128 Containerized Delivery System (CDS) bundles or the equivalent of 1,993 short tons. Tab A gives complete month-by-month listing of airdrop tonnages for Project SCOOT (Support Cambodia Out of Thailand) between 1 January 1974 and 17 April 1975.

Air delivery of MAP-CB ammunition and USAID rice was performed by USAF C-130 aircraft. Commencing in October 1974, the C-130 aircraft were operated by civilian crews who were employed by Bird Air under the terms of a service contract. The air delivery role for the Khmer Republic fluctuated with the level of combat intensity and was proportionately higher during the Dry Season, when surface transportation by water and land was easily interdicted by the Khmer Rouge (KC).

b. Operations in Southeast Asia have played a major role in the development of high-altitude airdrops. The Cambodian airdrops are unique, because for the first time aircraft employed the Adverse Weather Aerial Delivery System (AWADS) and Station Keeping Equipment (SKE) for high-velocity Containerized Delivery System (CDS) airdrops from 12,000 feet. The drops were made using a 26-foot ring-slotted parachute and individual CDS bundles that weighed 1,800 - 2,000 pounds. Rigging procedures for the CDS method of delivery were as prescribed in appropriate Army rigging manuals. Bundles were assembled and parachutes installed by qualified U.S. Army parachute riggers. A normal C-130 load averaged 14.2 short tons, consisting of 16 CDS bundles.

2. AIR DELIVERY PROCEDURES AND PROBLEM AREAS.

a. Bundles dropped into Cambodia contained either ammunition or rice and were rigged to sustain a high-velocity ground impact of 70 to 90 feet per second. Rigging was accomplished in accordance with the guidelines presented in TM 10-500-1/T.O. 13C7-1-11 and TM-500-53/T.O. 13C7-18-41. All cargo was rigged utilizing a standardized "honeycomb sandwich kit". The kit consists of a 48"x53 1/2" 3/4" plywood skidboard, to which are attached 5 layers of 48-inch square energy -dissipating padding (honeycomb), the A-22 harness and sixth layer of honeycomb which serves as the sandwich top. The sandwich is bound together by

5/8" steel strapping. The remaining kit components are a 26-foot ring slot parachute, A-22 cargo bag cover, and additional honeycomb for internal cargo restraint.

b. The malfunction rate for the high-velocity CDS mode of delivery from 12,000 feet was 5.4 percent. This is somewhat higher than the 1 to 2 percent acceptable rate for a standard low-velocity airdrop. A study in July 1974 (13th AF Investigation/Analysis of SEA Hi-altitude Airdrop Malfunctions) was conducted and recommended several changes. A CONUS test is currently being planned which should aid in lowering the malfunction rate.

Malfunctions were grouped into two areas. The first is the Type 26 release gate. The CDS release gate is a nylon strap drawn around the back side of the load. It is cut by a knife attached to a motor-actuated cable which is engaged at the desired release time (green light). The nose-high attitude of the aircraft at drop and airspeed/flap setting allows the load to freely exit the aircraft under gravity force. High-speed movies show this "cutting action" to be irregular, not allowing the bundles to exit the aircraft at a uniform rate and time. A CONUS study is being conducted to convert the Type 26 release gate to a pyrotechnical cutting device that would be activated instantaneously by the navigator. The second, and most common, malfunction was the streamer. The primary cause seemed to be parachute/suspension line damage. Based on high-speed movies, it was discovered that parachute deployment actually occurs inside the rear portion of the plane's fuselage. The chute is often "whipped" against the aircraft and suffers damage. During chute deployment, the chute canopy drops or drags over the preceding load due to the closeness of one load to another. Load tumbling occurs outside the aircraft which can damage suspension lines. Load collision also occurs during descent, which causes damage to lines and canopies. These problems are being studied at Natick Laboratories and hopefully a solution can be found to reduce the CDS streamer rate.

### 3. OPERATIONS AND PLANNING.

a. Requesting an airdrop consisted of a coordinated plan between the MEDTC airdrop officer and the USAF ALCC detachment in Thailand. A request was received from FANK or was generated internally from a MEDTC/US Embassy element (as in the case of rice). Based on available resources, a coordinated MEDTC/FANK decision was made and the operation would be approved or denied. Once an operation was approved, a message was sent out describing the location, type and amount to be dropped, and when the drop was required. Some operations consisted of hundreds of short tons and continued for several weeks.

b. In addition to the special airdrop message request, coordination was made by phone to direct bundle configurations and specific drop items. A standard 16-bundle ammo load was designed that would meet the requirements

of most FANK units. The load consisted of the following items:

105mm HE	8 BUNDLES	240 RDS
81mm HE	3 BUNDLES	270 RDS
60mm HE	1 BUNDLE	288 RDS
40mm	1 BUNDLE	2,160 RDS
5.56mm	1 BUNDLE	43,360 RDS
.30 Cal MG	1 BUNDLE	20,000 RDS
105mm Fuses & 5.56mm	1 BUNDLE	240/23,520 RDS

A rice bundle consisted of 1,800 pounds of rice. A 16-bundle plane load carried 28,800 pounds (14.4 S/T) of rice.

Standard bundles for various types of ammunition were developed which provided an easy and efficient method of designing a 16-bundle plane configuration and maintaining accurate accounting of munitions.



TAB A TO APPENDIX 3 TO ANNEX E

CONSOLIDATED LISTING OF AIRDROPS FOR  
PROJECT SCOOT

<u>MONTH</u>	<u>AMMO TONNAGE</u>	<u>RICE TONNAGE</u>	<u>TOTAL TONNAGE</u>
1974			
JAN	628	730	1,358
FEB	694	237	931
MAR	992	781	1,773
APR	3,608	1,051	4,659
MAY	2,086	1,103	3,194
JUN	2,236	857	3,095
JUL	1,127	594	1,716
AUG	679	300	979
SEP	592	307	899
OCT	527	290	817
NOV	605	346	951
DEC	571	255	826
	<u>14,340</u>	<u>6,858</u>	<u>21,198</u>

1975			
JAN	381	141	522
FEB	382	0	382
MAR	2,426	614	3,040
APR (1-17)	950	1,022	1,972
	<u>4,139</u>	<u>1,777</u>	<u>5,916</u>

APPENDIX 4 TO ANNEX E

POL

1. GENERAL. MAP-CB provided FANK with four bulk petroleum products (automotive gasoline - MOGAS; diesel fuel - ADO; aviation gasoline - AVGAS 115/145; and jet fuel - JP-4) plus ten packaged products (oils, lubricants and greases). Approximately 13.3 million MAP-CB dollars were committed to purchase these products during the period 20 February 1974 to 17 April 1975.

2. REQUISITIONING PROCEDURE. FANK POL was requisitioned by MEDTC from the Defense Attache Office, Saigon, RVN (DAO SGN). The quantities required by FANK were included in contracts for the Republic of Vietnam Armed Forces negotiated with commercial Southeast Asian oil firms (Shell, Caltex and Esso) by DAO SGN. Financial reimbursement was effected by DAO SGN following a series of transactions involving CHMEDTC; Minister of National Defense, GKR; Minister of Defense, RVN; and the US Army International Logistics Center, New Cumberland, Pa. Title transfer for the product occurred at the point of tanker loading, ie., Nha Be or Vung Tau, RVN. The requisitioning system proved to be very effective. DAO SGN and USAILC were cooperative, responsive and professional. Until the interdiction of the Lower Mekong in January 1975, the supply of POL from RVN was regularized, consistent and uninterrupted.

3. COST OF FUEL. Fuel costs escalated dramatically during the February 1974 - April 1975 time frame (See Tab A). Prior to February 1974, MEDTC had obtained FANK POL from Defense Fuel Supply Center (DFSC) sources. However, as a result of the Arab oil embargo, DFSC supply of POL to Southeast Asian MAP countries terminated in January 1974. In order to insure the supply of POL for FANK, MEDTC entered into the RVNAF contracts negotiated by DAO SGN. As shown below, rising fuel costs contributed significantly to the annual budgetary increases required to support the MAP-CB program, with little craft/vehicle/air-frame increases.

MAP-CB BUDGET

<u>FISCAL YEAR</u>	<u>\$ BUDGETED</u>
1974	\$8.9 MILLION
1975	\$10.9 MILLION
1976	\$19.9 MILLION

4. TRANSPORTATION. POL entered Cambodia at one of three locations: Phnom Penh, Kompong Som and Battambang. Product was transported to Phnom Penh and Kompong Som via ocean tanker from RVN and overland by tank truck from Thailand to Battambang. The ocean tanker fleet, contracted by Tela Khmer (the Khmer National Oil Company) with USAID

funds, was composed of nine antiquated and poorly maintained Korean and Panamanian vessels. The crews, principally Vietnamese, Filipinos and Koreans, were not seamen by trade. Their selection was based primarily upon a willingness to risk the hazardous Mekong voyage. Antiquated vessels and non-professional crews contributed significantly to an in-transit fuel loss rate that exceeded allowable DOD standards. The movement of the product from RVN to Phnom Penh and Kompong Som was planned and coordinated by a joint committee chaired by the MEDTC POL Officer and comprised of representatives of Tela Khmer, Shell, the FANK Diressence (POL Directorate), KAF and MNK. The cooperation and positive attitude displayed by the Khmer military and civilian agencies resulted in a smoothly functioning and highly effective committee. The work of Mr. Khing Tayky and Mr. Cher Tim of Tela Khmer, Mr. Huor of Shell and Colonel Var Chhom and Lt Seng Saranak of FANK was particularly praiseworthy. The committee planned and coordinated the movement of approximately 8,650 cubic meters of bulk POL per month to Phnom Penh and Kompong Som during the period 20 February 1974 - 31 December 1974. Approximately 95 percent of this was moved up the Mekong River to Phnom Penh. This average dropped drastically during the first three months of 1975 because of the interdiction of the Mekong. TAB B contains a by-month presentation of this data. Product delivered to Battambang was civilian owned (ground fuels by Tela Khmer; aviation fuels by Shell of Cambodia). FANK and KAF utilized this fuel in Battambang, Pursat and Siem Reap. At the end of each month, reimbursement in kind was made to Tela Khmer and Shell from military stocks stored in Phnom Penh.

5. MONTHLY ALLOCATIONS. Each month MEDTC allocated bulk and packaged POL to FANK in quantities commensurate with projected requirements. As indicated below, Dry Season allocations were normally much higher than those for the Wet Season.

MONTHLY BULK POL ALLOCATIONS  
(IN CUBIC METERS)

<u>PRODUCT</u>	<u>WET SEASON ALLOCATION</u>	<u>DRY SEASON ALLOCATION</u>
AVGAS 115/145	1,700	2,400
JP-4	800	1,200
MOGAS	2,000	2,200
ADO	3,200	3,500

It was the responsibility of the FANK Diressence to sub-allocate the quantity provided by MEDTC to the Khmer Army, Navy, and Air Force. Allocations for MOGAS and JP-4 were seldom exceeded. However, requests were frequently submitted for supplemental ADO and AVGAS allocations.

6. STORAGE. FANK depots were utilized for the storage of the greater portion of military POL. The Diressence operated thirteen depots for the storage of ground fuels. The largest of these was the modern Prek Phnau facility, located approximately 16 kilometers north of Phnom Penh on the Tonle Sap River. This depot contained 80 percent of FANK's ADO storage capacity and 75 percent of its MOGAS capacity. In late January 1975, the Prek Phnau complex was exposed to both direct and indirect fire from KC units operating in that area. Therefore, approximately 95 percent of the bulk and packaged POL was moved to the more secure Tela Khmer, Shell and COMIN depots located 12 kilometers south of Prek Phnau. Aviation fuels were stored in six KAF depots; however, Shell's Phnom Penh facilities were utilized to store approximately 75 percent of KAF AVGAS and JP-4. MNK stored ADO in seven different locations. Depots outside of Phnom Penh possessed a variety of storage containers: drums, bladders, railway tankers, barges, small steel tanks issued by the French Army and US military permanent steel tanks. During the period February 1974 to April 1975, permanent steel tanks with a total capacity of 3,000 cubic meters were erected at Battambang, Kompong Som, Kompong Chhnang and Phnom Penh. A matrix at TAB C shows the locations of Khmer military POL depots.

7. DIVERSION OF FUELS. MEDTC faced a continuing challenge in attempting to insure the proper utilization of MAP-CB-provided fuels. Fuel was a highly marketable commodity and members of the Khmer military could significantly supplement their paltry income by selling or utilizing military petroleum products. A DSAA audit, requested by CHMEDTC in March of 1974, revealed a misappropriation of AVGAS by KAF totalling \$310,000. Reimbursement to the U.S. government was formally requested of the Prime Minister, GKR. On 21 May 1974, the GKR presented the US mission with a check for this amount which was subsequently deposited with the US Treasury. In order to prevent future diversions of AVFUELS, CHMEDTC directed the establishment of a Joint Aviation Fuels Control Board (JAFCB) and the initiation of an into-plane refueling service (IPS). The JAFCB, chaired by the MEDTC POL Officer and comprised of representatives from KAF, FANK, GKR-MINDEF and Shell, met monthly. It reviewed data on KAF flying hours, fuel consumption and aviation fuel allocations. The into-plane refueling service, initiated on 26 August 1974, is discussed in detail in the succeeding paragraph. These two actions, creation of the JAFCB and initiation of the IPS, resulted in a significant reduction in aviation fuel losses. Diversion of AVGAS and JP-4 approximated \$112,000 per month for the period October 1973 through May 1974. However, from June 1974 through February 1975, this figure was reduced to approximately \$8,100 per month. TAB D shows a monthly listing of aviation fuel losses for the referenced period. Although small-scale diversions were never stopped, as evidenced by the fact that one liter bottles of gasoline were being sold on Phnom Penh streets as the final group of Americans evacuated that city, major diversions were eliminated.

8. INTO-PLANE REFUELING SERVICE. The into-plane refueling service of KAF aircraft commenced, under the terms of a MEDTC/Shell contract, on 26 August 1974. The contract was negotiated for the US government by contracting officers of the Bangkok Procurement Activity, US MACTHAI Support Group. Annual contract cost was estimated at \$420,000. Although billing has not yet been completed, it appears that the actual cost will not exceed \$150,000. Shell refueled both fixed-wing aircraft and helicopters on a 24-hour basis at Pochentong Airfield. Fuel was also dispensed into 500-gallon bladders and 55-gallon drums for KAF delivery to outer bases. Shell utilized 35 people in the operation with the workload divided into two 12-hour shifts. The majority of the government-furnished refueling vehicles and trailers were in a substandard maintenance condition. The major problems faced during the operation were the animosity directed toward the Shell staff by many KAF personnel and the lack of repair parts and spares (most notably tires, clutch-plates and filter separator/meter components) for disabled vehicles. Despite these factors, the Shell staff provided outstanding service. Their performance during the KC offensive, when Pochentong airfield came under continuous rocket fire, was particularly noteworthy. Several Shell employees were wounded, four of them seriously; two men were honored by Ambassador Dean for acts of heroism.

9. FUEL SAMPLE TESTING. A laboratory for conducting required aviation fuel tests was not available in Cambodia. Therefore, fuel samples were dispatched, via aircraft, to U-Tapao airbase and subsequently tested at the USMACTHAI Support Group laboratory at Camp Samae San, Thailand. The personnel at this facility often worked on weekends and holidays to expeditiously complete the required testing. During the period 20 February 1974 thru 11 April 1975, the Samae San laboratory tested 212 aviation fuel samples.

10. KHMER MILITARY AND CIVILIAN POL PERSONNEL. Generally, the key Khmer military and civilian POL personnel were eminently qualified to perform the POL support mission. Colonel Var Chhom (promoted to that rank during the final weeks of the war), the FANK Diressence, was a true professional. Trained in both French and US military schools, he possessed a wealth of POL knowledge and experience, cooperated with both MEDTC and the Khmer civilian POL agencies and maintained a highly effective directorate. Since only two officers per year were allocated training spaces at Fort Lee, Colonel Var Chhom organized a very productive officer/NCO training program with Shell Corporation in Phnom Penh. KAF did not possess a Petroleum Officer of Colonel Var Chhom's caliber; this had an adverse effect upon the quality of their POL operations. MNK, with a miniscule POL mission, did not have an officer responsible solely for petroleum functions. Khmer military and civil POL agencies interfaced well in planning and coordinating the receipt, storage and distribution of POL products. Mr. Kunthap Hing of Shell and Mr. Khing Tayky of Tela Khmer rendered invaluable support to both MEDTC and the Khmer military.

11. POL LIAISON VISITS. The MEDTC POL Officer and TCN POL Specialist conducted 32 visits to FANK, KAF and MNK POL depots and facilities during the period 3 June 1974 thru 31 March 1975.

TAB A TO APPENDIX 4 TO ANNEX E

BULK POL

<u>PRODUCT</u>	<u>DEC 73 (DFSC)</u>	<u>COST PER CUBIC METER</u>		<u>APR 75</u>	<u>% INCREASE</u>
		<u>FEB 74</u>	<u>OCT 74</u>		
AVGAS 115/145	\$57.53	\$116.23	\$148.94	\$174.37	203%
JP-4	\$33.85	\$ 82.29	\$ 99.81	\$ 99.81	194%
MOGAS	\$38.69	\$ 92.71	\$116.15	\$116.15	200%
ADO	\$31.35	\$ 94.64	\$103.77	\$110.85	254%

SELECTED PACKAGED PRODUCTS

<u>PRODUCT</u>	<u>FEB 74</u>	<u>MAR 75</u>	<u>% INCREASE</u>
OE HDO 30	\$44.71	\$76.93	72%
GO 90	\$41.40	\$87.72	119%
KEROSENE	\$16.10	\$37.36	132%
LAD II	\$40.76	\$91.30	123%
ADI	\$14.54	\$69.04	374%

TAB B TO APPENDIX 4 ANNEX E

TANKER DELIVERY OF MILITARY BULK POL TO PHNOM PENH AND KOMPONG SOM

(20 FEB 74 - 31 MAR 75)

<u>MONTH</u>	<u>AVGAS</u>	<u>JP-4</u>	<u>MOGAS</u>	<u>ADO</u>
(ALL QUANTITIES IN CUBIC METERS) *				
20-28 FEB 74	1690	899	1238	2483
MAR 74	1386	0	831	2649
APR 74	3350	2537	2891	3953
MAY 74	2830	781	2052	1687
JUN 74	1432	0	1141	2643
JUL 74	1418	993	2337	3197
AUG 74	1472	197	1944	2676
SEP 74	1997	1239	2357	3463
OCT 74	1542	765	2086	3277
NOV 74	3689	724	2179	5342
DEC 74	2785	482	2349	4539
JAN 75	921	1539	295	0
FEB 75	443	442	197	592
MAR 75	200	0	160	200

\* 1 cubic meter equals 264.2 U.S. Gallons

TAB C TO APPENDIX 4 TO ANNEX E

MILITARY DEPOT LOCATIONS

<u>LOCATION</u>	<u>FANK</u>	<u>KAF</u>	<u>MNK</u>
PREK PHNAU	X		
POCHENTONG AF		X	
SRAS CHAK (PHNOM PENH)	X		
TUK THLA (PHNOM PENH)	X		
BATTAMBANG	X	X	
SIEM REAP	X		
PURSAT	X		
KRAKOR	X		
KG CHAM	X	X	
KG CHHNANG	X	X	X
NEAK LOEUNG	X		XX *
KG SPEU	X		
KG SOM	X	X	
KAMPOT	X		
REAM		X	X
MEKONG BARGE			XX *
CHRUEY CHANG WAR			X

\* Two MNK depots at each of these locations.



TAB D TO APPENDIX 4 TO ANNEX E

AVIATION FUEL LOSSES

OCTOBER 1973 - FEBRUARY 1975

DOLLAR VALUE OF LOSSES

<u>MONTH</u>	<u>AVGAS</u>	<u>JP-4</u>	<u>TOTAL</u>
	\$	\$	\$
OCT 73	27,319	18,957	46,276
NOV 73	31,684	23,696	55,380
DEC 73	40,299	31,099	71,395
JAN 74	95,077	42,-04	137,081
FEB 74	116,470	33,475	149,945
MAR 74	124,496	47,824	172,320
APR 74	113,557	46,231	159,787
MAY 74	73,574	27,073	100,647
JUN 74	18,213	10,192	28,405
JUL 74	NO LOSS	NO LOSS	NO LOSS
AUG 74	6,100	8,879	14,979
SEP 74	NO LOSS	4,090	4,090
OCT 74	NO LOSS	6,684	6,684
NOV 74	NO LOSS	4,224	4,224
DEC 74	NO LOSS	1,496	1,496
JAN 75	NO LOSS	5,190	5,190
FEB 75	NO LOSS	NO LOSS	NO LOSS

APPENDIX 5 TO ANNEX E

TRANSPORTATION

1. GENERAL. Movement control functions of Services Branch, Ammunition and Service Division, encompassed movement of MAP-CB cargo into the GKR ports of entry from CONUS, or US bases of supply located in the Pacific area, and the movement into depots and supply bases within the GKR from ports of entry. The movement of MAP-CB cargo into GKR ports of entry was accomplished by designating a mode of delivery based on required delivery dates and then assuring that MAP-CB cargo delivery was made to the desired port of entry once cargo arrived in the theater. The MEDTC Transportation Section maintained liaison with Military Sea-Lift Command, Thailand and USARSUPTHAI to coordinate desired surface mode of transport and appropriate destination within the Khmer Republic of cargo transshipped from Thailand. The Transportation Section coordinated surface movement of cargo transshipped at Vung Tau, Republic of Vietnam, by coordinating with Military Sea-Lift Command, Saigon. Aerial movement by USAF aircraft of MAP-CB cargo into the Khmer Republic was accomplished through coordination with PATMA Thai U-Tapao RTWAB, Thailand. Internal movement within the GKR from ports of entry to the depots was a function of the FANK J-4. To accomplish this mission, the J-4 had a Joint Transportation Board which met to allocate transportation assets of each mode. The JTB consisted of members of Army, Navy, and Air Force who committed portions of their respective assets to accomplish the cargo movements. The actual movement order was then accomplished by the Director of Transportation acting for the JTB and J-4. The director of Transportation issued orders to all modes to move cargo within the guidance of the JTB and priorities established by the FANK J-3. Although the execution of transportation missions assigned to a single service improved over the reporting period, the smooth flow of passengers and cargo from one mode to another was rarely realized. Cargo and passengers would often wait excessive periods of time due to FANK's inability to coordinate the entire movement with all service commanders and staff sections. Frequently a sound tactical maneuver would become ineffective due to the untimely arrival of MNK river transportation or the non-arrival of truck or aircraft transportation. In February 1975, the concept of a Transportation Movement Control Center was proposed to the FANK. The idea to have a single point of contact for the movement of personnel and cargo was warmly received; however, it was never fully implemented.

2. HIGHWAY MOVEMENT OF CARGO. Highway transport was used to deliver ammunition via Route 5 from Thailand to Battambang. Ammunition was moved by Thai contractors (ETO) per US-Thai agreement. The shipments moved each month from ammo depots in Thailand to Battambang for resupply to the northern provinces of the GKR. After closure of Route 5 from Phnom Penh to Kompong Chhnang, it became necessary to increase the tonnage moved by this means, since Kompong Chhnang was then supplied from Battambang instead of Phnom Penh. The two most vital road links to Phnom Penh, Routes 4 and 5,

were interdicted in the Fall of 1973 and reopened only for very short periods of time. The closure of Route 5 denied FANK any highway link between its two major population centers of Phnom Penh and the rice bowl area of Battambang. This closing forced greater reliance on the Mekong River LOC for rice delivery to the capital. Ships due to call at Kompong Som Port with MAP cargo were diverted to Sattahip, Thailand, and Vung Tau, RVN, for transshipment by barge to Phnom Penh via the Mekong. Route 4 was opened by a concentrated FANK effort in January 1974, and convoys began to move immediately to relieve the equipment backed up in Kompong Som; however, it was not long before the route again closed, this time permanently. See Tab A for a breakout of tonnage transported.

3. WATER MOVEMENT OF CARGO. Waterborne cargo has traditionally been the lifeblood of Cambodia with the Mekong River the transportation life-line. This LOC continued to be of utmost importance for delivery of MAP-CB supplies and ammunition to the population center of Phnom Penh. With the move of most MAP-CB supply support from Thailand, the SCOOT (Support Cambodia Out of Thailand) tug and barge contract was negotiated by Military Sea-Lift Command Far East Yokohama, Japan, to provide for ammunition barges loaded at Vayama, Thailand to be towed to Vung Tau, RVN, thence via the Mekong river to the Port of Phnom Penh. The second water LOC for Cambodia was by ocean vessel to Kompong Som and then transshipped via Route 4 to units in that enclave. (Kompong Som, Cambodia's only deep water port, was developed during the regime of Prince Sihanouk in the late 1960's, and in the early 1970's provided a deep water port for Communist Bloc countries to discharge war materiel to the NVA forces occupying Cambodian soil fighting against the RVN all along the Cambodian/Vietnamese border.) The arrival of ocean cargo vessels and barges at Kompong Som continued at the irregular pace of two to three vessels per month. Limited ammo shipments were also made into Kompong Som by SCOOT tug and barge assets to support the ammo requirements of the maritime provinces. These shipments were limited by the ammo storage capability as well as availability of SCOOT assets. Additional internal water LOC's were developed by GKR forges operating on the Mekong and Tonle Sap rivers. MNK riverine convoys played an important, if not vital, role in the defense of enclaves by running convoys under fire up the Mekong after cities were cut off by enemy action. MNK also operated convoys as far north as the Great Lake (Tonle Sap), Siem Reap, and Kompong Chhnang; however, as the Khmer Rouge closed in during January 1975, the routes became less usable. The last Mekong River Convoy was TP 113 which arrived at Phnom Penh on 30 January 1975. See Tab A for breakout of cargo transported.

4. AIR MOVEMENT OF CARGO. The U.S. Airlift Operation in the Khmer Republic from 11 April 1973 to 17 April 1975 stands out as the largest sustained airlift operation since the Berlin Airlift. The survival of Phnom Penh and several important isolated provincial enclaves became

dependent on US Airlift to provide life-sustaining rice, ammo, POL and general cargo. USAF C-130's (including those crewed by Bird Air, a civilian contractor, and contracted DC-8's) flew 5,413 airland missions to deliver 123,631 short tons in the two-year sustained operation. The continuous Khmer airdrop support to approximately 25 different enclaves, such as Kompong Seila and Neak Luong, was the largest sustained airdrop effort in USAF history. USAF C-130's flew more than 3,000 airdrop missions to deliver 38,893 short tons of ammunition and rice, which is more than three times the tonnage delivered to Khe Sanh, Vietnam in 1968. The airdrops were highly successful, using the AWADS high-altitude (12,000 feet), high-velocity drop system in a combat environment. Approximately 98 percent of total bundles dropped were reported recoverable, even though some of the drop zones had less than 500 meter radii of security. Neither USAF nor KAF lost any aircraft to enemy fire during airdrop operations. To reduce US Military presence in the Khmer Republic, USAF contracted with Bird Air for civilian aircrews after 7 October 1974. All flights into the Khmer Republic, other than a small number of USAF-crewed Administrative Support flights, were crewed by civilian aircrews. As airlift requirements increased, the contract was expanded to 15 aircrews. The best results were recorded on 17 March 1975, when 34 missions were flown (26 airland and 8 airdrops), delivering 654.1 short tons to Phnom Penh and Neak Luong. During February 1975, the MAP-CB airlift was supplemented with three MAC-contracted DC-8's to provide ammo airlift from U Tapao to Pochentong. World Airways and Airlift International flew 111 missions from 15 to 26 February 1975, when 11 missions delivered 523.5 short tons. At the completion of MAP-CB augmentation on 27 February 1975, the Airlift International and World Airways DC-8 operations moved to Saigon and were joined by Trans International (TIA), Flying Tiger, and Seaboard World which began to provide airlift of USAID rice and kerosene to Pochentong. The DC-8's delivered 27,480 short tons of rice and 873 short tons of kerosene to Pochentong in 617 missions. A TIA DC-8 flew 58 missions to airlift 2,763 short tons of ammo from U Tapao from 4 to 21 March 1975 as trade-off for C-130 "bladder birds" transporting USAID fuel. On 18 March 1975, a record total, 1,133.9 short tons of rice, ammo, and kerosene, was delivered to Pochentong. The largest single day for rice delivery was 1085.6 short tons on 31 March 1975. See Tab A for a break out of tonnage transported. This huge airlift was conducted under difficult and hostile conditions. From 1 January 1975 until 17 April 1975, over 2,500 105mm howitzer shells and 107mm rockets impacted on or near Pochentong airfield. Impact patterns were monitored continuously and every conceivable step was taken to minimize the possibility of damage. These steps included changing operational patterns, movement of offload activities to areas of least impact, and, when prudence dictated, suspension of operation for variable periods of time until favorable changes in the impact pattern could be discerned. These steps, plus a large measure of good fortune resulted in the completion of the airlift with no loss of aircraft or American lives. There were eight instances of aircraft receiving minor to moderate shrapnel damage, and nine members of the Khmer military and civilian offload crews were killed and some 40 were wounded. The performance of all US personnel in a most demanding and hostile environment at Phnom Penh and under a relatively primitive operating condition was outstanding. There were numerous instances of individual performance in the sustained Khmer Airlift which reflect impressive dedication and heroism.

THIRD COUNTRY NATIONALS (TCN)

1. GENERAL. Since the ammunition program to support the GKR was such a dominant part of MAP-CB, extraordinary measures were required to manage, control and conserve the assets. Due to a Congressional limitation on the number of US personnel that could be in Cambodia at any one time, it was impossible for the Ammunition Branch to perform its necessary management functions without additional personnel support to provide required information on the storage, receipt, issue, and maintenance of stocks in the main Phnom Penh depots and at the various enclaves. In addition, the FANK ammunition management structure was relatively unsophisticated; therefore, training in US ammunition supply procedures was required.

2. HIRING AND ASSIGNMENT.

a. To solve these problems, four TCN's were hired directly by the US and with the concurrence of the Country Team, an additional sixteen were hired by the FANK. The contract agency that maintained overall supervision of TCN's was the Vinnell Corporation, Alhambra, California with offices in Phnom Penh and Saigon. The majority of the TCN's hired were Koreans who had extensive experience in US procedures for storage, stock record accounting, and maintenance of ammunition. They were assigned to the major storage sites, to regional depots, and to each of the four divisions.

b. Throughout the period of their service in Cambodia, the ammunition TCN's provided an invaluable service and source of information without which the program could not have been managed. Their loyalty, dedication and honesty was truly inspiring to those personnel of MEDTC who were fortunate enough to be associated with them.

PROGRAMMING MANAGEMENT

1. ORGANIZATIONAL RELATIONSHIPS.

During the period February through July 1974, MEDTC programming management was performed in Plans and Programs Division, a functionally-oriented staff element. In August 1974, MEDTC was reorganized along component service lines (Army, Navy, Air Force Divisions) to facilitate more effective interface with the component services of the Khmer Armed Forces. Because of the obvious importance of ammunition and related services, a separate Ammunition Division was established. Each of the divisions had its own programmer. To provide a continuous perspective of MAP-CB overall, the position of Chief Programmer was established in the office of the Special Assistant for Coordination and Special Actions (SACSA).

It was recognized that Congressionally imposed headspace limitations precluded programmers from being engaged full time in programming activities. Moreover, analyses and special studies that the programming function could accomplish for management were not available with such a limited, decentralized, non-computer supported staff.

An ad hoc study group (October 1974-January 1975) concluded that a functionally-oriented programming unit, based in Thailand with computer support, would best serve the programming needs of MEDTC. Two prerequisites to such a support element were: dedicated secure communications with the MEDTC staff in Phnom Penh and the presence of one programmer at the forward location. This Thailand-based programming facility was not tested. Probably the most effective organization would have been functionally-oriented and based in Phnom Penh. Headspace limitations, however, precluded such an arrangement.

2. AUDIT/INSPECTION.

Since the Chief Programmer's role in MEDTC was concerned with overall management of programming, it is natural that the function would be concerned with DOD and GAO audits, and State Department (IGA) inspections of MAP-CB management. Overall, those "external" reviews were objective and they presented constructive and useful evaluations, which were surprisingly similar assessments of the environment and management of MAP-CB.

3. PROGRAMMING.

Two major funding restrictions which frustrated MAP-CB program management during the period February 1974 - April 1975 were continuing resolution authority (CRA) and Section 506 drawdown authority under the Foreign Assistance Act of 1961, as amended in 1974.

a. In contrast to a regular appropriation by Congress, which provides definite funding for a program over time, CRA for MAP-CB required detailed justification for funds on a case-by-case basis at quarterly intervals.

[REDACTED] [REDACTED]

For ammunition, the frequency was at 30-day intervals. A subtle limitation created by such frequent justification was incremental control of funding that had already been approved. Often, the increments themselves contained less than the amount requested. For example, MEDTC requested \$49.4 million in constrained financing for the third quarter, FY 75. MEDTC received only \$43.1 million, or a shortfall of \$6.3 million. Still another restriction of CRA funding is that it could not be used as an instrument of financing for many new investment programs.

b. Section 506 drawdown authority hampers program management, since it can be used only for goods and services which are available within military department resources or on existing contracts. For example, that authority cannot be used for new procurement. Neither can funds under new obligation authority (NOA) be freed by using Section 506 funds to pay for eligible goods and services already delivered. Included in the shortfall of \$6.3 million in MEDTC's third quarter funding request was \$2.9 million for POL which was not eligible for Section 506 funding.

c. Aside from the restrictions of CRA and Section 506 drawdown authority, the third and major factor which frustrated MAP-CB program management was an inadequate level of funding.

In February 1974, MEDTC had formulated its FY 75 program requirements at a level of \$521.6M (Appendix 1). At that time CINCPAC requested reduction of the program to a guideline level of \$362.5M. The adjustment deferred \$159.2M into shortfall which required careful evaluation of its impact on MAP-CB.

Without question the guideline level of \$362.5M was insufficient to satisfy what were considered optimum requirements for FY75 MAP-CB. For example, it relegated MEDTC to a level of only 78% (\$299.8M) of its ammunition requirements. The required \$380.2M level of ammunition was fully justified by a continuing high level of combat intensity, greater weapon densities, and escalating price increases. A shortfall in the Army program of \$28.6M threw into shortfall urgently needed logistical units augmenting the Khmer Army force structure. More importantly, it further delayed the replacement of rapidly deteriorating equipment.

The Air Force shortfall of \$19.5M delayed acquisition of the first segment of utility aircraft to replace the O-1D. Other impact was delay in the acquisition of attrition aircraft; impairment of the ability to acquire the third UH-1H helicopter squadron; inability to develop the second UH-1H and C-123 squadrons to the authorized level; and postponement of airfield expansion and related construction projects.

[REDACTED] [REDACTED]

The Navy shortfall of \$30.0M continued the delay in acquisition of the 50-craft, Fourth Riverine Task Force (RTF) consisting of Monitors, ATCs, ASPBs, MSPs, CSBs, LCM-8s, LCM-6s and PRRs. This RTF was needed so that the Navy could reassert its influence on the Tonle Sap River and into the Great Lake. In addition, the shortfall caused considerable stress on the attrition replacement of Naval craft.

d. On 19 December 1974, almost half way through FY75, Congress passed the Foreign Aid Authorization Act. The law imposed a MAP-CB ceiling of \$275 million, consisting of \$200 million in new obligation authority (NOA) and \$75 million in Section 506 drawdown authority. Several critical observations are relevant as a result of the Congressional action:

(1) For the first time, the cost of packing, crating, handling, and transportation (PCH&T) of \$51 million was charged to the MAP-CB ceiling. Heretofore, PCH&T was charged to worldwide MAP funds.

(2) As Appendix 1 indicates, the reduction from the previous guideline level of \$362.7 million to \$275 million was substantial. However, a more realistic basis for comparison is to factor into the equation the new charge of \$51 million PCH&T. Thus, Congressional action effectively reduced the program from \$362.7 million to \$224 million, a reduction of \$138.7 million or 38%.

(3) As of the end of the first half of FY75, the funded program for ammunition, Army, Navy, Air Force, and Training was \$142.5 million or 64% of the effective ceiling of \$224.0 million. With only 36%, or \$81.5 million, remaining to fund the last half of FY75 (during which Dry Season combat activity would surely increase for the FANK), the total inadequacy of the funding level in terms of attaining minimum US objectives was clearly apparent.

(4) Up to the first week of February 1975, MEDTC programming management was a continual challenge because of escalating and rapidly shifting combat needs, uncertain CRA funding, and restrictive Section 506 drawdown funding. Subsequently, there was no doubt that there were to be a number of costs, heretofore not charged to MAP-CB, which would now be levied against the authorized ceiling of \$275 million. Those costs, over which Chief of MEDTC could exercise only minimal control, were: PCH&T; MEDTC administrative costs (including military pay and allowances of assigned personnel); redistributable MAP material; overseas excess defense articles; and USAF aircraft maintenance (including the military pay and allowances of USAF maintenance personnel). Because of the necessity for progressively more premium airlift during the period February-April 1975 (caused by the closing of the Lower Mekong), those mandatory charges against the ceiling grew from \$72.8 million to \$77.1 million. A parallel development was the pressing need to finance critical new requirements which were generated by the growing urgency of the combat environment.

[REDACTED] [REDACTED]



[REDACTED] [REDACTED]

(5) On 7 February 1975, all available funds under the \$275 million ceiling were exhausted. Since requirements were still escalating, programming shifted to day-to-day, intensified management from that date onward. This effort required constant assessment of vital requirements in relationship to essential but less vital requirements. Using assessment results, the most critical needs were funded by reprogramming from the lower priority program lines. Within days it was necessary to cancel long leadtime investment programs in order to finance current operations. Typical examples of these requirements were:

Additional Airlift by Commercial Carriers	\$1.2M
Aerial Delivery Equipment To Resupply Enclaves by Airdrop in lieu of MNK surface mode.	\$2.3M
Airlanding of ammunition and POL through 17 April 1975.	\$4.4M

(6) After the evacuation of Phnom Penh on 12 April, programming management emphasis shifted to validating the claims, many of which were belated, against MAP-CB funds. This effort required considerable "second guessing" and use of funds which the military departments (ILC, AFLC, and NAVILCO) reported as available. The cancellation of requisitions, suspension of materiel in the pipelines, and the subsequent reversal of the materiel flow to depots and other cosignors eventually provided sufficient funds to finance the additional claims against MAP-CB. This pattern is expected to continue until the eventual close-out of MAP-CB.

[REDACTED] [REDACTED]

Appendix 2 to Annex F

MAP-CB  
AUDITS/INSPECTIONS  
FEBRUARY 1974-APRIL 1975

Audit Report #492 (30 April 1974), Report on the Review of Controls Over Aviation Gasoline Provided to the Khmer Republic Air Force, Deputy Assistant Secretary of Defense (Audit).

Draft Audit Report (November 1974), Report on Review of the Security Assistance Program for Cambodia, Deputy Assistant Secretary of Defense (Audit)

Inspection Report (31 December 1974), Review of Supply Management of Ammunition Provided to Cambodia Under the Military Assistance Program, The Inspector General of Foreign Assistance (IGA), Department of State

Review in Process (October 1974 - January 1975), Review of POL Operations and Accounting, General Accounting Office (GAO).

Annex H

GLOSSARY OF TERMS

ABC Report	A cumulative listing of receipts of specified major items.
ACPER	Assistant Chief of Staff Personnel (FANK).
ADE	Aerial delivery equipment.
AGE	Aerospace Ground Equipment.
ALCPT	American Language Course Placement Test.
ALO	Air Liaison Officer.
AMEMB	American Embassy.
AO	Area of Operations.
AOCC	Air Operations Control Center.
APC	Armored Personnel Carrier.
APG	Airplane General.
APS	Aerial Port Squadron.
ARG/MAU	Amphibious Ready Group/Marine Aviation Unit.
ARVN	South Vietnamese Army.
ASR	Authorized Supply Rate.
AVNAV	Avionics Navigation Equipment.
AWADS	Adverse Weather Aerial Delivery System.
BDA	Bomb Damage Assessment.
BFM	"Battalion Fusiler Marine" (Naval Infantry Battalion, Khmer Navy).
CB	Cambodia.
CBU	Cluster Bomb Unit.
CCB	Command and Communications Boat.

OCT	Combat Control Team or Combat Crew Training.
CDS	Containerized Delivery System.
C-E	Communications-Electronics.
CGSC	Command and General Staff College.
CHMEDTC	Chief, Military Equipment Delivery Team, Cambodia.
CLII	"Centre Instruction Infanterie" (National Training Center).
CINCFANK	Commander-in-Chief, FANK.
CINCPAC	Commander-in-Chief, Pacific.
CINCPACINST	Commander-in-Chief, Pacific Instruction-
CIP	Commodity Import Program.
CNO	Chief of Naval Operations.
COMUSMACTHAI	Commander, United States Military Assistance Command, Thailand.
COMUSMACV	Commander, United States Military Assistance Command, Vietnam.
CONUS	Continental United States.
CP	Co-pilot.
CRA	Continuing Resolution Authority.
DAO	Defense Attache Office.
DASC	Direct Air Support Center.
DATT	Defense Attache.
DCSS	Director Central Health Service (FANK).
DCT	Director of Communications (FANK).
DGI	Director General of Instruction (FANK).
DGL	Director General of Logistics (FANK).
DIRCON	Director of Construction (FANK).
DIRENGIE	Director of Engineers (FANK).

DIRINTENDENCE	Director of Intendence (FANK Quartermaster).
DIRMAT	Director of Material (FANK).
DIRSANTIS	Director of Health (FANK).
DLI	Defense Language Institute.
DN	"Defense Nationale", Ministry of National Defense.
DOD	Department of Defense.
DODIC	Department of Defense Identification Code.
DPSC	Defense Personnel Support Center.
DRV	Democratic Republic of Vietnam (North Vietnam).
DS	Direct Support.
DSAA	Defense Security Assistance Agency.
ESU	Direct Support Unit.
DTL	Directorate of Training and Logistics (USMACVTHAI).
DX	Direct Exchange.
ECL	English Language Comprehension.
EIUI	End Item Utilization Inspection.
EMG	"Etat Major Generale" (Khmer General Staff).
FAC	Forward Air Controller.
FAG	Forward Air Guide.
FANK	"Forces Armees Nationales Khmeres" (Khmer Armed Forces, including Army, Navy, Air Force. The term is often used when referring only to the Army).
FAO	Foreign Assistance Office.
FCF	Functional Check Flight.
FDC	Fire Direction Center.
FEC	Federal Electric Corporation.
FIN SVC	Finance Service.
FL	Flight Lead.

FMS	Field Maintenance Squadron.
FP	First Pilot.
FSOC	Fire Support Coordination Center.
FSN	Federal Stock Number.
FY	Fiscal Year.
GAO	General Accounting Office.
GKR	Government of the Khmer Republic.
GS	General Support.
HF	High Frequency.
IAW	In accordance with.
ICC	International Control Commission.
ID	Identification.
IMF	International Monetary Fund.
IMLE	Military Institute of Foreign Languages.
INTENDANT	Quartermaster.
IPIC	Instrument Pilot Instructor Course.
IRAN	Inspect, Repair as needed.
ITO	Invitational Travel Orders.
JCS	Joint Chiefs of Staff.
JLO	Joint Liaison Officer (MEDTC Rear, Thailand).
JMP	Joint Manpower Program.
JSOP	Joint Strategic Objectives Plan.
JTD	Joint Table of Distribution.
KAF	Khmer Air Force.
KC	Khmer Communists.
KI	Khmer Insurgent

KRASS	Khmer Republic Automated Supply System.
KSF	Khmer Special Forces.
LCI	Infantry Landing Ship.
LCM	Landing Craft Medium.
LMAT	Logistics Management Assistance Team.
INO	Liaison Officer.
LOC	Line of Communication.
LOCC	Logistics Operations Control Center.
LOG	Logistics.
LSIL	Infantry Landing Ship.
MACTHAI	Military Assistance Command, Thailand.
MACTLN	Training and Liaison Section (USMACTHAI).
MACV	Military Assistance Command, Vietnam.
MAE	MAP Administrative Executive Funds.
MAP	Military Assistance Program.
MAP-CB	Military Assistance Program, Cambodia.
MAPEL	Military Assistance Program Element.
MAPEAS	Military Assistance Program Equipment Authorization System.
MAPEX	Short Title for Transferable assets excess to PACOM needs.
MASL	Military Articles and Services List.
MASM	Military Assistance and Sales Manual.
MC	Maintenance Control.
MCM	Central Material Depot (FANK).
MEDT	Military Equipment Delivery Team.
MEDTC	Military Equipment Delivery Team, Cambodia.
MILSTRIP	Military Standard Requisitioning and Issuance Procedure.

MIMEX	Short Title for transferable property excess to military department needs.
MMS	Munitions Maintenance Squadron.
MNK	"Marine Nationale Khmère" (Khmer Navy).
MOS	Military Occupational Specialty.
MR	Military Region.
MSCFE	Military Sealift Command, Far East.
MSM/MSR	Minesweeper, River
M/T/DAY	Metric Ton Per Day.
MIT	Mobile Training Team.
NAVILCO	Naval International Logistics Center.
NDI	Non-destructive Inspection.
NEMVAC	Emergency Evacuation Plan.
NKP	Nakhon Phanom (Town located in NE Thailand. HQ USSAG and 7th Air Force at airbase at the same location).
NN	MASL Code which indicates DSAA approval required for MAP Programming.
NOA	New Obligation Authority.
NORS	Not Operationally ready for supply.
NOTE DE SERVICE	Administrative notice/general order within FANK.
NVA	North Vietnamese Army.
OICC	Officer in Charge Construction.
OJT	On-the-job Training.
O&M	Operations and Maintenance.
OMS	Organizational Maintenance Squadron.
OR	Operationally Ready.
OSP	Offshore Procurement.
PACOM	Pacific Command.



PARA	Paratroop/Parachute.
PATMA	Pacific Command Transportation Movement Agency.
PBR	Patrol Boat River
PC	Patrol Craft.
PCA	Central Pharmaceutical Depot (FANK).
PCF	Patrol Craft Fast.
PCHST	Packing, Crating, Handling, and Transportation.
PDO	Property Disposal Officer.
PIT	Pilot Instructor Training.
PL 480	Public Law 480
POI	Program of Instruction.
POL	Petroleum, Oil, Lubricants.
POL MIL	Political Military (Sub Element of US Mission).
POL WAR	Political Warfare.
POM	Program Objectives Memorandum.
PPBS	Planning, Programming and Budget System.
PRG	Provisional Revolutionary Government (Viet Cong).
PROAG	Project Agreement.
QC	Quality Control.
QG/AA	Administrative Headquarters (FANK).
RCN	Record Control Number.
RDD	Required Delivery Date.
R&D	Research and Development.
RIEL	The Khmer Monetary Unit.
RMS	Special Military Region.
RN	National Route.

RPG	Rocket Propelled Grenade.
R&R	Repair and Return.
RSR	Required Supply Rate.
RTA	Royal Thai Army.
RTAF	Royal Thai Air Force.
RTAFB	Royal Thai Air Force Base.
RIG	Royal Thai Government.
RINAB	Royal Thai Naval Air Base.
RVNAF	Republic of Vietnam Armed Forces.
RVN	Republic of Vietnam.
SA/POM	Security Assistance/Program Objectives Memorandum.
SCHQ (F)	Supreme Command Headquarters (FWD) (Thai)
SCOOT	Support Cambodia Out of Thailand.
SCOOT/T	Support Cambodia Out of Thailand/Transshipment.
SECDEF	Secretary of Defense.
SITREPS	Situation Reports.
SKE	Station Keeping Equipment.
SONEXIM	"Société Nationale Export/Import" (Khmer Export/Import Company)
SOWG	Special Operations Wing.
SSMR	Single Senior Military Representative.
S/T	Short Ton
STOL	Short Take Off and Landing.
SVN	South Vietnam.
TACAN	Tactical Air Navigation.
TAIP	Tactical Air Improvement Plan.
TCN	Third Country National.

TCO	Test Control Officer
TED	Table of Organization and Equipment.
TLA	Travel and Living Allowance (FRANK Students).
TOSE	Table of Organization and Equipment.
UNGA	United Nations General Assembly.
UNOFFICIAL AMERICANS	US Citizens who were not employed by the US Mission (Cambodia).
USAAAT	US Army Ammunition Activity Thailand.
USAID	US Agency for International Development.
USARPACINTA	US Army Pacific Intelligence Agency.
USARSUPHAI	US Army Support, Thailand.
USDA	US Department of Agriculture.
USG	US Government.
USIA	US Information Agency.
USMACTHAI	US Military Assistance Command, Thailand.
USMACTHAI SPT GP	US Military Assistance Command, Thailand, Support Group.
USN	US Navy
UPT	Undergraduate Pilot Training.
USSAG	US Security Assistance Group.
VC	Viet Cong
VNAF	South Vietnamese Air Force.
VNN	South Vietnamese Navy.
WESTPAC	Western Pacific.
WIA	Wounded in Action
ZSM	"Zone Speciale Mekong" (Mekong Special Zone).