

AD-A264 866



1

Oil and Hydrocarbon Spill Bioremediation
Product and Application
Technologies

DTIC
ELECTE
MAY 24 1993
S C D

A PROJECT
BY
MARK RICHARD DEIBERT

Submitted to the Office of Graduate Studies at
Texas A&M University
in partial fulfillment of the requirements for the degree of
MASTERS OF ENGINEERING

May 1993

Major Subject: Civil Engineering

DISTRIBUTION STATEMENT A
Approved for public release
Distribution Unlimited

93 5

93-11419



Acknowledgements

I wish to extend my gratitude and sincere appreciation to the following persons:

Dr. W. M. Stallard for his support in getting me started at Texas A&M and being a committee member;

Dr. K.C. Donnelly for providing me the fundamentals of biodegradation and being a committee member;

Dr. R.W. Hann, Jr. for allowing me to pursue the topic and for being the chairman of the committee;

The U.S. Navy for allowing me the opportunity to attend graduate school at Texas A&M University;

My mother and father, for without their never ending support and encouragement, I would not be where I am today;

And most of all, my wife and son, whose constant love and joy bring me my greatest inspirations.

Accession For	
NTIS CRA&I	<input checked="" type="checkbox"/>
DTIC TAB	<input type="checkbox"/>
Unannounced	<input type="checkbox"/>
Justification	
By <i>Per Form 50</i>	
Distribution /	
Availability Codes	
Dist	Avail and/or Special
<i>A-1</i>	

TABLE OF CONTENTS

Acknowledgements.....	i
Table of Contents.....	ii
List of Tables.....	iv
List of Figures.....	v
Abstract.....	1
Section I - Biodegradation	
1.1 Biodegradation basics.....	2
1.2 Microorganisms.....	2
1.3 Consortium.....	5
1.4 Oxygen.....	6
1.5 Nutrients.....	7
1.6 Temperature.....	8
1.7 Moisture.....	9
1.8 pH.....	9
1.9 Organic matter.....	10
1.10 Oil surface and concentration.....	10
1.11 Salinity.....	11
1.12 Summary.....	11
Section II - Source, Composition, and Fate of Petroleum Products	
2.1 Sources.....	13
2.2 Hydrocarbon classification.....	13
2.3 Crude classification.....	14
2.4 Composition of petroleum products.....	15
2.4.1 Crude oil.....	15
2.4.2 Kerosene.....	15
2.4.3 Fuel oil/ diesel #2.....	16
2.4.4 Gasoline.....	16
2.4.5 Jet fuel.....	16
2.5 Fate of oil and biodegradation effects.....	18
2.5.1 Spreading.....	18
2.5.2 Evaporation.....	18
2.5.3 Dispersion.....	19
2.5.4 Emulsification.....	19
2.5.5 Density.....	20
2.5.6 Solubility.....	20
2.5.7 Sorption.....	21
2.5.8 Chemical structure.....	22
2.6 Summary.....	23

Section III - Bioproduct and Application Technology	
3.1 Introduction.....	25
3.2 Bioproduct technology.....	26
3.3 Bioproduct classification.....	27
3.4 Bioproduct review.....	28
3.5 Application technology.....	33
3.5.1 Delivery platforms.....	34
3.5.1.1 Aircraft.....	35
3.5.1.2 Boats.....	37
3.5.1.3 Land vehicles.....	39
3.5.2 Equipment.....	44
3.6 Summary.....	52
Section IV - Problems Associated with Bioremediation Technology	
4.1 Introduction.....	57
4.2 General problems.....	57
4.3 Specific problems.....	59
Conclusions.....	69
References.....	70
Appendices.....	73
Vita.....	104

LIST OF TABLES

<u>Table</u>	<u>Title</u>	<u>Page</u>
1	Major genera of oil-degrading bacteria and fungi.	3
2	Percent composition of 5 common crudes.	15
3	Delivery platform application matrix.	54

LIST OF FIGURES

<u>FIGURE</u>	<u>TITLE</u>	<u>PAGE</u>
1	Common distilled petroleum products.	17
2	Typical landing craft.	40
3	Terra-gator tank vehicle.	41
4	GST amphibious vehicle.	41
5	Air cushioned vehicle (ACV).	43
6	All terrain vehicle (ATV).	45
7	Eductor type nozzles.	46
8	CH-53 Sea Dragon and mine sled.	49
9	Back pack spray unit.	51
10	Blower unit.	51

Abstract

Oil and Hydrocarbon Spill Bioremediation Product and Application Technology

May 1993

Mark Richard Deibert, B.S.C.E., Oklahoma State University

Chair of Advisory Committee: Dr. Roy W. Hann, Jr.

This manuscript was prepared for use by U.S. Navy personnel to increase the awareness of the use of microbes and related technology associated in the remediation of hydrocarbon spills. Petroleum products are vastly used in every day naval operations, and spills will be inevitable. In researching the information and obtaining data from U.S. Navy commands, it quickly became obvious that the operational Navy knew little of this information and was not using bioremediation as a possible remedial technology. It is the intent of this manuscript to be used as a guide to assist and educate naval planners in understanding the role of bioremediation for site cleanup. As defense dollars shrink and the technology grows, bioremediation will become an attractive, economical means for the Navy's environmental problems. Thus, knowledge of the technology is important so as to not be misled by marketing experts with widely exaggerated claims of performance. The technology works well in most cases, yet problems can exist that must be questioned.

The manuscript is divided into four sections. Section I will review biodegradation basics and factors affecting the degradation process. Section II will discuss the composition of oil and related petroleum products and their physical states in water and soil environments. Section III examines the types of commercially available microbial products and the technology that can be used to dispense them in open seas, harbors, marshes, and shore facilities should a spill occur. Section IV will address the possible problems and associated drawbacks of bioremediation and will provide a list of questions to ensure the product and technology will perform as claimed.

Keywords: biodegradation, bioproducts, delivery platforms, application equipment, technical problems.

Section I

Biodegradation

1.1 Biodegradation basics

To understand bioremediation processes, it is necessary to have a basic knowledge of the mechanisms and factors that control biodegradation. Biodegradation refers to the natural process whereby bacteria and other microorganisms alter and breakdown organic molecules into other substances. It could be one reaction or a series of reactions that may not be totally complete. Mineralization refers to the complete breakdown of organic compounds, such as petroleum hydrocarbons, to carbon dioxide and/or methane and water. Bioremediation, then, is the act of adding materials to spill sites to cause an acceleration of the natural biodegradation process. The materials added, whether microbes or nutrients, may or may not produce complete mineralization. Factors affecting this process will be discussed further in this section.

1.2 Microorganisms

Biodegradation works due to microorganisms utilizing hydrocarbons as a food source. Hydrocarbons are a rich source of carbon and energy that microbes need for growth. Before the carbon is available for use, larger hydrocarbon molecules must be broken down into simpler molecules suitable for use by other microbes. More than 70 microbial genera are known to contain organisms that can degrade hydrocarbon molecules. Hydrocarbons released in the environment are biodegraded primarily by bacteria and fungi, the most common listed in Table 1. These microbes are ubiquitous in soil, fresh water, and sea water environments.

Of the many bacteria found to degrade hydrocarbons, the most important found in marine and soil environments are Achromobacter, Acinetobacter, Alcaligenes, Arthrobacter, Bacillus, Flavobacterium, Nocardia, and Pseudomonas (Leahy and Colwell, 1990). Among the fungi listed, Aureobasidium, Candida,

Table 1—Major Genera of Oil-Degrading Bacteria and Fungi

<i>Bacteria</i>	<i>Fungi</i>
Achromobacter	Allescheria
Acinetobacter	Aspergillus
Actinomyces	Aureobasidium
Aeromonas	Botrytis
Alcaligenes	Candida
Arthrobacter	Cephalosporium
Bacillus	Cladosporium
Beneckea	Cunninghamella
Brevibacterium	Debaromyces
Coryneforms	Fusarium
Erwinia	Gonytrichum
Flavobacterium	Hansenula
Klebsiella	Helminthosporium
Lactobacillus	Mucor
Leucothrix	Oidiodendrum
Moraxella	Paecilomyces
Nocardia	Phialophora
Peptococcus	Penicillium
Pseudomonas	Rhodospiridium
Sarcina	Rhodotorula
Spherotilus	Saccharomyces
Spirillum	Saccharomycopsis
Streptomyces	Scopulariopsis
Vibrio	Sporobolomyces
Xanthomyces	Torulopsis
	Trichoderma
	Trichosporon

SOURCE: G.D. Floodgate, "The Fate of Petroleum in Marine Ecosystems," *Petroleum Microbiology*, R.M. Atlas (ed.) (New York, NY: Macmillan Publishing Co., 1984), p. 373.

Table 1. Major genera of oil degrading bacteria and fungi (U.S. Congress OTA, 1991).

Rhodotorula, and Sporobolomyces are common in marine environments and Trichoderma and Mortierella are most common in soil environments (Leahy and Colwell, 1990). In marine environments, bacteria are considered to be the predominant hydrocarbon organism. Both bacteria and fungi contribute to hydrocarbon degradation in soils, with percent contributions ranging from 50-50 to 80-20 in favor of bacteria. Even less is known about the comparative roles of bacteria, fungi, and yeasts in freshwater, as are the roles of protozoa and algae in overall degradation rates.

The microorganisms which use hydrocarbons as a food source can readily be found in vast quantities near places subjected to oil pollution, such as natural oil seeps, shipping lanes, harbors, oil fields, fuel terminals, and similar facilities. Relatively few hydrocarbon utilizers live in virgin soil or in the vast open sea. Few to none reside in petroleum as it emerges from the deep underground, as shown by the vast amount of oil that still remains underground even after millions of years.

The population of microorganisms will vary from sample to sample, depending on the location at which it was taken. Oil polluted harbors can contain $1E10^3$ to $1E10^6$ microbes/ml. Bottom ooze from Gulf Coast and California harbors range from $1E10^2$ to $1E10^9$ microbes/ml, while clean beach sand and open sea water contain none (NTIS, 1973). In terms of percentages, water not polluted by hydrocarbons typically have one percent of the population made up of hydrocarbon degrading bacteria, whereas in polluted areas they can constitute ten percent or more of the total microbial population (Green, 1990). Thus, cleanup of long standing military facilities such as fuel depots and harbors may be easier than that of an isolated accident using bioremediation technology due to an increase of hydrocarbon utilizing microorganisms.

1.3 Consortium of Microorganisms

A consortium may be defined as a mixture of different mutualistic hydrocarbon utilizing microorganism. Hydrocarbons range in size from single to many carbon molecules. The microorganisms produce enzymes (groups of proteins that mediate or promote the transformation of the hydrocarbon into a simpler compound) that attack the hydrocarbon molecule.

Some microorganisms can produce enzymes which are capable of attacking almost any size or type of hydrocarbon; others can only produce enzymes that attack and breakdown one specific type or size molecule. Once the hydrocarbon is broken, other enzymes may be required to further break the remaining hydrocarbon. Lack of a specific enzyme to attack the remaining molecule further may provide a barrier to the complete degradation and stop the process, until one is introduced to the system. This complex series of steps by which degradation occurs is called a metabolic pathway. No single species of microorganism is capable of degrading the many different hydrocarbon components in oil products, thus many different enzymes and metabolic pathways are required to degrade the significant number of compounds contained in petroleum and related products.

When a petroleum spill occurs, certain microorganisms in the system will exhibit rapid growth due to the vast availability of easily degradable hydrocarbons. These fast growing species may hinder other species by depleting oxygen or nutrients in the system. When those easily degradable hydrocarbons are depleted, the microorganisms may lack the enzyme necessary to degrade the other hydrocarbons available, and die off. Other microorganisms capable of utilizing the remaining hydrocarbons will then exhibit growth and flourish in the system. Thus, the cycle continues, as species flourish and recede as the hydrocarbons they excel at degrading become available, then are depleted.

Microorganisms that readily degrade the hydrocarbons found in petroleum products can usually be found near the surfaces of

soil and water. The main reason for this is the availability of oxygen, moisture, and the food source (the hydrocarbon) near the surface. Although some microbes are anaerobic (not growing in the presence of molecular oxygen), the vast majority of microbes that degrade hydrocarbons are aerobic (those that utilize molecular oxygen). The main factors that contribute to the biodegradation of hydrocarbons will be discussed in the sections below.

1.4 Oxygen

Since most hydrocarbon degrading microbes are aerobic, the supply of oxygen to the process is one of the more important requirements to ensure degradation. Dissolved molecular oxygen is required for respiration of the microbe and is used throughout the subsequent degradation pathway. Requirements for oxygen uptake are significant. It usually takes 3 to 4 ml of dissolved oxygen to oxidize 1 ml of hydrocarbons to carbon dioxide and water (U.S. Congress OTA, 1991). This relatively high demand is due to the high concentration of hydrogen and carbon in the oil, but very low concentrations of oxygen. Surface waters, such as oceans, harbors, and lakes, essentially have an infinite supply of oxygen due to the air/water interface and the wind and wave action. But, oxygen becomes the rate limiting effect as depth increases. At sufficient depths and in deep water sediments, degradation of the hydrocarbons can turn anaerobic when the oxygen supply is depleted. Thus, oil that is dispersed and sinks to the deep oceans and is covered by sediments will take much longer to degrade.

Oxygen replenishment can be hindered by large, thick pools of oil on water surfaces due to the blanketing of the air/water interface. This problem is most likely to occur in marshes, harbors, and inlets that rely on the flushing process provided by tidal movements. Mechanical removal is required to increase the air interface boundary necessary for oxygen replenishment.

For soil environments, the availability of oxygen is dependent on the type of soil, amount of moisture, and the rate

of microbial degradation that has occurred. Oxygen is plentiful on beach surfaces and subsurfaces where wave and tidal mechanisms contribute to reaeration and replenishment. Oxygen content will be high also near jetties, pier structures, and retaining walls subject to crashing waves. Oxygen will be limited in fine grain soils, beach fronts with little or no tidal movements, and as soil depths increase. Oxygen has been shown to be the rate limiting step of degradation of hydrocarbons in deep soils and groundwater. To alleviate these problems, the soil can be mechanically tilled to provide aeration, or, for deeper soils and groundwater, oxygen can be supplied by pumping it into a series of buried perforated pipes, by soil venting, air sparging, injection of hydrogen peroxide, and by aerating the water to provide the necessary amounts of oxygen.

1.5 Nutrients

The types and quantities of nutrients present in the system play a much more important role in limiting the rate of hydrocarbon degradation. Many studies have shown that an inadequate supply of nutrients may result in a slower rate of degradation for hydrocarbons (Roberts, 1992). The capacity of the microorganism to grow in a given system depends on the organisms ability to utilize any available nutrient. Aerobic microorganisms utilize various types of nutrients including nitrogen, phosphorus, and trace amounts of potassium, calcium, sulfur, magnesium, iron, and manganese. Nitrogen and phosphorus are vital nutrients especially since oil contains very little of either (Cunningham, 1990). The lack of either nutrient will retard natural degradation rates. Seawater is often deficient in these nutrients because non-oil degrading microorganisms consume them as well as the oil consuming species. Also, phosphorus precipitates as calcium phosphate in the presence of seawater (U.S. Congress OTA, 1991). Concentrations of nitrogen compounds in seawater range from .1 to 1 mg/l , and phosphorus ranges from 0 to .07 mg/l, depending on seasonal temperatures

(Cunningham, 1990).

To compensate for the lack of nutrients, fertilizers have been applied. Amending the soil in this manner improves the nutritional status of microorganisms and encourages growth. The amount required to degrade a certain volume of oil has not yet been thoroughly understood, though the subject is being researched (Leahy and Colwell, 1990). The different types will be discussed in Section III.

1.6 Temperature

The microorganisms which degrade hydrocarbons are most active in specified temperature ranges that govern the production of enzymes. The three classes and their optimum temperature ranges are psychrophiles (below 20C), mesophiles (15C-45C), and thermophiles (above 50C). Most oil degrading microorganisms are active in the mesothermic range of 20C to 35C and provide optimum degradation rates at these temperatures. Temperature will determine to a certain extent the types of organisms that will be present for degradation.

Temperature affects the rate of degradation. In general, degradation rates will be slower in colder waters than in warmer climates. At lower temperatures, the oil viscosity increases, the volatility of the lower chain hydrocarbons decreases, and solubility increases, making the oil more toxic and less appealing to degrading microbes.

Seawater ranges from -2C to 35C, with over 90% of the oceans having a temperature below 5C. Biodegradation has been observed in this entire temperature range. One experiment showed that a temperature drop from 25C to 5C caused a tenfold decrease in response rates (Leahy and Colwell, 1990). Degradation has been observed in Arctic ice and frozen tundra, but at negligible rates (Green, 1990).

Heat is released during degradation processes, but a fire by spontaneous combustion is not possible. Temperatures do not exceed 71C, the limiting maximum temperature for microbial survival. Higher temperatures would be required for most

products to ignite, but the chance remains small due to the volatilization of these molecules.

1.7 Moisture

Moisture is required for all biological processes to help transport nutrients, foods, and waste products in and out of the microorganisms. For oceans, lakes, and other surface water environments, this poses no immediate problems. For soil environments, some moisture must be present for degradation to occur. Too much water can impede the reaeration of the soil, and the process may turn anaerobic. The optimum ratio of moisture will depend on the climate and soil type. Ratios range from 30-90% in one study and 12-32% in others (Leahy and Colwell, 1990). Aerobic biodegradation of hydrocarbons in soils is greatest in ranges of 50-70% of the soil water holding capacity (Roberts, 1992). Whereas waves and tidal actions are useful in supplying aerated sea water to beaches and marshes, rainfall is useful in the biodegradation of inland soils by supplying moisture and useful dissolved oxygen to the microbes. Heavy rains, though, can impede the degradation rate if the area is allowed to flood for long periods of time.

1.8 pH Requirements

Microbe activity is affected by the pH of water and soil environments. The majority of hydrocarbon degrading microbes favor pH ranges of 6.5 to 8.5, with the optimum at 7.8 (Roberts, 1992). Fungi tend to favor environments with a pH below 6.0. For ocean environments, pH does not fluctuate widely, and ranges from 7.6 to 8.1 (U.S. Congress OTA, 1991). In salt marshes, the pH may be as low as 5.0, and thus reduced rates of degradation can be expected due to the lack of numbers of degrading microbes. Enhancement of soils below 6.0 to the 7.8 range may be required to stimulate the growth of microbes that otherwise could not compete effectively with the fungi. Lime is typically used to adjust the pH to near neutral.

1.9 Organic matter

The presence of naturally occurring organic matter can have different affects on soils, such as water retention, soil temperature, and the ability of microorganisms to degrade pollutants (Roberts, 1992). The role it plays in sorption processes can affect the availability of nutrients for the microorganisms. Contaminants targeted for biodegradation can be resistant of alter enzymatic attack by sorption onto soil particles. The bound material becomes unavailable for the attack. Addition of organic material can slow the natural rate of biodegradation due to increased competition, but long term it can increase infiltration and permeability and porosity (Green, 1990). The addition of the material can be helpful in low moisture retaining soil environments.

1.10 Oil surface and concentration

Since the majority of the biodegradation of hydrocarbons occurs at or near the air/water interface in water environments and the air/soil interface in soil environments, the amount of oil surface area exposed at these interfaces will affect the rate of degradation. The greater the area exposed, the faster the product will degrade.

Concentration of the hydrocarbon is related to oil surface area. Thick rafts, blankets, or pools of oil or other petroleum products constitute a high concentration/low surface area situation. The available sites that can be attacked are reduced. The oil acts as a blanket, hindering the replenishment of nutrients or oxygen to the microbes. Thus, at high concentrations those compounds most readily degraded will be attacked, leaving the more resistant components behind. These in turn combine to form even more resistant compounds, such as tarballs, that have limited moisture contact and surface area. Concentrations of hydrocarbons in the range of 1 to 100 ug/ml of water or 1 to 100 ug/g of soil (dry weight) are not generally considered toxic to common bacteria or fungi (Roberts, 1992). Thus, dispersants and emulsifiers used at sea on heavy

concentrations of oil increase the oils ability to spread and volatilize, which in turn allows for an overall increase in the rate of degradation, pending there are no adverse toxic effects of the type of dispersant used. Other means of removing heavy concentrations of oil and products should first be employed prior to remediation, such as using skimmers, vacuum trucks, adsorbents, and earth moving equipment.

1.11 Salinity

Microorganisms are typically well adapted to cope with the wide range of salinities common to the worlds oceans (U.S. Congress OTA, 1991). There is little evidence to suggest they are affected by other than hypersaline environments, such as saltwater from oil wells. Estuaries may present a special case because salinity values will vary in levels as compared to levels in the ocean (Okpokwasili,1990). Thus, if microbes are to be added to the environments, it must be known if they are compatible with the saline levels present in the system.

1.12 Summary of biodegradation basics

A variety of factors influence the rate of degradation of hydrocarbons by various microorganisms in oceans, lakes, and soil environments. Key factors required for optimum biodegradation include:

- a) a large consortium of hydrocarbon utilizing microbes;
- b) a continuous supply of dissolved oxygen, 3 to 4 ml for every 1 ml of hydrocarbon to be degraded;
- c) a sufficient source of nutrients including nitrogen, phosphorus, and other trace elements;
- d) a temperature between 20C and 35C for optimum degradation rates; lower temperatures will decrease the rate in most cases;
- e) a 50-70% moisture content in soil systems;

- f) a pH range of 6.5 to 8.5 to favor a larger consortium of hydrocarbon utilizing microbes;
- g) a sufficient amount of organic matter in dry soils to retain moisture;
- h) a high oil surface area and low concentration of product; thick pools, blankets, or open water rafts should be physically removed to decrease concentration and increase surface area for microbial attack, and allow for the replenishment of oxygen and nutrients;
- i) and a salinity range compatible when microbes are added to the system.

Section II

Sources, Composition, and Fate of Petroleum Products

2.1 Sources

The largest source of hydrocarbons found in the environment utilized by microorganisms are from spills created by man. The most widely publicized are those involving crude oil from supertanker accidents, such as the Exxon Valdez in Alaska, the Mega Borg off Texas, and more recently the Aegean Sea in Spain and the Braer off the Scotland Isles. Other sources of input include natural marine seeps like those off Santa Barbara Calif., offshore oil production facilities, atmospheric fallout, urban street runoff, petroleum refineries, pipelines, fuel facilities, underground fuel tanks, motorboat activity, ship operations, and onshore transportation accidents. It is estimated that the yearly global input of hydrocarbons from the above sources ranges from 1.7 to 8.0 million metric tons (Leahy and Colwell, 1990). Biodegradation of hydrocarbons by natural populations of microorganisms is one of the primary methods in which these pollutants are removed from the environment. The composition of crude oil and petroleum products will be discussed to understand the effects they have on degradation.

2.2 Hydrocarbon Classification

Oil is not a single, monolithic compound, but is actually a complex mixture of hundreds of compounds, the majority being organic hydrocarbons. This complexity has a tremendous effect on how oils and related products will degrade and behave in the environment. By weight, carbon makes up 80-87% of the elemental constituents found in crude oil, depending on the type of crude involved. Hydrogen (10-15%), nitrogen (0-1%), sulfur (0-10%), and other trace elements (<1%) make up the remaining percentages.

There are three classes of hydrocarbons used to describe the structure of the complex compounds found in oil products:

aliphatics, aromatics, and asphaltics (or asphaltenes/resins).

Aliphatic compounds are saturated hydrocarbons consisting of normal and branched alkanes (paraffins) and cycloalkanes (naphthenes). Most have 40 carbons or less, saturated with hydrogens at each bond. Aromatic hydrocarbons are one or more benzene rings consisting of 6 carbons and 6 hydrogens in a six sided ring shape. They are termed aromatics due to the aroma some possess. The most widely known aromatics are the benzene, toluene, and xylene (BTX) compounds. The multiple ring compounds can be either fused (sharing ring structures) or linked. Compounds with 3 or more rings are termed polynuclear aromatics. Asphaltics are high molecular weight polycyclic compounds with chains containing nitrogen, sulfur, and oxygen (NSO) compounds.

2.3 Crude classification

Crude oils can be classified in a variety of ways based upon the hydrocarbon content. Light crudes, those with a specific gravity of less than .85, have virtually all low molecular weight hydrocarbons that distill below 270C and have few NSO compounds, whereas heavy crudes have a specific gravity above .93 with high molecular weight compound concentrations that distill above 270C. Crudes between these two categories are labeled as intermediates (Cunningham, 1990). Another method is to group crudes according to the percentage of aliphatic hydrocarbons in the mixture (alkanes and cycloalkanes). Crudes with a total of 50% or more aliphatics are termed paraffinic, naphthenic, or paraffinic-naphthenic, depending on the dominant aliphatic. Crude oils with 40-45% aliphatics are termed aromatic intermediates, and crudes with 20-25% are termed aromatic -asphaltic or -naphthenic degraded oils (Green, 1990). The classification chart is presented in Appendix A.

2.4 Composition of petroleum products

Certain generalizations can be made concerning the composition of hydrocarbons in petroleum. The same generalizations can be formulated for the refined products distilled from crude. Understanding the composition of crude and refined product will have a bearing upon understanding the fate of the groups of hydrocarbons previously discussed when spilled into the environment. Those hydrocarbons that remain in the environment will be a determining factor in the rate at which microbes will attack and utilize the hydrocarbons. A general review of the composition of the most commonly spilled military and commercial products will be presented.

2.4.1 Crude oil

Crude oil is produced from various parts of the world. Properties such as viscosity, density, sulfur content, etc, will vary from crude to crude. Green, 1990, showed that 517 crudes sampled had, on an average, a composition consisting of 33.3% alkanes, 31.9% cycloalkanes, 34.5% aromatics, and the remaining percentage being NSO compounds. Cunningham, 1990, showed the composition of five common crudes, as presented in Table 2.

Table 2. Percent Composition of 5 common crudes.

<u>Crude</u>	<u>Aliphatics</u>	<u>Aromatics</u>	<u>NSO</u>	<u>Asphaltics</u>
Prudhoe	75	21	2	2
S. Louisiana	65	26	8	<1
Kuwait	50	32	16	2
Arabian	23	49	18	10
Californian	14	36	24	26

2.4.2 Kerosene

Kerosene is a product with a boiling range between 180C and 320C. Its composition depends on its source of material and manufacture, but usually contains 10 hydrocarbons compounds in the C10 to C16 range. A typical breakdown consists of 35%

alkanes, 50% cycloalkanes, and 15% aromatics. Kerosene is used for heating and in the production of jet fuel.

2.4.3 Fuel oil/diesel #2

These products are the fractions that distill after kerosene. Typical hydrocarbons range from C10 to C25. The product composition typically includes approximately 30% alkanes, 45% cycloalkanes (C12 to C25 compounds), and 25% aromatics. It is commonly used in combustion engines, furnaces, and boilers.

2.4.4 Gasoline

Gasoline has numerous hydrocarbon compounds in various proportions. The majority are the short chained C5 to C9 compounds with boiling points of 23C to 200C. The typical composition consists of 50-60% alkanes, 40% cycloalkanes, and 10% aromatics, with traces of sulfur, iron, and nitrogen (Roberts, 1992). It is most commonly used as motor fuel.

2.4.5 Jet fuel

Jet fuels are made by blending naphtha, gasoline, and kerosene to meet either military or commercial specifications. Two of the most common types produced are designated JP-4 and JP-5. JP-4 is widely used in commercial and U.S. Air Force aircraft. It has the highest hydrogen content, highest volatility, and lowest viscosity of the jet fuels used (Roberts, 1992). JP-5 is similar to JP-4, but is less volatile. It is widely used in Navy aircraft due to its higher ignition temperature. JP-4, with its lower ignition temperature, would be a much more serious fire hazard in the close confines of Navy ship. JP-5 adds an additional level of safety from fire hazards.

To fully realize the complexity of compounds in refined products, the many compounds found in fuel oil, gasoline, JP-4 and JP-5 are shown in Appendix A.1. A simple format displaying common products and carbon chain ranges is shown in Figure 1.

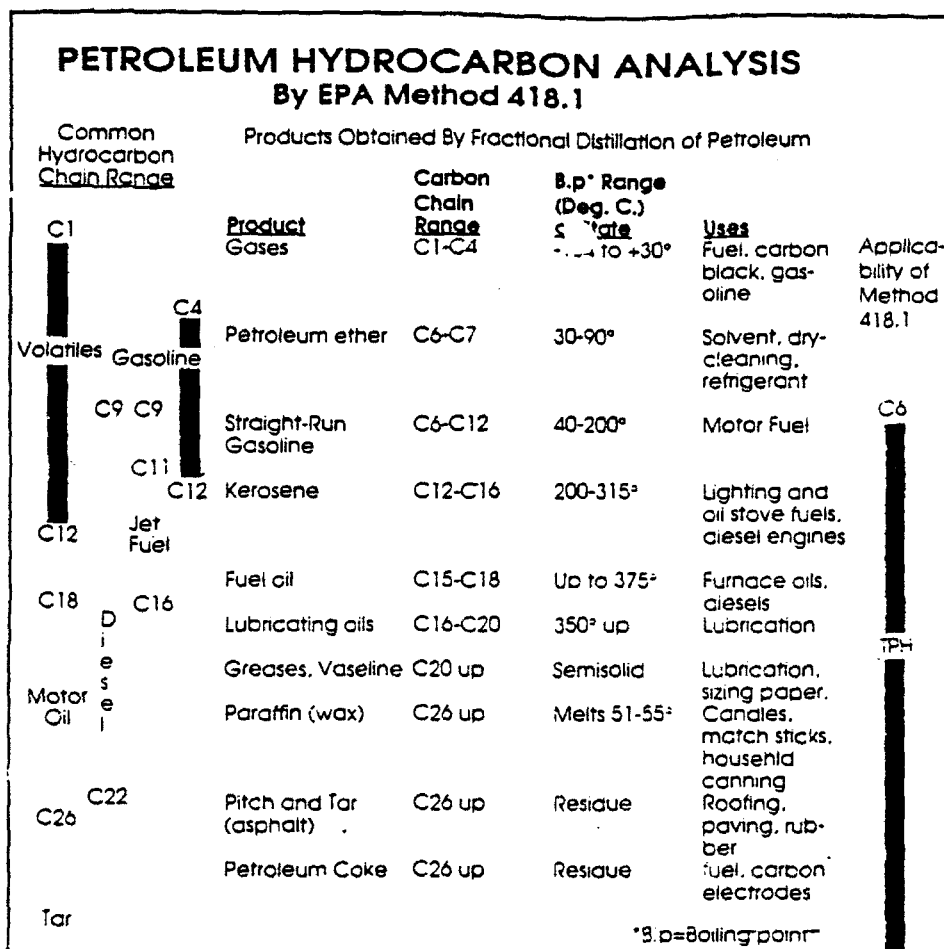

Figure 1. Common distilled petroleum products (unknown source).

2.5 Fate of oil and biodegradation effects

When petroleum enters an aquatic environment, surface or subsurface, it will be subject to many physical and chemical factors that will contribute to the loss or alteration of the hydrocarbons that will, in turn, have an effect on degradation rates. The overall affect of the many factors is called weathering. The fate of the hydrocarbon in the environment is determined by the characteristics and properties of the molecules and of its surrounding environment. The effects of spreading, evaporation, dispersion, emulsification, density, solubility, sorption, and chemical structure on degradation rates will be discussed.

2.5.1 Spreading

When oil or product hits water, it tends to form a slick. This process is called spreading. It can be the dominant process up to 10 hours after the initial spill (Green, 1990). Although spreading is not desirable for mechanical cleanup processes, it is desirable for microbial attack by reducing the concentration of the oil and increasing the air/water/oil surface interfaces that promote degradation. The rate of spreading depends on the initial inertia of the spill, gravity, surface tension, and viscosity of the oil, as described by J. A. Fay in 1969. As the viscosity of the product decreases, the spreading increases, as seen in the difference sizes of slicks caused by an equal amount of gasoline and a heavy crude oil. The resultant spread increases the surface area and enhances the processes of evaporation, dispersion, and photolysis. Sunlight can warm the slick, increasing evaporation, providing a more suitable temperature range for hydrocarbon utilizing microbes, or increase the rate of spread, depending on the pour point of the product.

2.5.2 Evaporation

Evaporation starts at the onset of product release and involves the loss of the volatile hydrocarbon molecules in the

mixture. Green, 1990, reported that all n-<C15 alkane compounds evaporate within 10 days, with a slower rate for n-C15 to n-C25 compounds, and no significant loss by evaporation for n-C25 and above compounds. The rates of loss depends on the type of products: gasoline will evaporate up to 90-100% of the original amount spilled, #2 fuel oil 75%, crude oil 30-50%, and Bunker C 10% (Green, 1990). Low boil point aromatics, with low vapor pressures, evaporate more slowly than the normal and branched alkanes, which have a greater vapor pressure. As weathering continues, product with aromatics and high molecular weight fractions will concentrate to form the dominant compound.

Factors that affect evaporation include agitation by wind and waves, air and water temperatures, properties of the product itself, and spreading. Evaporation can be helpful to biodegradation by driving off some of the below C9 alkanes that tend to be toxic to the microbes in high concentrations, but can also be detrimental by reducing the concentration of the easily degraded compounds. Products released into the soil may not undergo evaporation quite readily due to the lack of an air interface.

2.5.3. Dispersion

Dispersion is the disruption of oil into tiny droplets or particles in the water. Its importance in destructing a slick is apparent by the use of dispersants. Biodegradation can be enhanced from dispersion by providing more surface interfaces which can accommodate microbial attack. The main draw back is it can result in high concentrations of dissolved hydrocarbons below C9, which can be toxic, as previously mentioned.

2.5.4 Emulsification

Emulsification is the term used for the formation of water in oil emulsions, which is commonly referred to as chocolate mousse. The process is dependent on the type of product and the prevailing weather conditions. Crude oils high in asphaltics and refined products, such as fuel oil, are most likely to form

water in oil emulsions (Editor, Offshore, 1991). As the evaporation of volatiles at the onset of the spill recedes, emulsification takes over. Oil emulsions containing up to 80-90% water are common and are quite stable because water trapped inside the emulsion contains too little oxygen to support biodegradation. Some degradation is possible and does occur, but can lead to the formation of tar balls which eventually can sink or be deposited on shore fronts. The emulsified oil could sink to the bottom sediments where further biodegradation could continue, providing ample oxygen and nutrients exist at these depths.

2.5.5 Density

Density of the product is important when understanding the movement in soil and groundwater. Density differences of 1 percent can influence fluid movement in the subsurface (Roberts, 1992). Density determines whether a contaminant will migrate in an aquifer system. Low density hydrocarbons with specific gravities less than 1 (water) will float in the upper regions, while high density compounds will sink to the lower portion. A product, such as gasoline would migrate vertically through the soil then float on the water table, spreading toward the down gradient direction (Roberts 1992). Two additional factors that affect migration are solubility and sorption.

2.5.6 Solubility

Hydrocarbons differ in their solubility, from miscible compounds such as methanol, to extremely low soluble compounds such as the high molecular weight polynuclear aromatic hydrocarbons (Roberts, 1992). The availability of the compound to the degrading microbes will determine its biodegradability. Compounds that have greater solubilities in water will generally be more available to degradation by increasing the oil/water/air surface interfaces. Surfactants and dispersants can increase the solubility of the compounds, and thus increase the rate of

degradation. Solubilities of compounds in seawater will be lower than those in freshwater due to the salting out effects of seawater.

The migration of contaminants in ground water depends on the solubility of the compound and organic content present in the aquifer. Less soluble compounds can be attracted to the organic matter in the aquifer and cease to migrate. Density and viscosity determines whether the compound will flow, mix, or sink in the aquifer. Some slightly soluble compounds, such as benzene, will form plumes that can overlap other plumes of different compounds. The overlap can have an effect on the degradation activities of certain microbes by competition and could decrease the degradation rate.

Due to the effects of dispersion and diffusion, organic compounds are rarely found in groundwater at concentrations approaching their solubility limits (Green, 1990). Therefore, the volume of water polluted can be greater than originally estimated. Also, those products that evaporate quickly on surface waters tend to be more soluble. Thus, in restricted gaseous regions, such as groundwater and under ice, these compounds may reach higher concentration due to lack of evaporation. If evaporation is restricted, the dissolved components will more likely be degraded by other means, such as chemical or biological processes (Green, 1990).

The solubility of common petroleum constituents in water is shown in Appendix B.

2.5.7 Sorption

It has been shown that many constituents of petroleum have the potential to be bound to various forms of particulate matter found in aquatic environments (Leahy and Colwell, 1990). This binding can have an effect on the ability of the microbe to degrade the compound.

Binding depends on the physical nature of the compound, the nature of the particle or its surface, and the nature of the medium. Particles such as clays, silts, organic matter,

minerals with organic coatings, and small organisms are implicated in the binding process (Green, 1990). Oil can be absorbed into the material, or it may be adsorbed onto the surface. Binding can affect the density of the product causing it to sink. Binding can stabilize the compound making it more vulnerable to attack, or it can protect it from the degradative process. It also plays a role in determining how components migrate in soils and ground water. In general, aromatic hydrocarbons and related compounds are more susceptible to binding than the aliphatics and tend to be the limiting factor of migration in soils (Roberts, 1990). If aromatics cannot migrate towards areas of oxygen and nutrients, they will persist in the environment.

2.5.8 Chemical structure

The structure, toxicity, and concentration of a compound are important in determining whether it will be degraded or whether it will persist in the environment. The compound will remain in the system if it prevents degradation by organisms. This may be due to its insolubility, or can be attributed to its structure by which microorganisms have no means or surfaces to attack. Compounds that are man made or exist naturally in the environment but exceed natural normal levels are called xenobiotics.

Structure will affect biodegradation in two ways: the compound may contain groups of chemical bonds that cannot be broken with the available enzymes produced by the microbe, or the structure may determine the compound to be in a physical state (adsorbed, gas, etc) where degradation does not readily occur (Roberts ,1992).

Generally, the larger and more complex the structure of the compound, the more slowly it is oxidized. For oil products, the order of classes from most to least degradable is aliphatics, aromatics, then asphaltics. The degradation is dependent on the microorganisms present and environmental conditions as discussed in Section I. More specifically, the order of compounds from

most to least degradable (under aerobic conditions) is straight chained alkanes (C10 - C16), gases (C2 - C4), straight chained alkanes (C5 - C9), branched alkanes up to C12, aromatics, then cycloalkanes (Roberts, 1992 and Green, 1990). These compounds undergo oxidation to form various alcohols, aldehydes, and fatty acids, which in turn are utilized by other organisms in the chain. The types of hydrocarbons and corresponding microbe species capable of degrading the contaminant are listed in Appendix C.

The C2 to C5 or 6 alkanes, in sufficient concentrations, are inhibitory to some of the microorganisms because the size of the hydrocarbon allows them to penetrate the cell by solvating and destroying the membrane (Green, 1990). Liquid hydrocarbons such as n-alkanes, cycloalkanes, and aromatics with carbon numbers under 10 all share this property to varying degrees. The concentration of these compounds interferes with the biodegradation. The low molecular weight compounds that are toxic are generally also volatile. Therefore, it may be possible to modify the composition of the product to make it more susceptible to degradation. The low molecular weight toxic compounds can be removed from open water naturally through weathering, or can be accelerated by burning or agitation. More advantageous actions would be to recover the majority of the spilled product, mechanically or physically, thus reducing the concentration to acceptable levels for degradation.

2.6 Summary

The composition of and fate of the compound in the environment will affect the rate at which it will degrade. Petroleum products are made up of three classes of hydrocarbons: aliphatics, aromatics, and asphaltics. The rate of degradation from most to least is the same as previously described. The factors that affect biodegradation are summarized below.

a) Light crude oils with high percentages of aliphatics will be easier to degrade than heavier crudes that contain high

percentages of asphaltics. Kerosene, gasoline, fuel oil, and jet fuel have high concentrations of aliphatics and aromatics, and will be more susceptible to degradation.

b) The fate of product, once released, will affect the rate of degradation. As time passes and the product weathers, easily degradable compounds will evaporate or biodegrade, leaving less degradable compounds to concentrate and persist in the system. Spreading can help by reducing the concentration of product. Elevated concentrations may have toxic effects and, spreading tends to increase the oil/water/air surface interfaces for more microbial attack. Dispersion of product can increase degradation much like spreading by reducing concentration and by producing small droplets with greater oil/water surfaces. Emulsification can inhibit degradation and cause the product to sink. Compounds that are soluble tend to be easily degradable due to accessibility to the organisms. Insoluble compounds tend to persist and increase their relative concentration in the remaining product. Density and sorption will affect the migration of compounds in soil and groundwater systems and can decrease the degradation process, as well. Finally, the chemical structure and physical properties of the compound itself will determine the susceptibility to degradation. The larger and more complex the compound, the least favorable it will be to degradation. Low molecular weight compounds that are easily degraded are also usually those that are most volatile. Therefore, it is important to consider the aspects of Section I and combine them with the aspects of Section II to help fully understand if biodegradation can be used as a clean up technology for a given spill site.

Typical degradation rates, initial and final concentrations of contaminants, and organisms used to degrade given contaminants are shown in Appendix D. The chart shows the wide range of possibilities using biodegradation as a treatment technology.

Section III -
Bioproduct and Application Technology

3.1 Introduction

This section will describe the current technologies used in bioremediation of hydrocarbon spills. The first part will introduce common, commercially available biostimulants. Four were used on the Exxon Valdez spill under experiments conducted by the EPA, and one product was used on the 1990 Mega Borg incident. The second part of the section will present the technologies used to apply these products to the affected sites. A matrix will be developed to show which technologies are suitable and should be considered for a given spill situation.

Bioremediation of hydrocarbon spills is not the magical cure-all solution to clean up procedures. Instead, it should be incorporated into the overall plan when combatting a spill. Although stimulating naturally occurring microorganisms produces much faster degradation rates, the process still is slow in producing the short-term results response managers desire, as shown in Appendix D. As shown in prior sections, bioremediation is not an appropriate, first line of defense measure for large spills of high concentration, non-weathered compounds. First line of defense measures will continue to be those technologies that skim, vacuum, disperse, or burn the spill to reduce concentrations and the amount that will foul beaches, marshes, and ports.

Bioremediation conditions will be different from site to site and product to product, thus, the technology must be tailored to the contaminant and the environmental characteristics of each spill site. Just as it is appropriate to determine the proper skimmer for a certain crude oil, it will be appropriate to determine if the requirements for bioremediation are available in the environment. The type of compounds to be degraded, location, temperature, type of indigenous microbes, and other previously mentioned factors will

all need to be analyzed to determine if this technology will be feasible. The controversy that looms over the use of chemical dispersants for oil spills rears its ugly head toward bioremediation as well. The public's unfamiliarity and lack of knowledge of bioremediation processes affects the acceptability of its use. Before bioremediation becomes widely accepted, the public must be convinced, as well as the scientific community, that the efficiency and safety to the environment using natural solutions can be demonstrated.

Bioremediation has many advantages that will encourage future use. It involves minimal disruption of the site, the current research shows minimal adverse effects on the surrounding environment (as compared to dispersants, high pressure cleaning, steam cleaning, manual scrubbing), it can reduce the amount of waste disposed, and it requires simpler, less labor intensive equipment and logistics (U.S. Congress OTA, 1991). Negative aspects to bioremediation do exist and are continuing to be researched in the scientific community.

3.2 Bioproduct technology

In formulating this report, a literary search was conducted to review the many biostimulants commercially available for use on hydrocarbon spills. Of the 13 companies contacted, five responded with literature on their product. It was intended to obtain as much data on the physical properties of each product so as to review the type of equipment needed to apply the product.

It became apparent that the majority of the companies were not interested in sending information to a major research university. Each company was sent three letters requesting information. If there was no response by the third letter, the company was dropped from the list. Some of the companies that did respond were merely consultants in the field and did not manufacture biostimulants, but used these commercial products in their remediation project. Of the five companies that

responded, all are listed on the EPA's National Contingency Plan Product Schedule. The majority of the companies that did not respond had products that were not listed on the EPA's Schedule. While no product on the Schedule is endorsed by the EPA or this report, response managers should be cautioned to the many products available on the market. By understanding the basics of biodegradation and the rates at which hydrocarbons degrade, mistakes can be avoided by not purchasing magical snake oils with exaggerated performance claims.

3.3 Bioproduct Classification

Bioremediation products can be classified into three basic categories: 1) nutrient enrichment (nutriation), 2) seeding with naturally occurring microbes, or 3) seeding with genetically engineered microbes (GEMs) (U.S. Congress OTA, 1991).

Of the three classes, scientists believe nutrient enrichment is the most promising approach to use for oil spill situations. The approach involves the addition of nutrients, described in Section I, that may be limiting the microbial degradation process. Since microorganisms that can degrade hydrocarbons already occur in the environment, the rationale to nutriation is to increase the population and thus increase the rate at which the compounds are consumed. There are three common types of nutrient supplements: water soluble, slow release, and oleophilic. These three types were recently used in field experiments conducted by the EPA during the Valdez disaster. The results provided a wealth of data and showed evidence that nutrient enhancement could significantly increase the rate of degradation on and below the soil surface. Although no open water experiments were conducted using nutrients, seeding was tried on the Mega Borg disaster with mixed results.

During the Valdez experiments, soil populations were shown to increase 3-4 fold upon initial applications for up to 32 weeks. Additional applications showed an increase of 4-5 fold during

the same period (Nichols, 1992).

Seeding , or inoculation, is the addition of microbes to the polluted environment. The inoculum would consist of non-indigenous microbes from various polluted sites, specially selected for their oil degrading characteristics. Or, they may be a blend of microbes selected from the site to be remediated and mass cultured in the lab or in a bioreactor (U.S. Congress OTA, 1991). The rationale is to increase the types of microbes that will degrade oil products that many not be initially present or are lacking in the system. The addition of nutrients would still be required in order to increase the population, thus increasing the rate of degradation. Advantages to this method are that blends could be customized for different types of spilled compounds, nutrition requirements would be better understood, and that microbes can be mass produced and stored for faster use (U.S. Congress OTA, 1991). Microbes capable of hydrocarbon degradation are presented in Appendix C and Table 1.

The use of genetically engineered microbes to degrade oil products is not widely practiced largely in part due to the ability of many naturally occurring organisms to degrade hydrocarbons. The rationale behind the method is to produce microbes with higher degradation efficiencies than naturally occurring microbes, or to degrade the more persistent compounds not readily degraded by natural microbes. The major objections for using GEMs, according to the OTA, are lack of research and shared data, and regulatory hurdles.

3.4 BioProduct review

The five companies that provided product literature manufacture a variety of bioremediation products that fall under either the nutrient class or the seeding class. Since little data exists, no company provided literature on genetically engineered microbes.

Medina Biological Remediation Services of Hondo, Texas

manufactures three nutrient enhancers and one seeding formula. Their Microbial Activator contains micronutrients which assist in macronutrient and hydrocarbon assimilation and degradation. It is a non-toxic, clear liquid mixture with a viscosity comparable to water. The bulk price is \$440 per 55 gallon drum. One gallon mixed with 5 gallons of natural water will treat 1000 sq. ft. of soil. Bio-D is a source of macronutrients complexed with digested organic complexes. It is a non-toxic, thick clear liquid that contains humate, nitrogen, potassium, and phosphorus. One quart mixed with 5 gallons of natural water will cover 1000 sq. ft. Cost per 55 gallon drum is \$643.50.

D-Part is a biological enhancement product that stimulates indigenous and non-indigenous microbial populations. It is similar to Microbial Activator, but is formulated for water environments. One gallon mixed with 5 gallons of natural water will cover 1000 sq. ft. It is a clear liquid and costs \$753 per 55 gallon drum.

Medina also produces a microbial seeding product called D-Grading Bacteria. When mixed with natural water, the microbes are activated producing non-pathogenic strains that degrade hydrocarbons in soil and aqueous environments. It is supplied in 25 pound buckets. It is a dry bran mixture, that if mixed with water and sprayed using nozzled equipment, should be settled and filtered prior to use. It costs \$950 per bucket. One pound mixed with one gallon of natural water will cover 1000 sq. ft. All Medina products operate in the optimum range for growth requirements: a pH of 6-8.5, a temperature of 35F- 90F, for salt, fresh, and soil environments. All products are listed on the EPA's Product Schedule and were evaluated during the Valdez disaster. The information on product performance is shown in Appendix E. Data for the 11 and 20 day reduction of alkanes was provided, but no data was provided on the reduction of aromatics or higher molecular weighted hydrocarbons. Further research would be required to determine its overall effectiveness on the wide range of constituents in petroleum

products. It reports that the mixtures can be applied at any time during the spill. It is helpful in reducing the initial volatile compounds, thus reducing the chance of fire.

Elf Aquitaine of Paris, France, manufactures an oleophilic nutrient enrichment product called Inipol EAP 22. Its chemical makeup consists of oleic acid, urea, lauryl phosphate, 2 butoxyethanol and monobutyl. It is a clear liquid, with a specific gravity of .996, a viscosity of 250 cSt, a pour point of 11C, and a flash point of >100C. It is packaged in 200 kg steel drums for shipment. No cost data was provided with the literature, but the EPA spent over \$11 million on the product during the Valdez trials. It is applied in dosing rates of 3-6% of the amount of oil present for optimum biodegradation results. Since it is oleophilic, Inipol EAP 22 is insoluble in water and thus will adhere to the oil surface, readily available for microbial use. This feature allows it to be used in any weather condition, for it will travel with the slick. It is reported to be effective against any petroleum product and the weathered "chocolate mousse" mixtures. It operates in all temperature ranges that indigenous microbes operate, thus it is not temperature dependent. Since its pour point is 11C, Elf manufactures EAP 22F for colder climates. Its pour point is -4C.

Although it is biodegradable and non-toxic to marine life, the 2 butoxyethanol is toxic to humans and its use is regulated by OSHA. Care should be exercised when applying the product. Respirators should be used to minimize exposure due to inhalation or ingestion. It can be absorbed by the skin and causes irritations. Symptoms of exposure include dizziness, headaches, respiratory, skin, and eye irritations, paleness, and urine discoloration. Long term effects include blood and kidney damage.

Inipol EAP 22 was used extensively in the Valdez experiments. It is listed on the EPA Product Schedule. The data on its performance on various crudes is shown in

Appendix F. It can be applied at anytime during the spill. The EPA reported "essentially oil free white rocks ten days after application" during the experiments. These removal rates are comparable to the data shown in Appendix F.

Sky Blue Chems of Dallas, Texas manufactures a product called Oil Spill Eater (OSE). It is a combination nutrient enrichment and seeding product, labeled as a biocatalytic, multienzyme, liquid concentrate consisting of water, molasses, malt, yeast, sugar, and oleophilic surfactants. It is non-toxic, has no hazardous components, a specific gravity of 1.05, is brown in color, and is as viscous as motor oil. It is packaged and shipped in 55 gallon drums and has a 5 year shelf life. It costs \$7755 per 55 gallon drum. One gallon is mixed with 50 gallons of natural fresh or sea water for application on spills. The literature claims one drum of OSE diluted with 50 drums of water will eliminate 2750 gallons of crude oil, but did not mention the time for degradation nor to what degree. Its reaction mechanism is similar to that of Inipol EAP 22, where the mineral nutrients in the oleophilic surfactant dissolve into the hydrocarbon matrices by aid of the enzymes. The nutrients enhance indigenous growth and increase biomass, which degrade the hydrocarbons. Its optimum temperature range is 40F-85F, but is still effective in the 28F-120F range. Effective pH range for stability and reactivity is 3.4 to 9.5.

It is non-toxic to humans and marine life, even if ingested. It is non-irritating to skin or eyes, and no special protective equipment is required for application. It can be used to clean birds, and assists in controlling odors and fire hazards. Since it is oleophilic, it travels with the slick where ever it may spread. The literature claims that once rocks and shorelines are sprayed with the OSE mixture, oil will not attach to the surfaces. No specific performance data or degradation rates were included in the literature. OSE is on the EPA Product Schedule.

Two companies that responded manufacture microbial seeding

products. Waste Microbes, Inc. of Houston, Texas, produces a microbial product called WMI-2000. The product consists of bacterial cultures selected from isolated areas where contamination was employed as the food source. They are naturally occurring, non-pathogenic, and are non-toxic to humans and marine life. The mixture consists of a tan/brown flowable powder, density of 4-4.3 pounds per gallon, and has a mild yeast-like odor. Growth requirements include a pH range of 6-8.5, an effective temperature range of 35F to 100F, minimum oxygen levels of 2.0 mg/l, and nutrient levels of 5 to 20 ppm for nitrogen and 1 to 5 ppm of phosphorous. It claims to have a bacteria count in excess of 5 billion microbes/gram. No cost or packaging data was supplied with the literature. It is non-toxic to humans and marine life, but care should be exercised not to breathe the dust. No adverse health effects have been reported.

Unlike Oil Spill Eater, WMI-2000 does not provide a nutrient supplement in the microbe mixture, and thus nutrients must be obtained from additional sources. The company suggests using 25-12-0 commercial fertilizers at a rate of 160 pounds per acre. WMI-2000 is soaked in natural waters for 2-4 hours prior to application to activate the product. One pound of mixture is required for every 2 or more gallons of water. It is applied at the rate of 1 pound (dry) or 2 gallons (mixed) per 700 sq. ft. or 50 pounds or 100 gallons mixed per acre. The product has been used extensively by the company for soil remediation projects throughout the United States. No specific performance data were provided. Applicable uses are shown in Appendix G. It was used in the Valdez experiments and is listed on the EPA Product Schedule.

The second company that manufactures microbes for seeding is Oppenheimer Environmental Company of Austin, Texas. It manufactures a microbial product called The Oppenheimer Formula. The formula is similar to OSE and consists of naturally occurring communities of microorganisms selected from

contaminated soil and waste environments. It is blended with essential growth nutrients. The microbes range in size from 1 to 10 microns and were selected for their affinity for oil. The product is a dry powder sold in 10, 20, and 25 pound containers. It has a 5 year shelf life, an effective temperature range of 35F to 120F, and an effective pH range of 5.5 to 10. No other nutrient sources are required since they are incorporated in the mixture. The product is non-toxic to humans, fish, or wildlife. No specific data on application rates, cost, or specific performance was provided but is being requested. The product was recently used on the June 1990 Mega Borg oil spill in conjunction with the Texas Land Office, with mixed results. It is on the EPA Product Schedule. The companys project list and partial performance data is shown in Appendix H.

3.5 Application technology

The various types of equipment used to apply bioremediation products are quite simple in design and easy to use. Virtually all the technology used in applying dispersants can be used to apply bioremediation products. The availability of an adequate supply of application equipment and delivery platforms, as well as trained personnel, are the main components in the logistics of dispensing bioremediation mixtures. The physical characteristic of the products and size and location of the spill will largely determine which equipment or delivery platform will be used. The success of bioremediation depends on the amount of product that can be delivered to the target contaminant. And since the product, when used in large quantities, is not cheap, placement will also have an effect on overall cost.

Hydrocarbon spills can happen anywhere at any time. Each of the products in this report and those listed in the EPA Product Schedule are available in different quantities and at different locations. It is unlikely that oil spill co-ops or large pollution contractors would carry any amount necessary to combat a spill due to lack of knowledge or uncertainty of the

product, or that most of the products have a short shelf life. If this technology is to be used effectively, response managers must locate potential suppliers, determine lead or minimum times for ordering and delivery, and include this information in the local contingency plan.

The technology for the application of bioremediation products comes in two forms: equipment and delivery platforms. Equipment is considered to be the mechanical device or devices that dispense the product and include spray boom and assemblies, flowmeters, nozzles, pumps, eductors, tanks, hoses, pipes, mixing vats, and so forth. The term delivery platform describes the means by which the equipment is transported to the contamination site for use in applying product. The three major categories of platforms are aircraft, boats, and land vehicles. Equipment can be mounted on, in, or to delivery platforms. Non-permanently mounted equipment, especially packaged units, can be stored until needed, thus keeping a costly delivery platform available for other uses during the life of the spill.

The equipment or delivery platform for application are available from a variety of sources. They can either be purchased or leased. Since each product to be dispensed has an optimal application rate, application equipment must be designed or modified to produce these rates for a given surface speed of delivery or for a given sweep/spray width. Just as with locating bioproducts, response managers must identify the availability of both application equipment and the types of delivery platforms and include this information in the contingency plan. Those platforms that can be quickly converted for different missions will be the most cost effective during the long term spill response.

3.5.1 Delivery platforms

The three delivery platforms most commonly used in oil spill responses are aircraft, boats, and land vehicles. Location of the spill will be a crucial factor in determining if the platforms are available, or can be used at all. Remote spill

sites offer the most difficulties, usually resulting in lack of airport facilities, availability, or physical access to the site. These problems should be reviewed and addressed in the local contingency plan.

Virtually all the platforms used to deliver dispersants to spill sites can be used in the delivery of bioremediation products as well. The advantage to this process is that since dispersants need to be applied within days of the initial spill in order to be effective, the bioproducts can be dispensed after dispersant application is no longer effective, using the equipment and delivery platforms with minimal modifications. Thus, there will be an optimal and efficient use of expensive delivery platforms during the life of the spill. Also, the time required for applying dispersants can be used to purchase and deliver the bioremediation products and have them ready for use once equipment becomes available.

3.5.1.1 Aircraft

Aircraft, including rotary and fixed winged, have many advantages for use as delivery platforms: good aerial visibility for spotting slicks, fast response to the site, and a high treatment rate. For aircraft to be suitable, they should be able to operate at low altitudes, low speeds, have good maneuverability and carry large payloads of bioproduct. Spray aircraft come in two categories: those built specifically for agricultural use and those that are converted for dispersant applications for oil spill response.

Agricultural sprayers, known as crop dusters, are common throughout the United States and are well suited for the application of liquid products. They are primarily used in aerial pesticide spraying and for mosquito control. Converted aircraft will be more limited in availability, and some aviation firms throughout the United States specialize in these planes. The limited number is due in part to the limited requirement of such aircraft and the cost of conversion.

The most readily available aircraft is the helicopter.

They can operate from just about anywhere and are useful in confined and remote locations. They can be used with either installed tanks and spray booms or can carry underslung bucket and boom packages. Cargo weight and limited range are the two important factors for helicopters. Typical capacity of product ranges from 400 to 2000 liters (100 to 500 gallons). Helicopters are used at best efficiency with bucket packages when fully loaded spares are available for immediate pickup. The craft should be fitted with quick release latches to speed the exchange. When not used for spraying, helicopters can be used to ferry men, equipment, and additional product to the spill sites, increasing their overall effectiveness.

Helicopters used by the U.S. Forest Service for fire fighting are well suited for this type of operation. Contractual arrangements can be made through this agency for use of these helicopters or for possible locations of operators.

The most widely used helicopters for aerial applications include the Bell 206 or H-57 Ranger, the Bell UH-1 Huey or the Bell 212 (used in offshore oil operations), and the Aerospatiale H-65 Dolphin currently used by the U.S. Coast Guard. Both military and commercial versions of these helicopters exist, and performance characteristics are virtually the same for each. Costs can vary from \$400-\$1500 per hour, depending on the craft and the length of time in service.

Recently, the development of the Bell/Textron V-22 Tiltrotor Osprey has shown promise for use in oil spill response. Labeled a vertical take off or landing aircraft (VTOL), it has the capability of maneuvering like a helicopter or like an airplane, depending on the tilt of its large rotors. It has a speed of 350 mph, a range of 1200 miles, and can carry a 10 ton payload in its rear cargo area. Its current problem is that it is still under development and has limited production, and thus it is quiet expensive. The V-22 and other helicopters commonly used for aerial spraying are shown in Appendix I.

Small fixed wing aircraft are advantageous to use as

delivery platforms because of their high endurance, low fuel consumption, airspeed, turnaround times, and ability to operate from short, even improvised landing areas. They are ideal for use on small or fragmented slicks and near shorelines. They are limited by the tank capacity and range at which they can operate. Because the majority of these type of aircraft are designed to spray fine mists of agricultural products, they may require nozzle changes to allow higher application rates as required by the bioproduct and to allow larger droplet sizes to minimize drift and evaporation.

Common small wing agricultural aircraft found in the United States include the Cessna Agtruck, the Piper Pawnee, and the Ayres Thrush Turbo and Thrush Commander. Converted small wing aircraft include the Beech Baron and Piper Aztec. Tank capacities range from 600 to 2600 liters (150 to 700 gallons). Costs per hour depend on the aircraft used and can range from \$200- 750. No small wing military aircraft exist for this purpose nor could they be modified.

Larger, multiengined, fixed wing aircraft include the DC-3, DC-4, DC-6, and C-130 Hercules. Their tank capacities range from 6000 to 20000 liters (1500 to 5500 gallons). The larger payloads and faster application rates make them suitable for offshore spills. Since these are specialized aircraft, start up costs, standby fees, and operating expenses must be considered. Typical large and small wing aircraft used in aerial applications and performance specifications are shown in Appendix J.

3.5.1.2 Boats

Boats are useful in the application of product because they are widely available, easily modified, have considerable residence times and have significant tank capacities for product. Simple pumping and tank storage arrangements can be made at little expense. The drawbacks to using boats include poor visibility for locating slicks, and a relatively low areal coverage per unit of time. Spotter aircraft are usually

employed with larger offshore supply vessels to increase effective visibility. Thus, large boats can be used in open oceans, but medium and smaller boats are best suited for use in confined areas, near shorelines, and for small spills.

Boats can range from small outboards to large offshore supply vessels. The type of vessel used will depend upon the location of the spill. For open oceans, offshore crew boats, tugs, and supply boats fitted with tanks and spray booms would offer a safe means by which to apply product. Similar medium size vessels are appropriate for near shore slicks, harbors, and inlets, that are not limited by draft. Small pontoon boats, flat bottom jon boats, and air powered boats with shallow drafts would be suitable for near shore operations, shallow water and marshes affected by tidal movements, rivers, and creeks. Tank capacities are limited to the boat size, but can range from 500 to 80,000 liters (125 to 22,000 gallons). Tanks may be permanently mounted or removable, making the vessels available for other uses.

Product can be dispensed through the firepumps and hoses available on the larger vessels, or can be dispensed from packaged tank units mounted in the smaller craft. The boats can also be used to transport the bioremediation product and stockpile it at sites not accessible by planes or helicopters. Tank barges could be used to store, transport, and dispense product, but would require the use of a tug or other similar powered unit. Possible vessels of opportunity to be used as delivery platforms are shown in Appendix K.

Motorized landing craft or LCs, used by military amphibious units, are well suited for oil spill response platforms. The shallow draft, large, open deck area, heavy roll on roll off payload capability, and maneuverability make them ideal for accommodating dispensing equipment. Packaged units could be temporarily employed in the bay, or tanker trucks filled with bioproduct could be rolled on or off any improvised shoreline. The LC simply returns the empty tank truck to base

and returns with a fully loaded tank. -Turn around time depends on the speed which the truck can be on and off loaded, and the time enroute to the site. LCs come in various sizes, but usually have speeds of 8 to 10 knots and payloads of up to 60 tons. Their ruggedness and large payloads make them suitable for working at remote beachfronts, shorelines, marshes, in harbors, and near jetties and pier structures. As current military forces draw down from the cold war, many units could become available from surplus outlets. Typical landing craft are shown in Figure 2.

3.5.1.3 Land vehicles

Any rubber tire or tracked vehicle capable of holding a tank and pump is a suitable delivery vehicle for applying bioproducts. Tanks can be permanently or temporarily mounted. The most commonly used are pickup trucks, flatbed haulers, vacuum trucks capable of reverse flow, water tankers used in highway construction, and other specialized vehicles. Vehicles should be equipped to handle large payloads and have high floatation tires or tracks so as to not sink in soft, saturated soils. Units are available from commercial suppliers and can be purchased or leased. Costs can range from cheap to very expensive and leasing should be considered.

One specialized platform is manufactured by Ag-Chem Equipment Company, Inc., of Minnetonka, Minnesota. Called the Terra-gator, this tank vehicle, Figure 3, is manufactured in 4 models with capacities ranging from 2000-4000 gallons, Appendix L. Equipped with rear end dispensing and aerator attachments, these four wheeled drive, high floatation rubber tired vehicles can till and inject, in depths to 16", up to 170,00 gallons per day of product. The platforms are suitable for soft sand beaches, cobbled shorelines, marshes, and off road areas where conventional equipment may get bogged down.

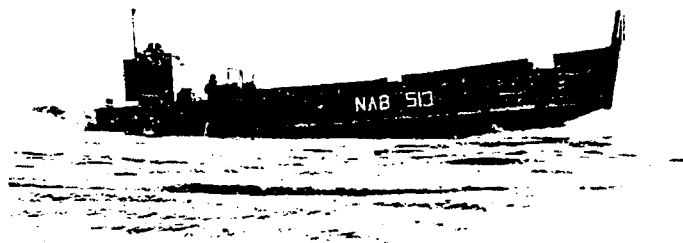

MECHANISED LANDING CRAFT: LCM 8 TYPE

Displacement, tons: 115 full load (steel) or 105 full load (aluminium)

Dimensions, feet (metres): 73.7 x 21 x 5.2 (22.5 x 6.4 x 1.6)

Main engines: 2 diesels (Detroit or General Motors), 2 shafts; 650 bhp = 9 knots

Complement: 5 (enlisted men)

Constructed of welded-steel or (later units) aluminium. Can carry one M48 or M60 tank (both approx 48 tons) or 60 tons cargo, range is 150 nautical miles at full load. Also operated in large numbers by the US Army.

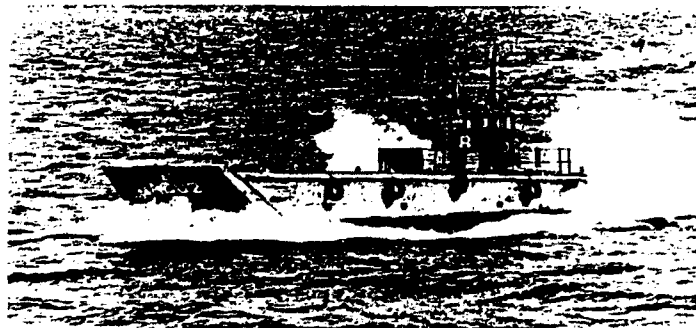

Figure 2. Typical landing craft (Janes, 1987).

Vehicle shown in transport mode.

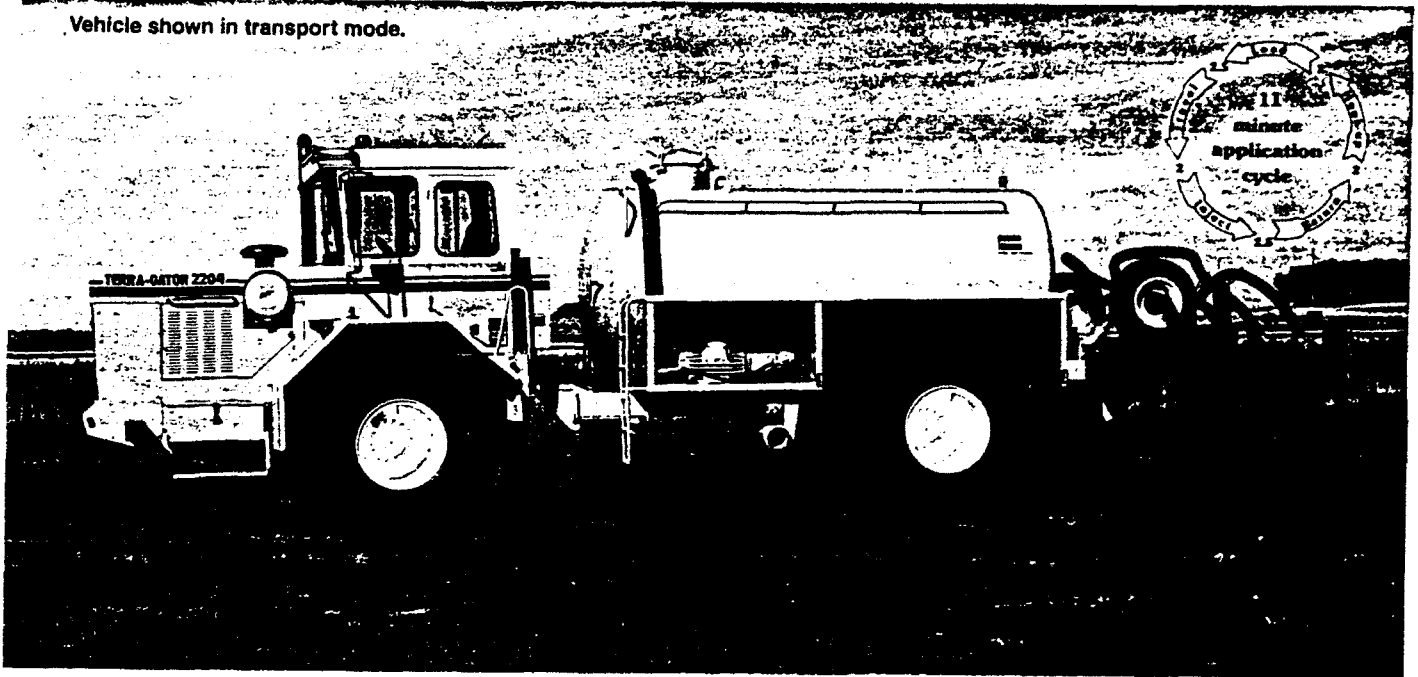

Figure 3. Terra-gator tank vehicle (Ag-Chem, 1992).

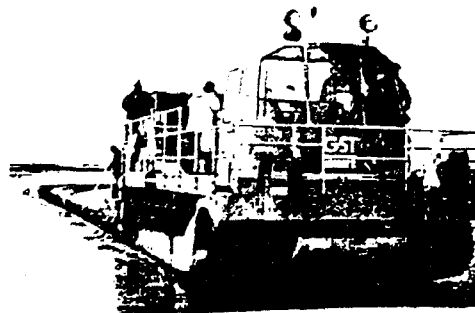

Figure 4. GST amphibious vehicle (Offshore, 1990).

Primarily used as agricultural sprayers and sludge applicators, the Terra-gator may be found only in limited areas. Other high floatation agricultural and construction vehicles exist and should be researched and reviewed for incorporation into the local contingency plan.

Mud flats and marshes can present special problems for delivery platforms. In Germany, GST Gesellschaft fur Systemtechnik mbH has introduced an 11 ton amphibious vehicle capable of deploying a 3 ton payload in low load bearing saturated areas. It is capable of travel on land, roads, and shallow water at speeds ranging from 5 to 12.5 mph. It exerts a pressure of only .05 bar (.75 psi) on such soils, thus its suitability for mud flats and marshes. Its large open bay permits the mounting of various oil spill equipment, including tank packages and spray booms for applying bioproduct. The vehicle, shown in Figure 4, was commissioned by the West German Ministry for Research and Technology.

The use of air cushioned vehicles (ACVs), also called Hovercraft, for use in oil spill responses is promising. Currently used by Navy and Marine amphibious forces, ACVs are capable of being operated over land and sea. Large fans blow air underneath the "skirted" boat creating a lift, or "hover". Rear mounted propellers provide the thrust necessary to move it up to speeds of 55 mph. They have large open bays capable of loads up to 50 tons. One theory of use is to mount the product filled tanks in the craft and inject the spray into the downdraft fans, depositing the aerated mixture onto the water surface, or mounting spray bars under the craft rather than extending them over the sides (Katz, 1989). ACVs have long operation times (8 to 10 hours) and could team with large ships that resupply the ACV with dispersant or bioproduct. The operation would be most effective in open oceans and close to shores. They could also be used to ferry the product and equipment in large quantities to remote areas, including marshes. A typical ACV is shown in Figure 5.

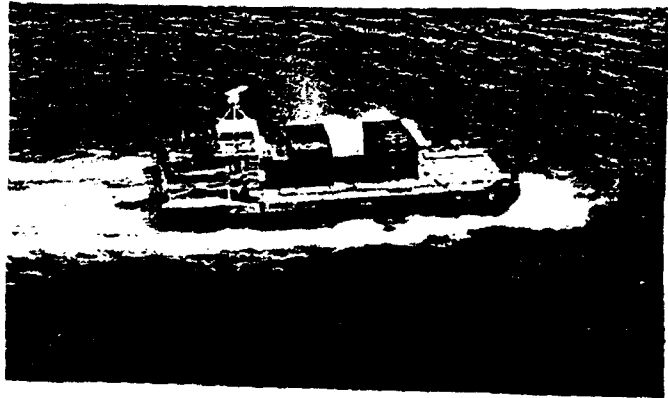
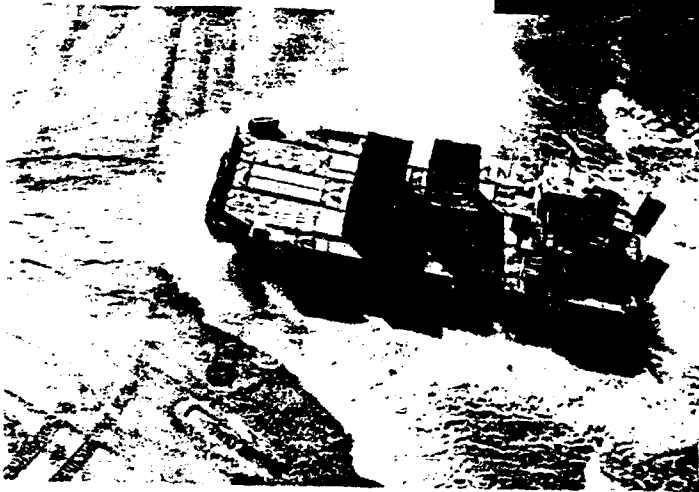
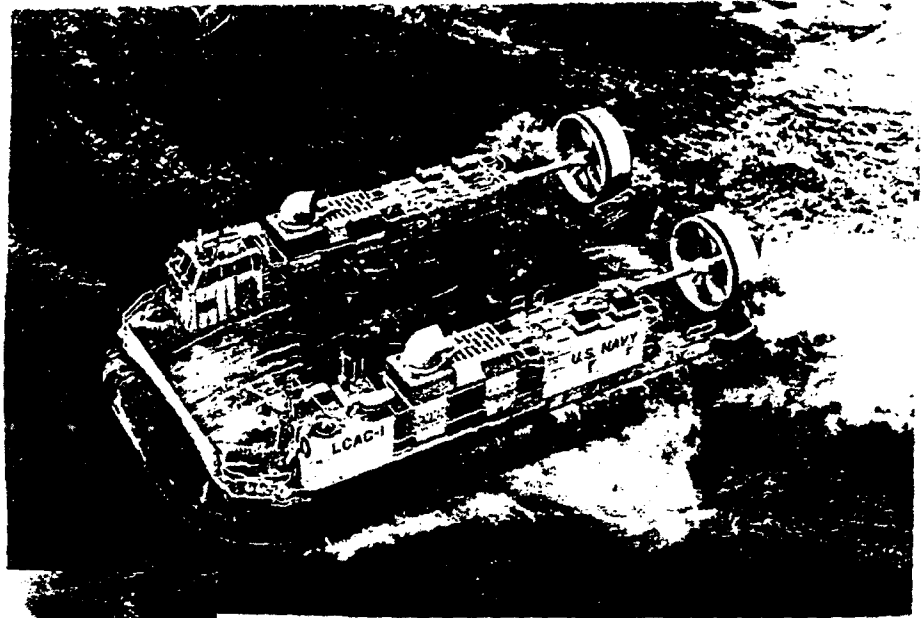

Figure 5. Air cushioned vehicles (ACV) (from Janes, 1988).

On a smaller scale, all terrain vehicles (ATVs) with their high floatation rubber tires, and fitted with small tanks and spray units, could be useful platforms, especially in hard to reach areas. These commercially produced three, four, six, and eight wheeled vehicles are suitable for remote sites, marshes, soft soil, and confined spaces where larger platforms are unable to maneuver. They would also be ideal for one man finishing operations. Used for recreation and hunting, the smaller three and four wheeled versions are common throughout the United States. The larger six and eight wheeled versions are not as common. ATVs are shown in Figure 6.

3.5.2 Equipment

The equipment used to apply bioremediation products is similar to that used in applying dispersants and is quite simple in design: a tank to supply the bioproduct, a pump to move the liquid mixture through hoses to the flowmeter, and a nozzle device to direct the spray.

Nozzles perform two functions: they form patterns to direct the spray and they adjust the size of the droplets. Nozzle attachments can produce streams or jets, such as fire nozzles, or they can form sprays to cover area, such as the nozzles on a spray boom or arm. Nozzles for spray should be sized to make droplets in the 600 to 800 micron range to minimize drift and evaporation losses (ITOPF, 1992).

Nozzles are readily available from a variety of sources and can be mounted to any system or delivery platform. Adjustable stream type nozzles are commonly used on firefighting equipment. Special eductor type nozzles are available that create a venturi that mixes concentrated bioproduct into the flow of the nozzle, Figure 7. These nozzles are common when using AFFF, or fire fighting foam, on pumper trucks and fire tugs.

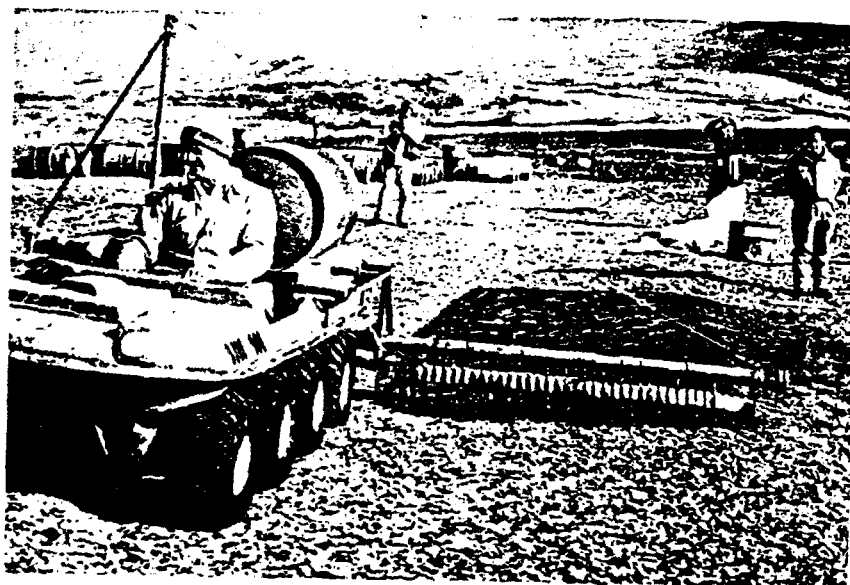

Figure 6. All terrain vehicle (ATV) (Owens, 1984).

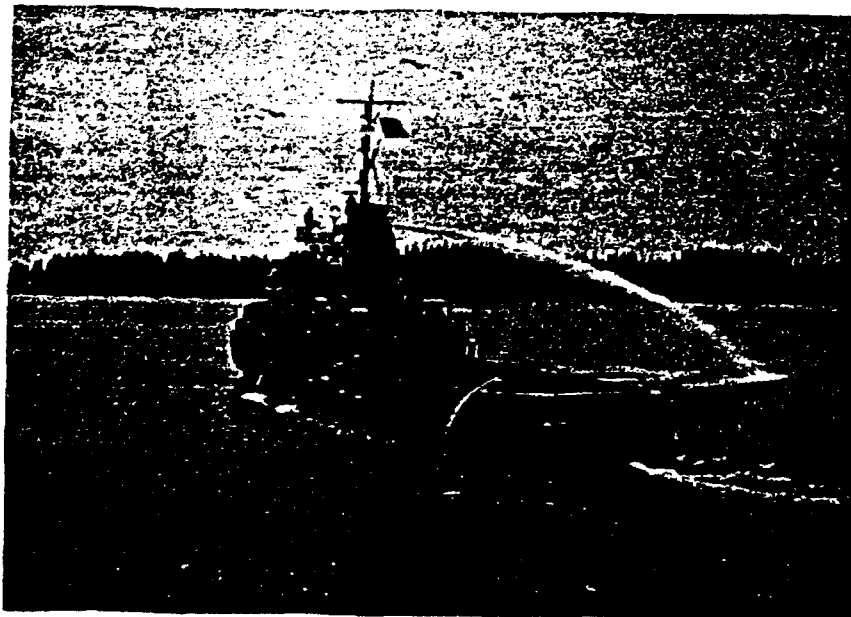

Figure 7. Eductor type nozzles (Kaufmann, 1984).

For aircraft, two types of nozzles predominate. Rotary atomizers consist of wind driven rotating gauze through which the product is pumped creating the required droplet size. These are commonly found on the small airplanes and helicopters, and can be mounted on booms. Large and small aircraft alike can use pressure nozzles. Product is forced through the outlets mounted on booms or arms, creating the desired droplet size. Atomizers are not used on large aircraft due to the numbers that would be required to produce the desired output. The two types of aircraft nozzles are shown in Appendix M.

Spray booms and arms allow for an efficient uniform rate of application of the bioproduct. Flowmeters are used to adjust the amount of product flowing to the nozzles. Spray booms with flowmeters should be calibrated prior to use to obtain optimal coverage rates as prescribed by the bioproduct manufacturer and to avoid wasting expensive product.

Spray booms can be mounted on any delivery platform. On aircraft, they are mounted above or below the main wings. On boats and vehicles, they are mounted fore, aft, or midship. Typical boom assemblies for aircraft and boats are shown in Appendix N.

Hoses extend the capability of a system to reach inaccessible areas. Hoses are used with nozzles and are common along shoreline activities and can be used to load the product. Flow to hoses can be provided by firepumps in most vessels of opportunity or firetugs, but output must be controlled by the pumping rate, bleeding off some of the water, or passing the flow through a flow meter to ensure proper dilution ratios as required. The use of hose systems to apply product is shown in Appendix O.

As previously described in Section 3.4, bioproducts can be applied in liquid concentrate, liquid mixtures, or in powder form. Products that are concentrated liquids or solids, that can be transported to the spill area, are advantageous to use in these forms because tank capacities are limited on the delivery

platforms. Products that can be mixed at the site allow for longer on scene residence times and reduces transit times required for resupply. Such is the advantage of using boats. Concentrate mixed into the firepump flow allows the vessel of opportunity to remain on station applying bioproduct because more of the bioproduct is on hand. Such is not the case with aircraft, since there are no means to carry concentrate and have access to natural dilution water while flying.

One possibility to overcome this problem was introduced by Katz, 1989. Large concentrate tanks could be mounted to a hydrofoil sled and pulled by a Sikorsky CH-53E Sea Dragon, currently in use by U.S. Navy mine sweeping units. They are capable of carrying payloads of 15 tons. The hydrofoil unit would draw the sea water from its foils, mix it with concentrate, then dispense it to the spray booms. Additional concentrate could be stored onboard or carried under the CH-53A and delivered to the empty sled via a resupply hose attached to the tow cable. The system could be operated at sea with large vessels resupplying the fuel and concentrate on the craft and sled, or providing fully loaded spare hydrofoils. The advantages of the system would be increased visibility, longer operations, and less agitation from the hydrofoil by not causing a "bow effect". Common with boats, the "bow effect" pushes the slick away from the sprayed product. The CH-53 pulling a mine sled is shown in Figure 8, but the same concept would be used for the hydrofoil dispersing system.

For products like WMI-2000, that require 2-4 hours of activation time, that cannot be diluted on site or during application, appropriate mixing vats will be required. The vats would be used to resupply the tanks in aircraft or the buckets for helicopter systems. Tanks would need to be located near both adequate natural water supplies and fields accessible to aircraft. One company that manufactures quick assembly, above ground, modular tanks is ModuTank, Inc. of New York. Leased or purchased, the company has sizes ranging from 2000 to 1 million



Figure 8. CH-53 Sea Dragon and mine sled (Janes, 1985).

gallons. Rental prices for the above-units range from \$786 to \$4316 per month. The company claims it can deliver and set up a 1 million gallon tank in 4.5 days, depending on location. These units could also be used for temporary storage of incoming skimmer waste, especially in remote areas where tankage is at a premium. A 1 million gallon system can be loaded and delivered on a single flat bed trailer and air freighted to any place in the world. Specifications and costs for various sizes of tanks are provided in Appendix P.

Other systems include specially designed packaged units used for aircraft and boats. The largest aircraft system, used by the Oil Spill Service Center of South Hampton, England, is called ADDSPACK, short for Aerial Dispersant Delivery System Package. This tank, pump, flowmeter, and spray boom system fits on a flat bed truck and into the rear of a C-130 Hercules, with no modifications. Traveling at 140 knots, 50 feet above the water surface, the system can spray .4 to 9.6 gallons per acre (74 acres per minute) or 5500 gallons of product through its 12.5 meter boom, as compared to only 3700 gallons from a DC-6. The ADDSPACK and typical systems for helicopters and boats are shown in Appendix Q.

Commercially produced agricultural sprayers mounted on trailers are ideal systems to use as applicators as well. The units consist of 100-500 gallon tanks mounted on trailers with high floatation rubber tires. Extended spray booms with nozzles apply the product over a large area. Modification of the nozzles would be required, but cost would be nominal. The units are common in the United States and are available through machinery suppliers. Back pack spray units, shown in Figure 9, are suitable for finishing operations or extremely confined areas where larger equipment is not practical.

Most systems are designed to deliver liquid product. Large scale systems designed to deliver dry powder product are not practical due to drifting. For smaller operations,

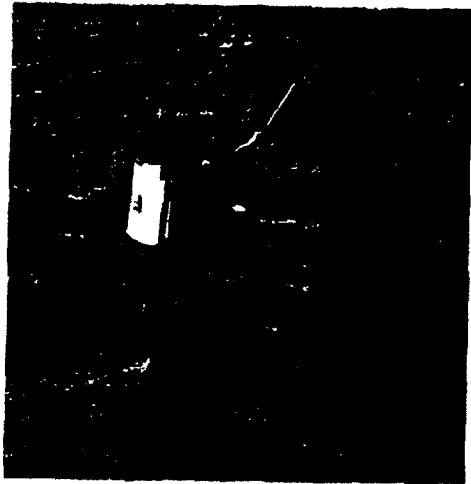

Figure 9. Back pack spray unit (Owens, 1984).

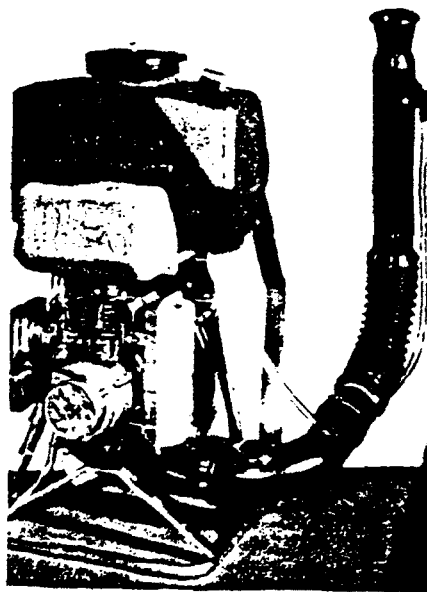

Figure 10. Blower unit (Katz, 1989).

specially modified leaf blowers, as shown in figure 10, are capable of applying powdered forms. Protection must be taken to avoid breathing the dust. No performance data was available on this unit.

For long term shoreline applications, it may be advantageous to design and operate sprinkler systems, similar to those used on household lawns, utilizing common garden hoses, PVC pipe, and sprinkler heads. This process was used on some of the dryer beaches during the Valdez experiments to ensure moisture was kept at optimum levels. A similar system can be used for spills on soil surfaces.

A more complex system is used to supply air and nutrients to subsurface soils and groundwater systems. The U.S. Air Force is currently bioremediating subsurface JP-4 sites using a combination of soil venting procedures and nutrient solution enhancement. Technical information on the buried vacuum, air, and nutrient solution pipes that make up the system is provided in Appendix R. The air is used for both vapor extraction of the volatile compounds and to supply air to the microbes. The same basic principle is used to remediate ground water systems, as well.

3.6 Summary

The technology that exists for bioremediation consists of the bioproducts added to the environment to stimulate degradation, the delivery platforms to transport the bioproduct to the site, and the equipment used to apply the mixture to the spill. Commercial bioproducts are relatively new and continued research and testing will determine their true, overall effectiveness in degrading oil and hydrocarbon spills. Nutrient enhancement products are the most common, followed by microbial seeding. Genetically engineered microbes (GEMs) are not used in bioremediating oil spills, but could play a role in the future.

It is likely that indigenous organisms capable of utilizing petroleum hydrocarbons will exist at most spill sites, thus reducing the need for microbial amendments.

The technology used to apply bioproducts is virtually the same as that used to apply dispersants. Systems consisting of tanks, pumps, nozzles, and spray booms are most common to the business. The delivery vehicles used to transport the product to the site to be applied by the system consists mainly of aircraft, boats, and land vehicles. Specialized equipment and platforms, such as the Terra-gator, ACVs and ATVs will be helpful for use at inaccessible areas, such as marshland. Most systems are widely available, though some are quite limited. Innovation will be the key to designing and manufacturing the technology to aid in the clean up and bioremediation of future spills. The matrix shown below, Table 3, was developed to match the delivery platform best suited for a given spill location in applying bioremediation products.

Table 3. Delivery platform application matrix.

	Large Aircraft	Small Aircraft	Helicopters / V22	Large Supply Vessel	Medium Boats	Landing Craft	Small Boats	Vacuum Trucks	Terra-gator	GST Mud Truck	Air Cushion Vehicle	All Terrain Vehicle	Blower Unit	Back Pack Unit	Sprinkler System	Bioventing
Open Ocean	x			x	x						x					
Near Shore	x	x	x	x	x	x					x					
Sand Beach	x 1	x 1	x			x	x	x	x	x	x	x	x	x	x	
Pebble Cobble Beach	x 1	x 1	x			x	x	x	x	x	x	x	x	x	x	
Boulder Shore			x			x	x	x					x	x		
Mud flats	x 1	x 1	x							x	x		x	x		
Marshes	x 1	x 1	x						x	x	x	x	x	x		
Tidal pools	x 1	x 1	x				x			x	x		x	x		

Note: 1) No obstacles higher than 10 meters for 1 mile.

Table 3. continued

	Large Aircraft	Small Aircraft	Helicopters/V22	Large Supply Vessel	Medium Boats	Landing Craft	Small Boats	Vacuum Trucks	Terragrator	GST Mud Truck	Air Cushion Vehicle	All Terrain Vehicle	Blower Unit	Back Pack Unit	Sprinkler System	Bioventing
Jetties			x		x	x	x	x					x	x		
Cliffs					x 2	x 2	x 2	x 2								
Pier/ Bulk-head					x 2	x 2	x 2	x 2						x		
Marinas					x 2	x 2	x 2	x 2								
Harbors		x 1	x		x	x										
Industrial Ports					x	x	x	x								
Estuaries		x 1	x		x	x										

Note: 1) No obstacles higher than 10 meters for 1 mile.
2) Use stream or jet nozzles.

Table 3. continued

	Large Aircraft	Small Aircraft	Helicopters/V22	Large Supply Vessel	Medium Boats	Landing Craft	Small Boats	Vacuum Trucks	Terragrator	GST Mud Truck	Air Cushion Vehicle	All Terrain Vehicle	Blower Unit	Backpack Unit	Sprinkler System	Bioventing
Rivers		x 1	x		x	x										
Creeks							x 2	x 2								
Lakes		x 1	x				x									
Ponds							x									
Surface Soils			x					x	x			x	x	x	x	
Subsurface Soils									x 3							x
Gound-water																x

Note: 1)No obstacles greater than 10 meters for 1 mile.
3)For soils less than 16 inches deep.

Section IV

Problems Associated with Bioremediation Technology

4.1 Introduction

When one takes the complex processes and environmental factors that affect biodegradation and combines them with the bioproduct and application technologies, problems are bound to arise that can decrease the effectiveness of the process. Each spill is unique in character, composition, location, size, etc. Therefore, the bioremediation treatment will be custom designed for each spill occurrence, as well.

This section will take a comprehensive look at problems and concerns a response manager could encounter during a spill response when using this technology. The intent is not to scare the reader nor discourage the use of bioremediation, but to stimulate the thought for advance planning so it may be incorporated into the local contingency plan. It could be used as a reference to assist planners in screening potential bioproducts for use at bioremediation sites. General problems associated with bioremediation, as a whole, will be discussed in Section 4.2, and more specific problems associated with bioproducts and application technology will be presented in Section 4.3.

4.2 General problems

As previously mentioned, bioremediation is not a magical cure all for hydrocarbon spills. First lines of defense to be deployed include skimming, burning, dispersing, stabilization, venting, and natural weathering processes to reduce the amount of petroleum product capable of fouling beaches, soils, and groundwater.

Should bioremediation be used at all? Its effectiveness, in combination with other defenses and processes, has been proven in oily land farming operations, tank cleaning, soil and groundwater remediation of fuel leaks, and recently, the beach finishing operations of the Valdez disaster. Yet, although it

was tried on the Mega Borg incident, inconclusive evidence exists to support its effectiveness in open ocean environments. Research and experimentation in actual spills should be continued to study what offshore situations bioremediation can be applied to, its effect in reducing the impact to shore lines if applied while the slick was still at sea, and if effective, when is the optimum time to apply it. Rates of degradation in open oceans were reported by the NRC, 1990, to be 100 - 960 mg/ cubic meter/ day. At these rates, there may be no significant reduction of oil by the time it hits the shore. Since dispersant application is time dependent, these bioproducts, if ineffective in degrading on open oceans, could be used as dispersants to break up the "chocolate mousse" formations that are resistant to dispersant applications. If the slick is far off shore and is not threatening the shore line, the same decision trees common to dispersant use can be applied to bioproduct use to determine if treatment is required. Again, all current data points to using other means to initially "treat" the slick (skimming, burning, etc.) before using bioremediation.

The degradation data that has been accumulating has also brought many critics. Response managers want immediate results to please the public, but the data suggests otherwise. Kelso, 1991, reported that extrapolations based on the monitoring data for the Valdez experiments indicate that bacteria could degrade 5 to 10 grams of hydrocarbons per kilogram of beach sediment per year. With oil amounts ranging from zero to 50 g/kg of sediment, the process could take 10 years to complete, assuming all the oil remains suitable for degradation. It may be slow, but what other alternatives exist?

Another similar problem is that the expectations of bioremediation have been so oversold, the inconclusiveness or failure of just one test, such as the Mega Borg trials, can produce skepticism of all bioremediation. Reluctance by response managers to use the technology could prevail,

especially if funds are tight. This would, in turn, reduce the amount of research and data that could become available for further studies. Austin, 1990, also explains that successful data may be lacking because companies that have completed full scale applications for clients are prohibited from discussing results because of proprietary rules. Thus, EPA can only base its recommendations on bench scale studies, and what happens in a beaker does not necessarily happen in the field.

Finally, lack of data diminishes the one big selling point of bioremediation: lower cleanup costs (Austin, 1990). OTA has revised estimates for incineration from \$600-\$800 down to \$300 per ton. In the case of the Valdez, bioremediation was only a small part of the clean up effort. The bioproducts were only applied to a small part of the 150 miles affected. The heavy concentrations of oil still had to be removed before bioremediation could begin. The additional costs should be figured into the total cost of clean up.

4.3. Specific problems

The charts shown below were developed to describe the many problems that can be encountered when using bioremediation technology. The charts are divided into Major Topics, Subtopics, and Problem. Major Topics include Spills, Spill Site, Bioproduct, Delivery Platforms, and Equipment. The Subtopic relates the Problem to the effect it has on Composition, Environment, Location, Logistics, Operations, and Planning. By knowing the Major Topic and selecting a Subtopic of interest or concern, one can determine the specific problems associated with that segment of bioremediation.

Major Topic: Spills

<u>Subtopic</u>	<u>Problem</u>
Composition	-type of crude or refined product
"	-concentration of product dispersed or not dispersed
"	-age of spilled product
"	-thickness of oil
"	-concentration of dissolved compounds under slick
"	-concentration of persistent compounds in slick
"	-concentration of C5-C9 compounds, if high, are toxic to microbes
"	-dispersibility of product
"	-product pour point is above ambient temperatures; bioproduct may not adhere to or penetrate slick
"	-what remains in product if it was burned
"	-other compounds that may inhibit degradation; heavy metals, halogenated compounds, etc.
"	-product is not in a state (physical, chemical) that makes it available to degradation
Location	-size and configuration of the slick
"	-slick will or will not hit land

Major Topic: Spill Site

<u>Subtopic</u>	<u>Problem</u>
Composition	-compounds are sorbed to rocks, sticks, grasses, mangroves, sand, sub soils, structures, piers, jetties, marinas, equipment, etc.
"	-site may not contain microbes capable of degradation; open ocean, groundwater, etc.
"	-may contain large quantities of organics
"	-may lack sufficient oxygen levels or the capability to recharge and aerate oxygen; groundwater, subsoil, marshes, etc.
"	-type of soil, moisture content, pH requirements
"	-temperature of soil or water at site
"	-seeding not required due to sufficient microbe levels
Environment	-weather and seasons dictate when bioremediation works; area has long cold winters and short cool summers or it is warm year round (Alaska vs. Persian Gulf)
Location	-location of spill
"	-site is remote; marsh, open ocean, etc.
"	-spill in subsoil, groundwater, floating on groundwater table, sinks in the ground water
"	-direction of the groundwater flow
"	-flooding conditions or excessive water can cause anaerobic conditions
"	-site not readily accessible by delivery platforms
"	-Area not subjected to wind and wave action to supply oxygen
"	-beached oil sinks into the subsoil

Major Topic: Bioproducts

<u>Subtopic</u>	<u>Problem</u>
Composition	-product is solid or liquid
"	-affected by sunlight; microbes die prior to application
"	-product increases or decreases amount of hydrocarbons attached to solids
"	-product floats, mixes, attaches to oil
"	-product requires no dilution
"	-product is nutrient enrichment, seed, or GEM
"	-product is soluble, nonsoluble, oleophilic, etc.
"	-product could float away if not applied directly to slick
"	-contains volatile active ingredients that can evaporate if applied from aircraft
"	-types of microbes contained in product
"	-microbes are predators or can be easily attacked themselves
"	-nutrient product sinks
"	-seed microbes are not found at spill site and become prey
"	-product acts as a dispersant and does not actually degrade oil
Environment	-product not proven effective in any situation
"	-product not proven in open water
"	-effect on fresh and weathered product, tarballs
"	-should sample test be performed prior to use
"	-do alternate tests on effectiveness exist
"	-is bioproduct toxic to humans, wildlife, marine life, mammals, birds, etc.
"	-does bioproduct bioaccumulate
"	-forms persistent or toxic compounds
"	-adverse effects on sensitive beaches, marshes, etc.
"	-acute and chronic affects on humans
"	-increase in rate of degradation over natural system vs. not applying bioproduct
"	-produces air pollution
"	-tolerance concentration of C5-C9 compounds for seed products
"	-seed product sinks or disperses oil, not degrading it
"	-nutrient product consumed by non degrading microbes

Major Topic: Bioproducts

<u>Subtopic</u>	<u>Problem</u>
Environment	-nutrients can cause eutrophication or a'gae blooms
"	-oxygen uptake so fast, recharge not possible in time to sustain growth; tidal areas, marshes, etc.
"	-not effective after dispersant use due to toxic level of dispersant
"	-overdosing of nutrient products causes reverse pollution of water environments
"	-GEMs could outlive the oil and consume other organisms like beasts out of control
"	-because some compounds are more easily degraded than others, inoculums may only contain microbes that degrade the easy compounds, and will build resistances to degrading other persistent compounds
Logistics	-application requires special protective equipment to protect user
"	-product must be activated prior to use, requiring ample water supplies and tanks for mixing
"	-Inert bran and carriers must be settled and filtered if solution is to be used in pressure nozzles
"	-product is too expensive for the level of its performance
"	-must be selected based on available delivery systems and equipment
"	-must be selected due to specifics of the spill site and location, ie adhesion to oily surfaces, migration into porous soils, etc.
"	-selection based on number of applications required to be effective
"	-product not selected due to limited range of compounds it is capable of degrading
"	-product is not available in sufficient quantities

Major Topic: Bioproducts

<u>Subtopic</u>	<u>Problem</u>
Operations	-difference between expected and actual performance
"	-effects on performance if used after dispersants
"	-requires dilution what type of water is suitable, natural or tap
"	-rates of application and coverages
"	-depth of soil and water columns product is effective
"	-oxygen requirements
"	-is product aerobic or anaerobic
"	-seed product does not contain nutrients; must be supplemented; not suitable for open ocean application
"	-product can be used at any pH range
"	-product suitable for saline environments
"	-product doesn't work in wide range of temperatures
"	-product is site specific or can be used in any soil or water environment
"	-product requires multiple applications
"	-can be used on mammals and birds
"	-after application, product must be agitated or mixed to be effective; not suitable for aerial application
"	-product does not penetrate slick and remains on surface
"	-seed products and microbes cannot withstand pressures in the nozzle, deep oceans, groundwater, affecting osmotic abilities
"	-product becomes too viscous at low temperatures; clogs nozzle equipment
"	-solidifies in cold temperatures
"	-product has short shelf life; poor performance if acquired near expiration date
"	-seed product may take long time to become acclimated to new environment
"	-seed product was developed for soil cultures, not effective in water
"	-degradation from combination seed /nutrient products may be due to indigenous microbes utilizing the nutrient, the microbe, or both as a source; the seed has no effect
"	-product merely washes the oil, no degradation takes place

Major Topic: Bioproduct

<u>Sample</u>	<u>Problem</u>
Operations	-granular fertilizers sink the oil
"	-non-oleophilic products are easily washed from shoreline and require constant reapplication
Planning	-can be used on any type of hydrocarbon or is contamination specific
"	-is capable of degrading all constituents in contaminant
"	-speed at which it will degrade or mineralize contaminant; when does degradation begin; how much will be degraded with time
"	-product takes days, weeks, months, years to degrade to small levels. not suitable for offshore applications
"	-product has not been field tested nor any performance data exists
"	-how is effectiveness measured
"	-maximum concentration product is applied
"	-product is not licensed or approved by the EPA for spills

Major Topic: Delivery Platforms

Airplanes

Subtopic

Problems

- Logistics -availability
" -sufficient quantities
" -capacity to hold tanks or packaged units
" -qualified trained personnel
" -difficult to track area just sprayed
- Operations -range
" -tank capacity
" -limited to open unconfined spaces
" -optimum altitude: 50 feet for airplanes
30 feet for helicopters
" -fast speeds distort spray: 150 mph or less
for bioproducts with viscosities 60 cSt
or greater, 115 mph or less for
bioproducts with viscosities of 60cSt or
less (NRC, 1989)
" -shape of airplane can distort spray pattern
" -requires airport close to site with
appropriate fuel and maintenance
facilities
" -requires routine maintenance schedules
that could disrupt application schedules
" -can't fly in bad weather
" -wind causes drift of bioproduct off
target; effective spray width ranges from
1.2 to 1.5 times the boom width (NRC,1990)
" -wind causes evaporation of bioproduct
" -small planes not effective for offshore
use
- Planning -requires low level flight approval

Helicopters

- Logistics -availability
" -capability to sling buckets
" -limited capacity
" -trained personnel
- Operations -short range over water
" -downdraft distorts spray pattern for
mounted spray systems
" -can't maneuver near trees, power lines, etc.
- Planning -need approval for low level flight and to
carry sling loads across highways

Major Topic: Delivery Platforms

Boats

<u>Subtopic</u>	<u>Problem</u>
Logistics	-availability
"	-capacity and tankage available
"	-stability
Operations	-boats are slow
"	-bow waves can push oil beyond spray booms
"	-firepumps on board provide too much capacity; excess water needs to be bled off to conform to proper dilution rates
"	-poor visibility in sighting slick; requires spotter aircraft
"	-short booms required due to pitch and roll
"	-inability to hold a straight course
"	-not operable in high sea states
"	-limited spray area per areal time
"	-limited ability to track sprayed area
"	-access to limited open areas

Land Vehicles

Environment	-can damage sensitive environments; rutting of soft soils, trampling vegetation, etc.
"	-tires and tracks can force contamination deeper
Logistics	-availability
"	-capacity
Operations	-access to the site
"	-range
Planning	-approval to use in sensitive areas, endangered species habitats, like sea turtle nesting areas, etc.

Major Topic: Equipment

<u>Subtopic</u>	<u>Problem</u>
Environment	-pressure in nozzle system could affect osmotic capabilities of microbes, rendering them useless; average pressure in a spray system is less than 3 atmospheres
"	-tanks used with concentrated dispersants should be rinsed prior to bioproduct use to avoid killing microbes
Logistics	-equipment or systems available
"	-special protective equipment required for toxic bioproducts
"	-packaged units not capable of being deployed in or on delivery platforms
"	-units cannot supply sufficient capacity and flow rates
Operations	-nozzle orifice too small to produce correct droplet size
"	-orifice too big; product wasted
"	-nozzles clogged by seeding bran or carrier
"	-viscous bioproduct gels pressure nozzles or rotary atomizers in aerial applicators
"	-nozzle shear not sufficient to cause spray of viscous bioproducts
"	-nozzle quantity not sufficient to produce required flow rate
"	-flow rate insufficient from flow meter
"	-equipment produces poor accuracy of delivery ; accuracy rates of 45 to 90% can be expected
"	-firepumps, pumps, flow meters, etc. require calibration to avoid wasting product
"	-nozzles do not form fan pattern decreasing effective spray
"	-nozzles and rotary atomizers require maintenance of internal parts
"	-blowouts possible in bioventing systems
"	-underground fires possible in bioventing systems (NRC,1989)
"	-spray booms subject to freezing, especially in aerial systems
"	-equipment breaks down and requires maintenance

Conclusions

Bioremediation is a promising technology in solving the problems of hydrocarbon spill clean ups, but has its limitations. A wide variety of environmental factors, including oxygen levels, nutrient requirements, microorganisms, moisture content, etc., can affect the rate of degradation of the contaminant.

The compounds that make up hydrocarbon products are vast in number and have a wide array of specific characteristics. While some are easy to degrade, some can be toxic and persistent in the environment. Thus, a wide variety of microorganisms must be relied upon to fully degrade and mineralize these compounds.

The technology that exists for bioremediation consists of bioproducts to stimulate microbial growth or add to their populations, equipment for application purposes including nozzles, spray booms, pumps, and packaged units, and delivery platforms to transport bioproduct application systems to the sites. The effectiveness of the technology will depend on its availability, bioproduct performance, and other site specific characteristics.

Bioremediation is not a magical silver bullet and problems associated with the technology exist. Understanding the basic principles, contaminant composition, rate and degree of degradation, bioproduct performance and capabilities, and the types of delivery platforms and equipment used to apply the bioproduct is the key in helping response planners and managers determine the feasibility of bioremediation as a potential clean up technology.

REFERENCES

- Ag-Chem Equipment Company, Inc., "The Professional Approach to Waste Application". Product literature, Minnetonka, Minnesota, 1992.
- Atlas, R.M., "Microbial Hydrocarbon Degradation - Bioremediation of Oil Spills". Applied Microbiology, 1990.
- Austin, T., "Bio Bonanza". Civil Engineering, April, 1990.
- Barnhart, M.J., et al., "Pilot Bioremediation Tells All About Petroleum Contaminated Soil". Pollution Engineering, October, 1989.
- Beckman, J., "Moving in for the Spill". The Oilman, September, 1991.
- Clark, R.C., and MacLeod, W.D., "Effects of Petroleum on Arctic Marine Environments". D.C. Malins Academic Press, 1977.
- Clewell, H.J., "The Effects of Fuel Composition On Ground Fuel from Aircraft Fuel Jettisoning". Report to Engr. Service Center, Tyndall AFB, FL, 1981
- Crain, O.L., "A Multifaceted Approach to Applying Dispersants". American Society for Test Materials, Philadelphia, 1984.
- Cunningham, D., "The Biodegradation of Crude Oil in the Marine Environment". Masters of Science Thesis, Department of Civil Engineering, Texas A&M University, December, 1990.
- Editor, "Amphibious Vehicle Combats Oil Spills". Offshore, July, 1990.
- Editor, "Norwegian Association Directs Response to Major Oil Spills". Offshore, February, 1991.
- Editor, "Gulf Slick a Free Lunch for Bacteria". Science, vol 249, 13 July, 1990.
- Editor, "Research Efforts Advance Oil Spill Response Effectiveness". Offshore, January, 1991.
- Editor, "Alaska Study Shows Bioremediation Should Be Combined With Other Methods". Offshore, July, 1991.

- Elf Aquitaine, "Inipol EAP 22 Biodegradation Accelerating Agent". Product literature, Paris, France, 1992.
- Floodgate, G.D., "The Fate of Petroleum in Marine Environments". Petroleum Microbiology, R.M. Atlas (ed.), New York, New York, 1984.
- Germerroth, R.M., et al., "Jet Fuel From the Ground Up". Civil Engineering, February, 1987.
- Graham, J., "Oil Eating Microbes Control Oil Slicks". Water Environment and Technology, April, 1992.
- Green, J., et al., "The Fate and Effects of Oil in Freshwater". Elsevier Science Publishing Co., Inc., New York, 1990.
- ITOPF: The International Tanker Owners Pollution Federation, LTD., "Aerial Application of Oil Spill Dispersants". Technical Paper, Number 3, 1992.
- ITOPF, "Use of Oil Spill Dispersants". Technical Paper, Number 4, 1992.
- Jamison, V.W, et. al, "Biodegradation of High Octane Gasoline in Groundwater". Developments in Industrial Microbiology, 16:305-312, 1975.
- Janes, "All the Worlds Aircraft". Janes Publishing Co., Ltd., New York, 1985.
- Janes, "Fighting Ships". Janes Publishing Co., Ltd., New York, 1987.
- Janes, "High Speed Marine Craft and Air Cushion Vehicles". Janes Publishing Co., Ltd., New York, 1988.
- Katz, W.B., "A New Pair of Eyes II. Looking at Dispersants from a Different Point of View". ASTM, Philadelphia, 1989.
- Kaufmann, S., "Treatment of Oil Spill Fire Hazards with Chemical Dispersants". ASTM, Philadelphia, 1984.
- Leahy, J.G., and Colwell, R.R., "Microbial Degradation of Hydrocarbons in the Environment". Microbiological Reviews, pg. 305-315, September, 1990

- National Technical Information Service (NTIS), "The Microbial Degradation of Oil Pollutants". Louisiana State University, 1973.
- National Research Council, "Using Oil Spill Dispersants on the Sea". National Academy of Sciences, 1989.
- Nichols, A.B., "Bioremediation: Potentials and Pitfalls". Water Env. and Tech., February, 1992.
- Okpokwasili, G.C., et al., "Effect of Salinity on Biodegradation of Oil Spill Dispersants". Waste Management, vol. 10, 1990.
- Onstad, L.A., et al., "Design and Evaluation of a Large Boat Mounted Dispersant Spraying System". ASTM, Philadelphia, 1989.
- Oppenheimer Environmental company, "The Oppenheimer Formula". Product Literature, Austin, TX, 1992.
- Owens, E.H. et al., "Experimental Use of Dispersants for Spill Countermeasures on Arctic Beaches". ATSM, Philadelphia, 1984.
- Parker, C.A., "The Effect of Some Chemical and Biological Factors on the Degradation of Crude Oil at Sea". Admiralty Materials Laboratory, England, 1991.
- Pritchard, H.P., "EPA's Alaska Oil Spill Bioremediation Project". Env. Sci. Tech., vol 25, No 3, 1991.
- Roberts, E.R., "Bioremediation of Petroleum Contaminated Sites". CRC Press, Inc., Boca Raton, FL, 1992.
- Robinson, K.G., et al., "Bioremediation Removes Gasoline Residues". Pollution Engineering, August, 1991.
- Samouce, W.A., "Maritime Oil Spills - A Tiltrotor Solution". Bell/Textron Helicopter, May, 1990.
- Sky Blue Chems, "Oil Spill Eater". Product literature, Dallas, TX, 1992.
- Smith, J.H, et al., "Report ESL-TR-81-54". Engr. Service Center, Tyndall AFB, FL, 1981.
- Spain, J.C., "Biotech Research: A Proactive Approach". The Military Engineer, Volume 84, August, 1992.

Texas General Land Office, "Mega Borg Oil Spill, An Open Water Bioremediation Test". Technical Report, 12 July, 1990.

Tissot, B.P., and Welte, D.H., "Petroleum Formation and Occurances". Springer Verlag, 1984.

U. S. Air Force Engineering and Services Center, "Enhanced In-situ Biodegradation of Petroleum Hydrocarbons Through Soil Venting". Technical RDV-17, Tyndall AFB, FL, July, 1991.

U.S. Congress Office of Technology Assessment, "Bioremediation for Marine Oil Spills - Background Paper". U.S. Government Printing Office, May, 1991.

Waste Microbes, Inc., "Bioremedial Technologies". Product literature, Houston, TX, 1992.

Westermeyer, W.E., "Oil Spill Response Capabilities in the United States". Env. Sci. Tech., vol 25, No 2, 1991.

APPENDICES

<u>Appendix</u>	<u>Title</u>	<u>Page</u>
A	Crude oil classification.	74
A.1	Composition of fuel oil, gasoline JP-4, and JP-5.	75
B	Solubilities of petroleum constituents.	78
C	Oil degrading microbes for specific contaminants.	79
D	Degradation rates at certain remediation sites.	84
E	Medina product performance.	87
F	Inipol EAP 22 product performance.	88
G	WMI-2000 product uses.	89
H	Oppenheimer product performance.	90
I	Rotary wing aircraft for aerial application.	91
J	Fixed wing aircraft for aerial application.	93
K	Vessels of opportunity.	95
L	Terra-gator models and specifications	96
M	Aircraft nozzles - pressure and rotary	97
N	Typical Boom assemblies.	98
O	Typical hose systems.	100
P	Modutank, Inc. specifications.	101
Q	Typical packaged units.	102
R	U.S. Air Force technical data on bioventing.	103

Appendix A - Crude oil classification (from Green, 1990).

Classification of crude oils. (From Tissot and Welte, 1984)

<i>Concentration in crude oil >210 C</i>				
<i>S = saturates AA = aromatics + resins + asphaltenes</i>	<i>P = paraffins N = naphthenes</i>	<i>Crude oil type</i>	<i>Sulphur content in crude oil (approximate)</i>	<i>Number of samples per class (total = 541)</i>
	<i>P > N and P > 40%</i>	Paraffinic		100
<i>S > 50%</i>	<i>P > 40% and N > 40%</i> <i>N > P and N > 40%</i>	Paraffinic-naphthenic	<1%	217
<i>AA < 50%</i>		Naphthenic		21
	<i>P > 10%</i>	Aromatic intermediate		126
<i>S < 50%</i>	<i>P < 10%</i>	<i>N < 25%</i> Aromatic asphaltic	>1%	41
<i>AA > 50%</i>	<i>P < 10%</i>	<i>N > 25%</i> Aromatic naphthenic	generally S < 1%	36

Appendix A.1 - Composition of fuel oil and JP-4 (from Roberts, 1992).

Composition of Diesel Fuel #2 (Clewell, 1981)

Component	Concentration (% Volume)	Component	Concentration (% Volume)
C ₁₀ paraffins	0.9	C ₁₅ paraffins	7.4
C ₁₀ cycloparaffins	0.6	C ₁₅ cycloparaffins	5.5
C ₁₀ aromatics	0.4	C ₁₅ aromatics	3.2
C ₁₁ paraffins	2.3	C ₁₆ paraffins	5.8
C ₁₁ cycloparaffins	1.7	C ₁₆ cycloparaffins	4.4
C ₁₁ aromatics	1.0	C ₁₆ aromatics	2.5
C ₁₂ paraffins	3.8	C ₁₇ paraffins	5.5
C ₁₂ cycloparaffins	2.8	C ₁₇ cycloparaffins	4.1
C ₁₂ aromatics	1.6	C ₁₇ aromatics	2.4
C ₁₃ paraffins	6.4	C ₁₈ paraffins	4.3
C ₁₃ cycloparaffins	4.8	C ₁₈ cycloparaffins	3.2
C ₁₃ aromatics	2.8	C ₁₈ aromatics	1.8
C ₁₄ paraffins	8.8	C ₁₉ paraffins	0.7
C ₁₄ cycloparaffins	6.6	C ₁₉ cycloparaffins	0.6
C ₁₄ aromatics	3.8	C ₁₉ aromatics	0.3

Composition of JP-4 (Clewell, 1981)

Component	Concentration (% Volume)	Component	Concentration (% Volume)
C ₅ hydrocarbons	3.9	Napthalene	0.2
C ₆ paraffins	8.1	C ₁₁ paraffins	4.8
C ₆ cycloparaffins	2.1	C ₁₁ cycloparaffins	2.5
Benzene	0.3	Dicycloparaffins	3.4
C ₇ paraffins	9.4	C ₁₁ aromatics	1.1
C ₇ cycloparaffins	7.1	C ₁₁ naphthalenes	0.2
Toluene	0.7	C ₁₂ paraffins	2.8
C ₈ paraffins	10.1	C ₁₂ cycloparaffins	1.2
C ₈ cycloparaffins	7.4	C ₁₂ aromatics	0.5
C ₈ aromatics	1.6	C ₁₂ naphthalenes	0.2
C ₉ paraffins	9.1	C ₁₃ paraffins	1.1
C ₉ cycloparaffins	4.3	C ₁₃ cycloparaffins	0.4
C ₉ aromatics	2.4	C ₁₃ aromatics	0.1
C ₁₀ paraffins	7.3	C ₁₄ hydrocarbons	0.2
C ₁₀ cycloparaffins	3.7	C ₁₅ hydrocarbons	0.1
C ₁₀ aromatics	1.8	Tricycloparaffins	1.8
		Residual hydrocarbons	0.1

Appendix A.1 - Components of Gasoline (from Roberts, 1992).

Components of Gasoline (Jamison, Raymond, and Hudson, 1976)

Component	Component
n-Propane	2,5-Dimethylhexane
n-Butane	2,4-Dimethylhexane
n-Pentane	2,3-Dimethylhexane
n-Hexane	3,4-Dimethylhexane
n-Heptane	2,2-Dimethylhexane
n-Octane	2,2-Dimethylheptane
n-cis-Butene-2	1,1-Dimethylcyclopentane
n-Pentane-2	1,2- and 1,3-Dimethylcyclopentane
2,3-Dimethylbutene-1	1,3- and 1,4-Dimethylcyclohexane
Olefins C ₄	1,2-Dimethylcyclohexane
Olefins C ₅	2,2,3-Trimethylbutane
Olefins C ₆	2,2,4-Trimethylpentane
Isobutane	2,2,3-Trimethylpentane
Cyclopentane	2,3,4-Trimethylpentane
Cyclohexane	2,3,3-Trimethylpentane
Methylcyclopentane	2,2,5-Trimethylpentane
Methylcyclohexane	1,2,4-Trimethylcyclopentane
2-Methylbutane	Ethylpentane
2-Methylpentane	Ethylcyclopentane
3-Methylpentane	Ethylcyclohexane
2-Methylhexane	Benzene
3-Methylhexane	Ethylbenzene
2-Methylheptane	Toluene
3-Methylheptane	o-Xylene
4-Methylheptane	m-Xylene
2,2-Dimethylbutane	p-Xylene
2,3-Dimethylbutane	
2,2-Dimethylpentane	
2,4-Dimethylpentane	
3,3-Dimethylpentane	
2,3-Dimethylpentane	

Appendix A.1 - Composition of JP-5 (from Roberts, 1992).

Major Components of JP-5 (Smith, Harper, and Jaber, 1981)

Fuel Component	Concentration (Weight Percent)
n-Octane	0.12
1,3,5-Trimethylcyclohexane	0.09
1,1,3-Trimethylcyclohexane	0.05
m-Xylene	0.13
3-Methyloctane	0.07
2,4,6-Trimethylheptane	0.09
o-Xylene	0.09
n-Nonane	0.3
1,2,4-Trimethylbenzene	0.37
n-Decane	1.79
n-Butylcyclohexane	0.90
1,3-Diethylbenzene	0.61
1,4-Diethylbenzene	0.77
4-Methyldecane	0.78
2-Methyldecane	0.61
1-Ethylpropylbenzene	1.16
n-Undecane	3.95
2,6-Dimethyldecane	0.72
1,2,3,4-Tetramethylbenzene	1.48
Naphthalene	0.57
2-Methylundecane	1.39
n-Dodecane	3.94
2,6-Dimethylundecane	2.00
1,2,4-Triethylbenzene	0.72
2-Methylnaphthalene	0.90
1-Methylnaphthalene	1.44
1-Tridecane	0.45
Phenylcyclohexane	0.82
n-Tridecane	3.45
1-t-Butyl-3,4,5-trimethylbenzene	0.24
n-Heptylcyclohexane	0.99
n-Heptylbenzene	0.27
Biphenyl	0.70
1-Ethynaphthalene	0.32
2,6-Dimethylnaphthalene	1.12
n-Tetradecane	2.72
2,3-Dimethylnaphthalene	0.46
n-Octylbenzene	0.78
n-Pentadecane	1.67
n-Hexadecane	1.07
n-Heptadecane	0.12

Appendix B - Solubilities of petroleum constituents (from Green, 1990).

(From Clark & MacLeod, 1977)

<i>Compound</i>	<i>Carbon number</i>	<i>Solubility^a (ppm)</i>
<i>Paraffins</i>		
Methane	1	24
Ethane	2	60
Propane	3	62
<i>n</i> -Butane	4	61
<i>n</i> -Pentane	5	39
<i>n</i> -Hexane	6	9.5
2-Methylpentane	6	13.8
3-Methylpentane	6	12.8
2,2-Dimethylbutane	6	18.4
<i>n</i> -Heptane	7	2.9
<i>n</i> -Octane	8	0.66
<i>n</i> -Nonane	9	0.220
<i>n</i> -Decane	10	0.052
<i>n</i> -Undecane	11	0.0041
<i>n</i> -Dodecane	12	0.0037
		0.0029 (SW)
<i>n</i> -Tetradecane	14	0.0022
		0.0017 (SW)
<i>n</i> -Hexadecane	16	0.0009
		0.0004 (SW)
<i>n</i> -Octadecane	18	0.0021
		0.0008 (SW)
<i>n</i> -Eicosane	20	0.0019
		0.0008 (SW)-
<i>n</i> -Hexacosane	26	0.0017
		0.0001 (SW)
<i>n</i> -Triacontane	30	0.002
<i>n</i> -Heptacontane	37	10 ^{-8b}
<i>Cycloparaffins</i>		
Cyclopentane	5	156
Cyclohexane	6	55
Cycloheptane	7	30
Cyclooctane	8	7.9
<i>Aromatics</i>		
Benzene	6	1780
Toluene	7	515
<i>o</i> -Xylene	8	175
Ethylbenzene	8	152
1,2,4-Trimethylbenzene	9	57
iso-Propylbenzene	9	50
Naphthalene	10	31.3
		22.0 (SW)
1-Methylnaphthalene	11	25.8
2-Methylnaphthalene	11	24.6
2-Ethylnaphthalene	12	8.00
1,5-Dimethylnaphthalene	12	2.74
2,3-Dimethylnaphthalene	12	1.99
2,6-Dimethylnaphthalene	12	1.30
Biphenyl	12	7.45
		4.76 (SW)
Acenaphthene	13	3.47
Phenanthrene	14	1.07
		0.71 (SW)
Anthracene	14	0.075
Chrysene	18	0.002

^a In distilled water, except where noted by (SW), indicating filtered seawater, usually corrected to a salinity of 35‰ (parts per thousand). ppm = parts per million—micrograms per gram

^b Extrapolated

Appendix C - Oil degrading microbes for specific contaminants
(from Roberts, 1992).

Fuel Components/Hydrocarbons and Microorganisms Capable of
Biodegrading/Biotransforming Them

Fuel Component/ Hydrocarbon	Microorganisms
Acrylonitrile	Mixed culture of yeast, mold, protozoa, bacteria; activated sludge ^a
Alkanes	<i>Pseudomonas</i> ^p , <i>Arthrobacter</i> , <i>Acinetobacter</i> , yeasts, <i>Penicillium</i> sp., <i>Cunninghamella blakesleeana</i> , <i>Absidioglauca</i> , <i>Mucor</i> sp. ^f
<i>n</i> -Alkanes (C ₁ to C ₄) gaseous	<i>Mycobacterium ketoglutamicum</i> ^f
<i>n</i> -Alkanes (C ₃ to C ₁₆)	<i>Mycobacterium rhodochrous</i> ^g
<i>n</i> -Alkanes (C ₈ to C ₁₆)	<i>Mycobacterium fortuitum</i> , <i>M. smegmatis</i> ^g
<i>n</i> -Alkanes (C ₁₂ to C ₁₆)	<i>Mycobacterium marinum</i> , <i>M. tuberculosis</i> ^g <i>Corynebacterium</i> ^f
<i>n</i> -Alkanes (C ₅ to C ₁₆)	(<i>Arthrobacter</i> , <i>Acinetobacter</i> , <i>Pseudomonas putida</i> , yeasts) ^f
<i>n</i> -Alkanes (C ₁₀ to C ₁₄)	<i>Corynebacterium</i> ^g
<i>n</i> -Alkanes (C ₈ to C ₂₀)	<i>Acinetobacter</i> ^h
<i>n</i> -Alkanes (C ₁₁ to C ₁₉)	<i>Prototheca zopfii</i> ⁱ , <i>Pseudomonas</i> spp. ^{k,m}
Alkanes (straight chain)	<i>Pseudomonas putida</i> ^f
Alkenes (C ₆ to C ₁₂)	<i>Pseudomonas oleovorans</i> ^{ab}
Anthracene	Stream bacteria ^a , (<i>Flavobacterium</i> , <i>Beijerinckiasp.</i> , <i>Cunninghamella elegans</i>) ^h (<i>Pseudomonas/Alcaligenes</i> sp., <i>Acinetobacter</i> sp., <i>Arthrobacter</i> sp.) ^k
Aromatics	<i>Pseudomonas</i> sp. ^f
Benzene	<i>Pseudomonasputida</i> ^{a,h,aa} , sewage sludge ^a , stabilization pond microbes ^a , <i>P. rhodochrous</i> ^f , <i>P. aeruginosa</i> ^f , methanogens ^{f,3} , anaerobes ^f , <i>Acinetobacter</i> sp. ^{aa} , <i>Methylosinus trichosporium</i> OB3b ^{ag} , <i>Nocardia</i> sp. ^{ah} ,
Benzo(a)anthracene	<i>Beijerinckia</i> sp. ^{c,g} , <i>Cunninghamella elegans</i> ^{a,u} <i>Pseudomonas</i> sp. ^f
Benzo(a)pyrene	(<i>Candidalipolytica</i> , <i>C. tropicalis</i> , <i>C. guilliermondii</i> , <i>C. maltosa</i> , <i>Debaryomyces hansenii</i>) ^a , <i>Bacillus megaterium</i> ^b <i>Beijerinckia</i> sp. ^{c,g} , <i>Cunninghamella elegans</i> ^{a,u,ag} , <i>Pseudomonas</i> sp. ^a , <i>Neurospora crassa</i> ^a , <i>Saccharomyces cerevisiae</i> ^a

Appendix C - continued.

Fuel Component/ Hydrocarbon	Microorganisms
Biphenyl	(<i>Candida lipolytica</i> , <i>C. tropicalis</i> , <i>C. Guilliermondii</i> , <i>C. maltosa</i> , <i>Debaryomyces hansenii</i>) ^a , (<i>Beijerinckia</i> B8/36, <i>Oscillatoria</i> sp., <i>Pseudomonas putida</i>) ^{a,aa} , <i>Cunninghamella elegans</i> ^h , (<i>Moraxella</i> sp., <i>Pseudomonas</i> sp., <i>Flavobacterium</i> sp.) ^{ad} , <i>Beijerinckia</i> sp. ^{ae} , <i>Oscillatoria</i> sp. ^{ap}
<i>n</i> -Butane	<i>Mycobacterium smegmatis</i> , <i>Pseudobacterium</i> <i>subiuteum</i> , <i>Pseudomonas fluorescens</i> , <i>Actinomyces candidus</i> ^q , (<i>Arthrobacter</i> , <i>Brevibacterium</i>) ^f
Chlorobenzene	<i>Pseudomonas putida</i> ^{aa}
Cresols	<i>Methylosinus trichosporium</i> OB3b ^{ag}
<i>p</i> -Cresol	<i>Pseudomonas</i> sp. ^{ai}
Cyclohexane	<i>Xanthobacter</i> sp., <i>Nocardia</i> sp. ^h
Cyclohexanol	<i>Xanthobacter autotrophicus</i> ^{ak} , (<i>Acinetobacter</i> , <i>Nocardia globerula</i>) ^h
Cyclohexanone	<i>Xanthobacter autotrophicus</i> ^{ak}
Decane	<i>Corynebacterium</i> ^f
Dibenzanthracene	Activated sludge ^g
Dodecane	(<i>Arthrobacter</i> , <i>Acinetobacter</i> , <i>Pseudomonas</i> <i>putida</i> , yeasts) ^f
Ethane	<i>Methylosinus trichosporium</i> ^f , <i>Pseudomonas</i> <i>methanica</i> ^q , <i>P. putida</i> ^h
Ethylbenzene	<i>Pseudomonas putida</i> ^{aa, o}
Fluoranthene	Sewage sludge ^g <i>Pseudomonas</i> spp ^m
<i>n</i> -Heptane	<i>Pseudomonas aeruginosa</i> ^q , (<i>Arthrobacter</i> , <i>Acinetobacter</i> , <i>Pseudomonas putida</i> , yeasts) ^f
<i>n</i> -Hexane	<i>Mycobacterium smegmatis</i> ^q

Appendix C - continued.

Fuel Component/ Hydrocarbon	Microorganisms
Hexadecane	<i>Acinetobacter</i> sp. ¹ , (<i>Candida petrophilum</i> , <i>Pseudomonas aeruginosa</i> , <i>Arthrobacter</i> sp.) ¹ , <i>Micrococcus cerificans</i> (<i>Candida parapsilosis</i> , <i>C. tropicalis</i> , <i>C. guilliermondii</i> , <i>C. lipolytica</i> , <i>Trichosporon</i> sp., <i>Rhodospiridium</i> <i>toruloides</i>) ¹ , <i>Prototheca zopfii</i> (alga) ¹ , (<i>Pseudomonas putida</i> , yeasts) ¹ , <i>Nocardia</i> sp. ^{2c} , (<i>Pichia</i> , <i>Debaryomyces</i> , <i>Torulopsis</i> , <i>Candida</i>) ²ⁿ
Jet fuels	<i>Cladosporium</i> , <i>Hormodendrum</i>
Kerosene	<i>Torulopsis</i> , <i>Candida tropicalis</i> , <i>Corynebacterium hydrocarboclastus</i> (<i>Candida parapsilosis</i> , <i>C. guilliermondii</i> , <i>C. lipolytica</i> , <i>Trichosporon</i> sp., <i>Rhodospiridium toruloides</i>) ¹ , <i>Cladosporium</i> <i>resinae</i> ^{2o}
Kerosene, Jet fuel, Paraffin wax	<i>Aspergillus</i> , <i>Botrytis</i> , <i>Candida</i> , <i>Cladosporium</i> , <i>Debaromyces</i> , <i>Endomyces</i> , <i>Fusarium</i> , <i>Hansenula</i> , <i>Monilia</i> , <i>Penicillium</i> , <i>Actinomyces</i> , <i>Micromonospora</i> , <i>Nocardia</i> , <i>Proactinomyces</i> , <i>Streptomyces</i> .
Methane	<i>Pseudomonas methanica</i> ²
2-Methylhexane	<i>Pseudomonas aeruginosa</i> ²
Octadecane	<i>Micrococcus cerificans</i> ²
Naphthalene	<i>Pseudomonas</i> sp. ² , (<i>Candida lipolytica</i> , <i>C. tropicalis</i> , <i>C. Guilliermondii</i> , <i>C. maltosa</i> , <i>Debaryomyces hansenii</i>) ² , <i>Cunninghamella bainieri</i> ^{2-p} , <i>Cunninghamella</i> <i>elegans</i> ^{2-e,h} (<i>Agnenellum</i> , <i>Oscillatoria</i> , <i>Anabaena</i> , <i>Cunninghamella</i> <i>elegans</i> , <i>Microcoleus</i> sp., <i>Nostoc</i> sp., <i>Coccochloris</i> sp., <i>Aphanocapsa</i> sp., <i>Chlorella</i> sp., <i>Dunaliella</i> sp., <i>Chlamydomonas</i> sp., <i>Cylindriotheca</i> sp., <i>Amphora</i> sp.,
<i>Flavobacterium</i> ,	<i>Alcaligenes</i> , <i>Corynebacterium</i> , <i>Nocardia</i> , <i>Aeromonas</i> , stream bacteria) ² <i>Pseudomonas rathonis</i> ² , (<i>Bacillus</i> <i>naphthalenicum nonliquifaciens</i> , <i>Pseudomonas desmolyticum</i> , <i>P. fluorescens</i> ,

Appendix C - continued.

Fuel Component/ Hydrocarbon	Microorganisms
	<i>P. putida</i> biotype B) ^h , <i>Pseudomonas oleovorans</i> ^g , <i>P. putida</i> ^{f,v} , (Mucorales: <i>Cunninghamella elegans</i> , <i>C. echinulata</i> , <i>C. japonica</i> , <i>Syncephalastrum</i> sp., <i>S. racemosum</i> , <i>Mucor</i> sp., <i>M. hiemalis</i> , <i>Neurospora crassa</i> , <i>Claviceps paspali</i> , <i>Psilocybe strictipes</i> , <i>P. subaeruginascens</i> , <i>P. cubensis</i> , <i>P. stuntzii</i>) ^{aa} (<i>Pseudomonas</i> NCIB 9816, <i>P. sp.</i> 53/1 and 53/2, <i>P. desmolyticum</i> , <i>Nocardia</i> strain R, <i>Nocardia</i> sp. NRRL 3385) ^{ee} Cyanobacteria ^{ap}
Octane	<i>Pseudomonas putida</i> ^{f,v} , <i>Corynebacterium</i> sp. 7E1C ^f , <i>Pseudomonas</i> ^g
Paraffins	<i>Trichosporon pullulans</i> <i>Nocardia</i> sp. ⁱ
<i>n</i> -Pentane	<i>Mycobacterium smegmatis</i> ^g
Phenanthrene	<i>Beijerinckia</i> ^g , (<i>Pseudomonas putida</i> , <i>Cunninghamella elegans</i>) ⁿ , <i>Pseudomonas</i> spp. ^m , <i>Flavobacterium</i> ^{h,w}
Phenol	<i>(Pseudomonas, Vibrio, Spirillum, Bacillus, Flavobacterium, Chromobacter, Nocardia, Chlamydomonas ulvaensis, Phoridium foveolarum, Scenedesmus basilensis, Euglena gracilis, Corynebacterium sp.)</i> ^g (<i>Pseudomonas putida</i> , yeasts) ^m , (<i>Azotobacter</i> sp., <i>Pseudomonas putida</i> CB-173 (ATCC 31800) ^{ab} <i>Acinetobacter calcoaceticus</i> ^{af}
Pristane	<i>(Corynebacterium sp, Brevibacterium erythrogenes)</i> ^f
<i>n</i> -Propane	<i>Mycobacterium smegmatis, M. rubrum, M. rubrum var. propanicum, M. carotenum, Pseudomonas puntotropha, (Pseudobacterium subluteum, Pseudomonas methanica)</i> ^g , (<i>Cunninghamella elegans, Penicillium onatum</i>) ^f
1-Propanol > 2-propanol	<i>(Nocardia paraffinica, Brevibacterium sp)</i> ^f

Appendix C - continued.

Fuel Component/ Hydrocarbon	Microorganisms
Pyrene	Stabilization pond organisms ^a (<i>Pseudomonas/Alcaligenes</i> sp., <i>Acinetobacter</i> sp., <i>Arthrobacter</i> sp) ^k
Tetradecane	<i>Micrococcus cerificans</i> ^g (<i>Arthrobacter</i> , <i>Acinetobacter</i> , <i>Pseudomonas</i> <i>putida</i> , yeasts) ^l
Toluene	<i>Bacillus</i> sp. ^g , <i>Pseudomonas putida</i> ^{e,i,o,m,oo} , <i>Cunninghamella elegans</i> ⁿ , (<i>P. aeruginosa</i> , <i>P. mildenbergeri</i>) ^l methanogens ^{r,s} , anaerobes ^{v,t} , <i>Methylosinus trichosporium</i> QB3b ^{oo} , (<i>Pseudomonas</i> sp., <i>Achromobacter</i> sp.) ^{an} , <i>Pseudomonas aeruginosa</i> ^{am}
n-Undecane	<i>Mycobacterium</i> sp. ^g
p- and m-Xylene	<i>Pseudomonas putida</i> ^{t,oo} , methanogens ⁿ , anaerobes ^{v,t}

References:

- a = (Cerniglia and Crow, 1981)
- b = (Poglazova, Fedoseeva, Khesina, Meissel, and Shabad, 1967)
- c = (Gibson, Mahadevan, Jerina, Yagi, and Yeh, 1975)
- d = (Magor, Warburton, Trower, and Griffin, 1986)
- e = (Kobayashi and Rittmann, 1982)
- f = (Hou, 1982)
- g = (Zajic, 1964)
- h = (Cerniglia and Gibson, 1977)
- i = (Ahearn, Meyers, and Standard, 1971)
- j = (Jamison, Raymond, and Hudson, 1975)
- k = (Stetzenbach and Sinclair, 1986)
- l = (Boehn and Pore, 1984)
- m = (Ghisalpa, 1983)
- n = (Reinhard, Goodman, and Barker, 1984)
- o = (Gibson, Koch, and Kallio, 1968)
- oo = (Solanas, Pares, Bayona, and Albaiges, 1984)
- q = (Garvey, Stewart, and Yall, 1985)
- r = (Grbic-Galic and Vogel, 1986)
- s = (Grbic-Galic and Vogel, 1987)
- t = (Battermann and Werner, 1984)
- u = (Dodge and Gibson, 1980)
- v = (Jain and Sayler, 1987)
- w = (Foght and Westlake, 1985)
- x = (Rees, Wilson, and Wilson, 1985)

Appendix D - Degradation rates at certain remediation sites (from Roberts, 1992).

Initial and Final Concentrations of Compounds Susceptible to Biodegradation				
Compound	Time for Degradation	Initial Concentration	Final Concentration	Organism/Source
South Louisiana Crude Oil and Motor Oil ^a		1.0%, 5.0%		Aeromonas, Alcaligenes, Pseudomonas, Vibrio
Mixed Fuels/Solvents ^b	2 1/2 mo	22 to 45 ppm (Groundwater)	<550 ppb	
Gasoline ^c		100 to 500 ppm	2 to 5 ppm	
Methylene chloride ^d	1 yr	91 ppm (Groundwater)	<1 ppm	
Acetone ^d	1 yr	54 ppm	<1 ppm	
Acrylonitrile ^e	3 mo	1000 ppm (Groundwater)	1 ppm	Mutant bacteria
Acrylonitrile ^f	1 mo	1000 ppm	lod	Mutant bacteria
Phenol ^f	40 d	31 ppm	30 ppm	Mutant bacteria
Organic chemicals ^g		<1000 ppm (Soil)	<1 ppm	Indigenous and hydrocarbon degrading bacteria
Methylene chloride ^h	2 1/2 mo	2500 mg/l	<100 mg/l	Commercial hydrocarbon degrading bacteria
Dichlorobenzene ^h	2 1/2 mo	800 mg/l	<50 mg/l	"
p-Cresol ⁱ		8 ppm		
Hydrocarbon ⁱ		10 ppm		
Gasoline ^k	10 mo	11,500 gal/75,000 ft ²	<50 ppm	
Gasoline ^k	18 mo another 6 mo	5 to 8 ppm 2.4 ppm (Groundwater)	2.4 ppm <500 ppb	Indigenous organisms

Appendix D - continued.

Compound	Time for Degradation	Initial Concentration	Final Concentration	Organism/ Source
Gasoline ^a	25 mo (air sparging) 10 mo (m nutrient)	15 ppm (Ground-water)	2.5 ppm 200 to 1200 ppb	Indigenous organisms
Petroleum distillate ^l	21 d	12,000 ppm	> 1 ppm	BI-CHEM-SUS-8
Formaldehyde ^l	22 d	1400 ppm	> 1 ppm	PHENOAC
Phenols ^m	7 hr	1500 ppm	> 1 ppm	Azotobacter
Phenols ^m		10,000 ppm	0 to 100 ppm	
Phenol ⁿ		32 ng/g soil		
Solvent/fuel mixture (aliphatic and aromatic hydrocarbons) ^o	2-1/2 mo	23 ppm	0.5 ppm	Landfarming
Gasoline ^p	10 mo	30 to 40 ppm (groundwater)	> 1 ppm	
	10 mo	2,000 to 3,000 ppm (soil)	> 50 ppm	
Phenol ^p	7 days	5 mg/l	0 mg/l	Domestic wastewater
	7 days	10 mg/l	0 mg/l	
Naphthalene ^p	7 days	5 mg/l	0 mg/l	Domestic wastewater
	7 days	10 mg/l	0 mg/l	
Benzene ^p	7 days	5 mg/l	0 mg/l	Domestic wastewater
Benzene ^p	14 days	10 mg/l	0 mg/l	wastewater
Toluene ^p	7 days	5 mg/l	0 mg/l	Domestic wastewater
	7 days	10 mg/l	0 mg/l	
Anthracene ^p	21 days	5 mg/l	0.4 mg/l	Domestic wastewater
	21 days	10 mg/l	5 mg/l	
Phenanthrene ^p	7 days	5 mg/l	0 mg/l	Domestic wastewater
	7 days	10 mg/l	0 mg/l	
1,2-Benzanthracene ^p	7 days	5 mg/l	3 mg/l	Domestic wastewater
	7 days	10 mg/l	6 mg/l	

Appendix D - continued.

Compound	Time for Degradation	Initial Concentration	Final Concentration	Organism/ Source
Pyrene ^a	7 days 21 days	5 mg/l 10 mg/l	0 mg/l 10 mg/l	Domestic wastewater
Methanol ^a	> 30 days > 200 days	100 mg/l 1000 mg/l	< lod < lod	Soil (aerobic and anaerobic)
Tertiary butyl alcohol ^a	> 1 mo > 1 yr	10 mg/l 70 mg/l	< lod < lod	Soil
<i>m</i> -Xylene ^f		0.4 mM		Denitrifying bacteria
Aliphatic and aromatic hydrocarbons (fuels/solvents) ^a	2 1/2 mo	23 ppm	0.05 ppm	
Gasoline ^a	10 mo	30 to 40 ppm	< 1 ppm	
Formaldehyde ⁱ	24 d	> 700 ppm	1 ppm	Hydrobac tm
Toluene ^a	100 d	10,329 ppm (Groundwater)	> 10 ppb	

lod = limits of detection = 50 ppb

a = (Frieze and Oujesky, 1983)

b = (Brown, Loper, and McGarvey, 1985)

c = (Minugh, Patry, Keech, and Leek, 1983)

d = (Jhaveria and Mazzacca, 1982)

e = (Polybac Corporation, 1983)

f = (Walton and Dobbs, 1980)

g = (Ohneck and Gardner, 1982)

h = (Quince and Gardner, 1982)

i = (Pritchard, Van Veld, and Cooper, 1981)

j = (Ehrlich, Schroeder, and Martin, 1985)

k = (Brown, Norris, and Brubaker, 1985)

l = (Environmental Protection Agency, 1985b)

m = (Roberts, Koff, and Karr, 1988)

n = (Scow, Simkins, and Alexander, 1986)

o = (Niaki, Pollock, Medlin, Shealy, and Broscious, Draft)

p = (Tabak, Quave, Mashni, and Barth, 1981)

q = (Novak, Goldsmith, Benoit, and O'Brien, 1985)

r = (Zeyer, Kuhn, and Schwarzenbach, 1986)

s = (Brown, Longfield, Norris, and Wolfe, 1985)

t = (Sikes, 1984)

Appendix E - Medina product performance (from Medina, 1992).

Methods

The following is a summary of the laboratory results obtained by EPA's Risk Reduction Laboratory, Cincinnati, Ohio. Ten commercially available bioremediation products were tested for possible use in Alaska to help clean up the residual oil from the 1989 Exxon Valdez oil spill. The tests were conducted during April and May 1990, according to a defined protocol made known before the tests. This protocol involved placing the products in seawater from Prince William Sound, together with weathered Prudhoe Bay crude oil. To assure objectivity during the testing, the 10 treatments were designated by alphabetical codes A through J. Therefore, the results are represented on a coded basis.

Results

The results of the laboratory study indicate that Medina Soil Activator produced notable alkane reductions in the combination of seawater and weathered Prudhoe Bay crude oil.

- At day 11, tests showed reductions of 67.8% compared to 27.6% for the benchmark test with no additives. At day 20, tests showed reductions at 90.6%, compared to benchmark at 25.2%.

Study Conducted by:
 National Environmental
 Technology Applications Corp.
 University of Pittsburgh Applied
 Research Center for the U.S.
 Environmental Protection Agency
 Risk Reduction Laboratory

Study Dates:
 April - May 1990

Location:
 Laboratory

Total Alkane Reduction Day 11

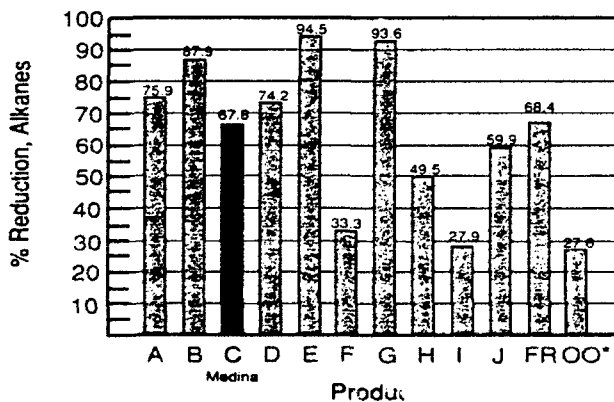

Total Alkane Reduction Day 20

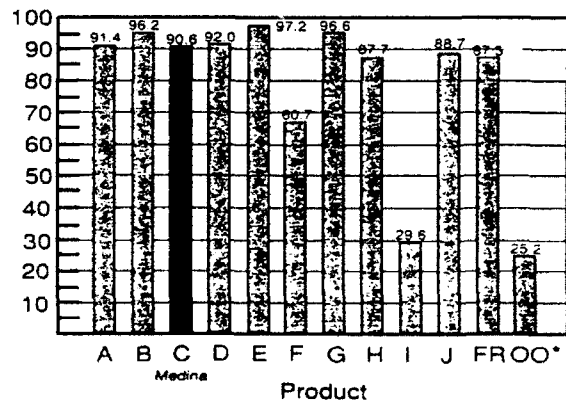

* OO - Benchmark, no additives

Appendix F - Inipol EAP 22 product performance (from Elf Aquitaine, 1992).

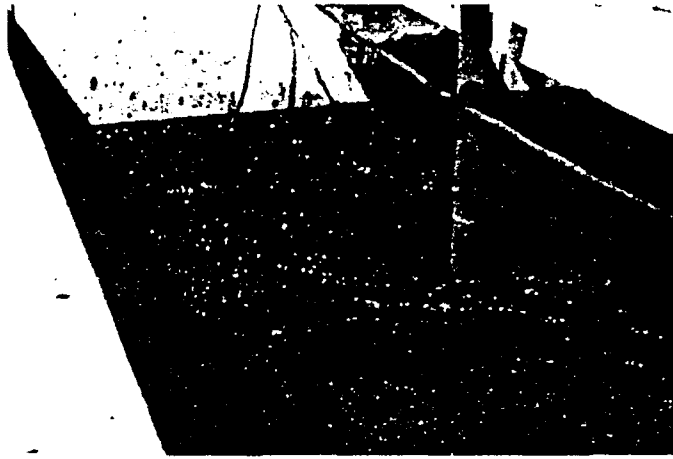

1 - After 7 days without EAP 22 treatment.

**TEST N° 1 -
MEDITERRANEAN SEA**

Temperature 12 °C
 Crude Oil Zarzaitine/Ashtart 30/70 %
 Treatment INIPOL EAP 22 3%
 Duration 7 days
 Disparition rate of oil 69%

The reduction effected by natural evaporation, under the same conditions, was only 11 %.

Without INIPOL EAP 22 the oil became a thick and stable emulsion (chocolate mousse) containing 75 % water.

**TEST N° 2 -
MEDITERRANEAN SEA**

Temperature 18 °C
 Crude Oil M'Wengui
 Treatment INIPOL EAP 22 5%
 Duration 7 days
 Disparition rate of oil 78%

The reduction effected by natural evaporation, under the same conditions, was only 17 %.

Without INIPOL EAP 22 the oil became a chocolate mousse containing 67 % water.

**TEST N° 3 -
ANTARCTIC OCEAN**

Temperature 3° to 8 °C
 Crude Oil Arabian light
 Treatment INIPOL EAP 22 8%
 Duration 7 days
 Disparition rate of oil 87%

The reduction effected by natural evaporation, in very high winds, was only 8 to 10 %.

**TEST N° 4 -
ANTARCTIC OCEAN**

Temperature 3° to 8 °C
 Crude Oil Arabian light
 Treatment INIPOL EAP 22 3%
 Duration 21 days
 Disparition rate of oil 94%

The reduction effected by natural evaporation, under the same conditions, was only 17 %.

From these last two experiments, it is interesting to note that the temperature does not seem to restrict the biodegradation when the micro-organisms present are acclimatised.

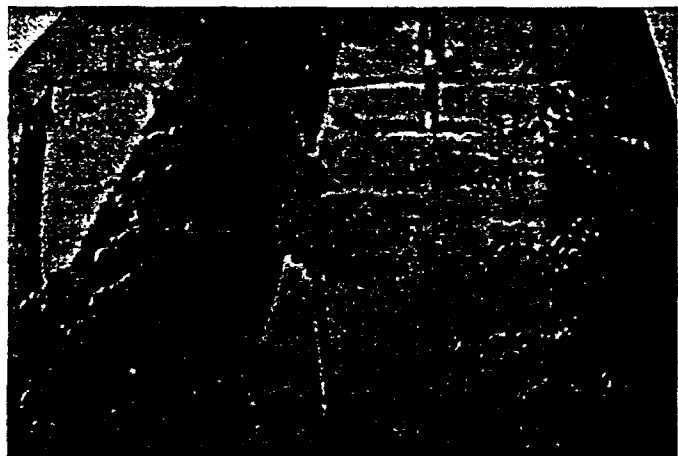

2 - After 7 days with treatment.

Appendix G - WMI-2000 product uses (from Waste Microbes, Inc., 1992).

The following partial list of projects indicates that Waste Microbes, Inc. has effectively remediated liquid and weathered hydrocarbons in a number of applications. These are typical examples of WMI capability to evaluate, design, and implement remediation of organic and hydrocarbon wastes.

<u>1000-Acre Terminal</u> Texas	Bioremediated 2-acre stormwater pond which remained in service, receiving terminal storm water, tank bottom draws, and spills. The pond contained 4.5 feet of sludge consisting of hydrocarbon waste (72% oil and grease). Oil and grease levels were reduced by 92 percent. This pond is now under maintenance contract.
<u>Petroleum Products Farm</u> Texas	Treated a small holding pond which receives waste oil and gasoline Tank from the terminal. There are 800 yds ³ of organic sludge present with a very high oil and grease content in the sludge. Currently under maintenance contract.
<u>Chemical Packager</u> Texas	Treated oil-contaminated soil with one microbial formulation. Also Central treating septic system with WMI municipal culture.
<u>Railroad</u> Texas	WMI-2000 was used to digest weathered diesel fuel heavy ends in a railroad yard pond. The heavy dispersed oils and 1-inch thick floating sludge were digested in one week. The culture then digested sludges as deep as 4 feet beneath the water over a period of about 9 months.
<u>Major Railroad</u> California Louisiana Texas	Cleaning, repair, and fueling activities on-going at ten locations. Treatment is designed for biodegradable detergents, diesel, grease and oils which are present in biological ponds and soil contamination. These are Class I hazardous hydrocarbons. The system has been in place four years.
<u>Tank Farm Terminal</u> Texas	Treated two waste oil tanks and a DAF unit containing toxic and hazardous oils and sludges.
<u>University</u> Pennsylvania	Participated in testing with EPA and NETAC concerning VALDEZ crude oil and Prince William Sound seawater. WMI-2000 bacterial culture was in the top three cultures evaluated.

HERSLEV DOMESTIC WASTE TREATMENT PLANT

Herslev, Denmark

Project: An active primary waste treatment plant - 2,500 person equivalent.

Result: Project completed - 2 year demonstration

The BOD was reduced to 5ppm, the ammonia reduced to non detect and the sludge reduced by 75%.

ODEEN HIBBS TRUCKING COMPANY

Austin, Texas

Project: Cleanup of a diesel contaminated pond and soil. 1,200 square yards

Result: Project completed - in 2 weeks

The contamination was cleaned to non-detect levels as specified by The Texas Water Commission.

CHEVRON OIL COMPANY

New Iberia, Louisiana

Project: The closure of a staging area for offshore production (50,000 cubic yards 60% hydrocarbon dry weight). Three acre oil pit - 15 feet deep. In-Situ bioremediation followed by land farming. Analysis of samples of the land farming has shown a residual of less than 500 ppm.

Result: Project is currently in progress (85% complete) - 18 months

MOBIL OIL GAS STATION

Austin, Texas

Project: Sump pit for gas station wastes. The pit contained automobile waste oil, which had an extremely foul odor.

Result: Project completed - in 14 days

The odor disappeared and the oil was reduced to a non visual state that was accepted by waste treatment mains.

BERGSTROM AIR FORCE BASE

Austin, Texas

Project: 300 cubic yards of diesel contaminated above ground soil.

Result: Project completed - in 21 days

The soil was remediated to below detection limits as specified by The Texas Commission.

Appendix I - Rotary wing aircraft for aerial application (from ITOFP, 1992).

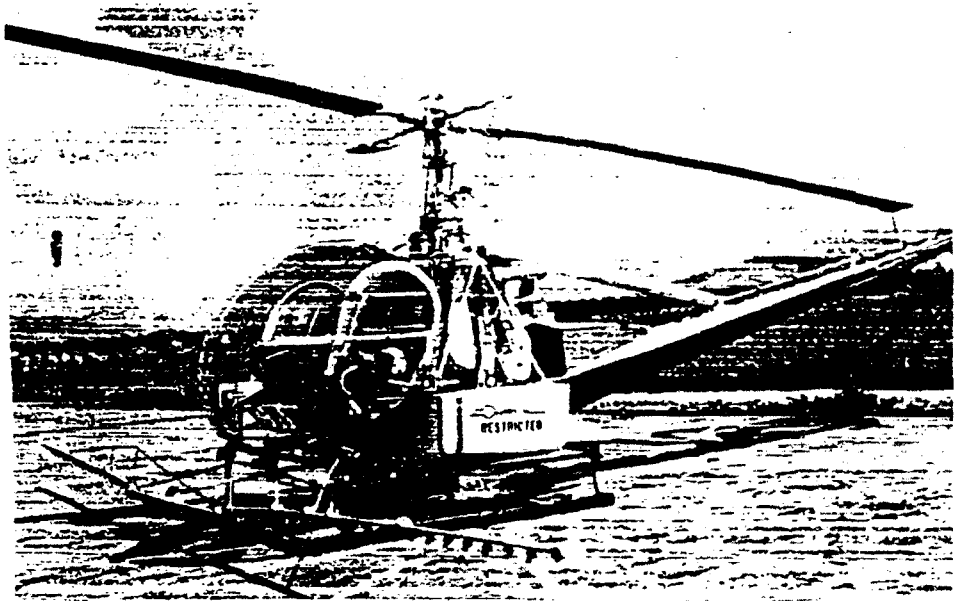
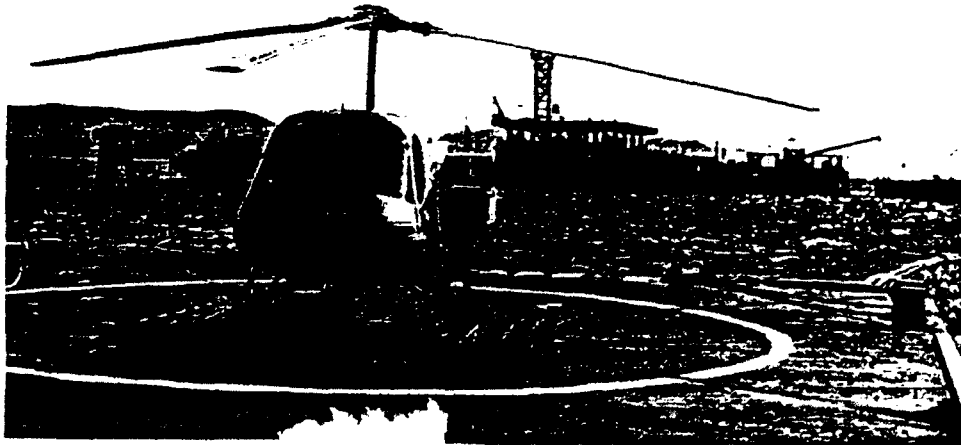
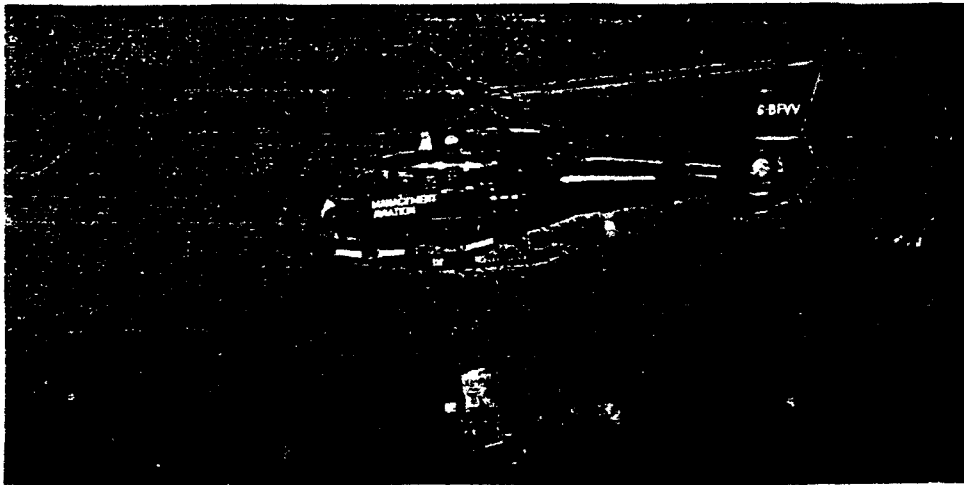
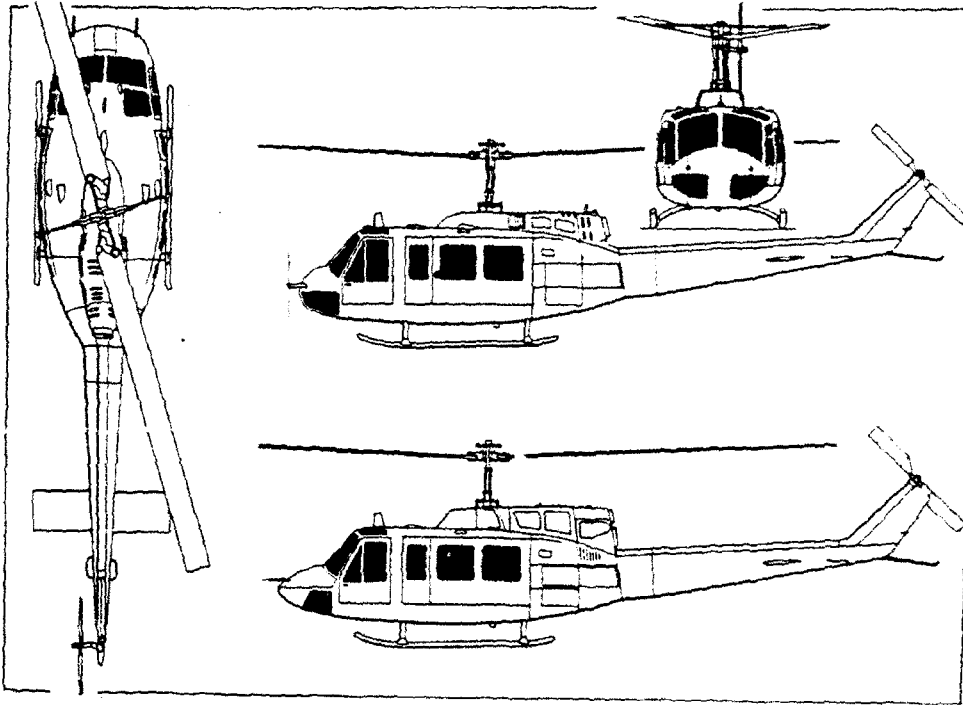

Photo by [unreadable] [unreadable] [unreadable]



Appendix I - Rotary wing aircraft for aerial application (from
Janes, 1985).



Bell UH-1H Iroquois, with additional side view (bottom) of UH-1N (Pilot Press)

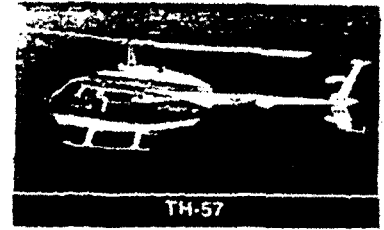

TH-57



HH-65A

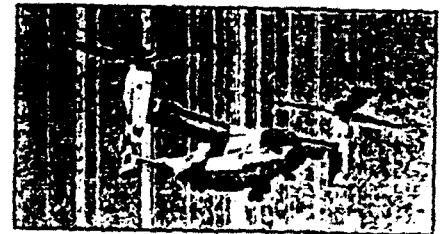
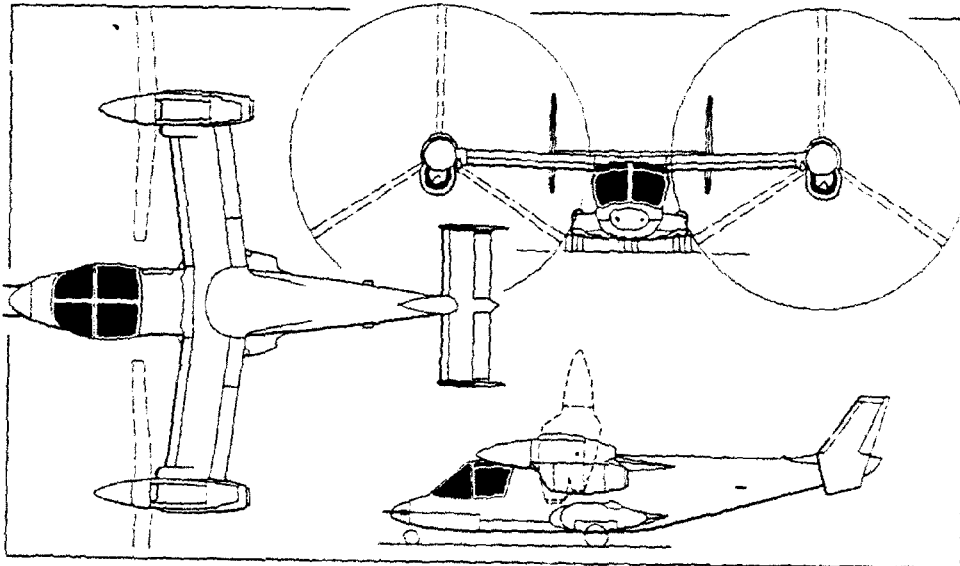
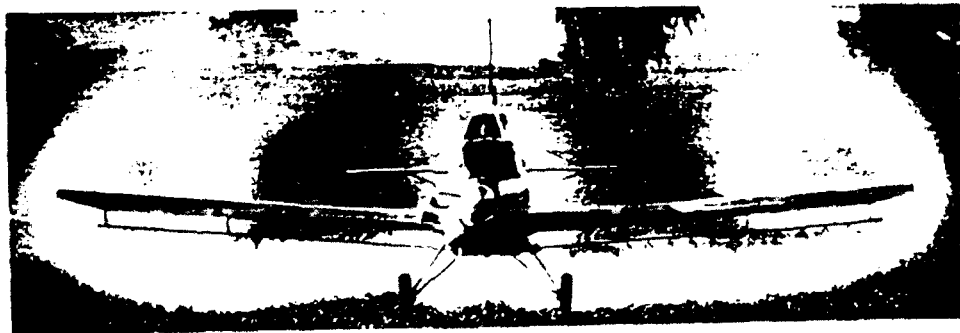
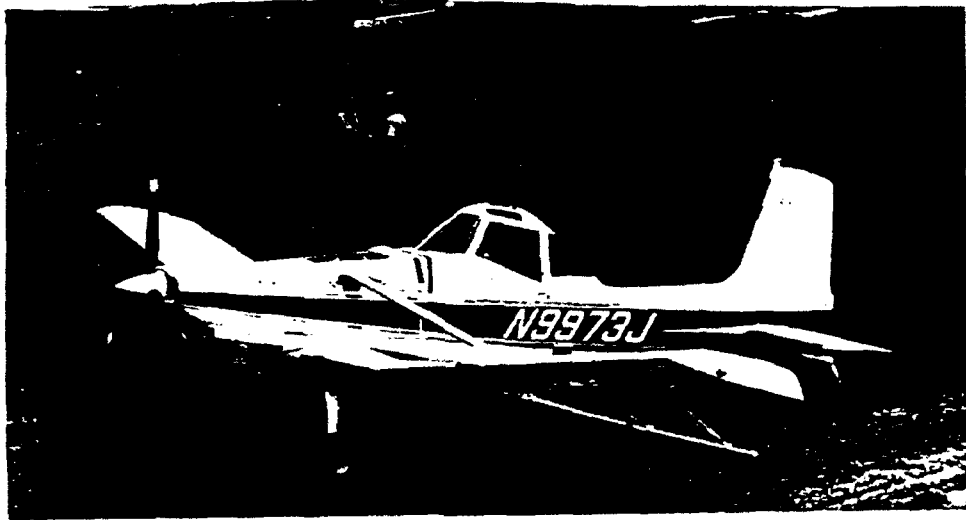
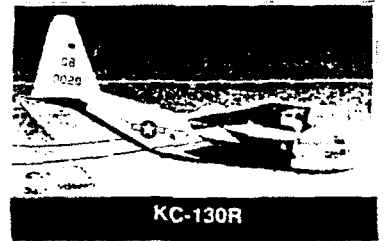
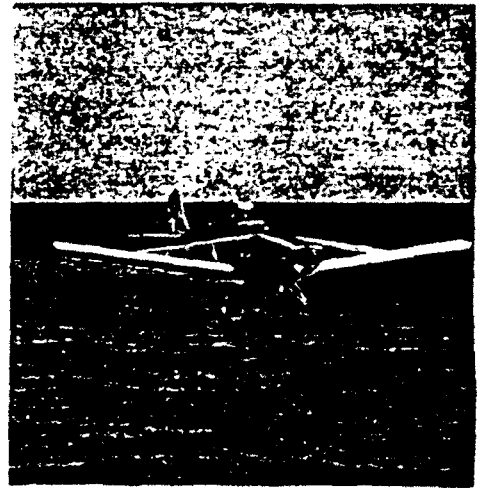
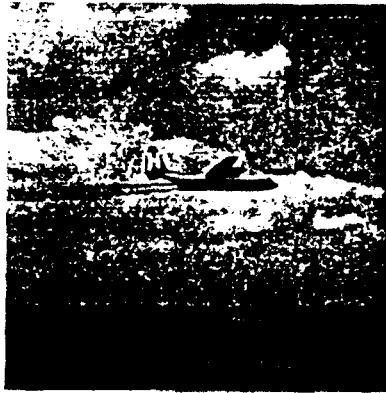

Figure: A V-22 Tiltrotor aircraft displays the helicopter mode. The engines rotate forward for airplane mode.

Appendix J - Fixed wing aircraft for aerial application (from ITOFF, 1992, and Janes, 1985).



Appendix J - Fixed wing aircraft for aerial application
(from ITOFF, 1992).

CHARACTERISTICS OF TYPICAL AIRCRAFT SUITABLE FOR AERIAL SPRAYING
OF DISPERSANT

<i>Aircraft Type</i>	<i>Propulsion</i>	<i>Dispersant tank capacity (litres)</i>	<i>Transit speed (knots)</i>	<i>Minimum runway length (metres)</i>
Purpose-built single-engined agricultural aircraft				
Aerospace Fletcher Cresco	Turbine	1530	140	300
Aerospace Fletcher	Piston	1045	115	245
Antonov An 2 R	Piston	1400	100	150
Basant	Piston	900	100	215
Cessna Agtruck	Piston	1060	100	400
Desmond Norman Fieldmaster	Piston	2640	145	175
EBM 701 Ipanema	Piston	680	105	465
IAR-822	Piston	600	80	300
Pilatus Porter PC-6	Turbine	950	110	180
Piper Brave 300	Piston	850	125	295
Piper Pawnee D	Piston	570	90	245
PZL Dromader M18	Piston	2500	100	250
PZL 106A Kruk	Piston	1400	90	220
Super AgCat B	Piston	1135	100	180
Thrush Commander	Piston	1365	100	300
Turbo Thrush	Turbine	2275	125	250
Transavia Air Truk	Piston	820	95	335
Converted single & multi-engined aircraft				
Helicopters (fuselage mounted)				
Aérospatiale Lama	1 turbine	1140	80	—
Aérospatiale AS 350	1 turbine	1100	120	—
Bell 47	1 piston	400	75	—
Bell 206	1 turbine	680	115	—
Bell 212	2 turbine	1515	125	—
Hiller UH-12E	1 piston	500	80	—
Hughes 500	1 turbine	680	115	—
Enstrom F-28C	1 piston	400	70	—
Fixed wing				
Beech Baron	2 piston	450	200	410
BN Islander	2 piston	480	140	170
BN Trislander	3 piston	1250	145	395
Canadair CL 215	2 piston	5300	160	915
DC3	2 piston	4600	130	1000
DC4	4 piston	9460	190	1525
DC6	4 piston	13250	210	1525
Grumman Avenger	1 piston	2000	200	915
Piper Aztec	2 piston	570	175	300
Shorts Sky Van	2 turbine	1200	170	510
Twin Otter	2 turbine	2100	170	320
Volpar Turbo Beech 18	2 turbine	1100	220	510

Appendix K - Vessels of opportunity (from Offshore, 1990).

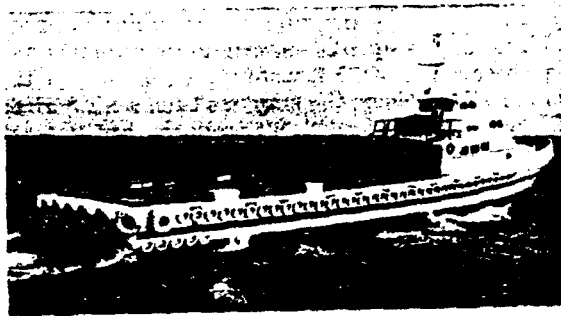
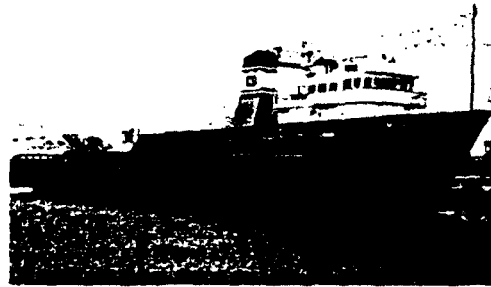

Appendix I - Terra-gator models and specifications (from Ag-Chem Equipment, 1992).

Terra-Gator® 2505

4000 gallon capacity

The Terra-Gator 2505 liquid sludge system has a 4,000 gallon rated capacity and injects material to 14" depths at rates of 17,000 gallons per hour—up to 170,000 gallons per 10 hour day. This total cycle time of 17,000 gph is based on in-field nursing or on-site material storage.

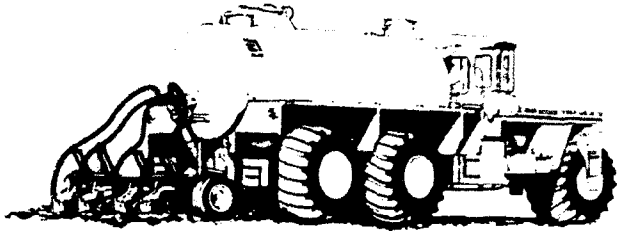

Terra-Gator® 004

3100 gallon capacity

You choose the system size for the Terra-Gator 004—either 3,100 or optional 3,500 gallon rated capacity. Both size systems inject liquid waste up to 11 percent solids content at 10 inch depths with the standard injection system. An optional heavy-duty system places waste at depths to 14 inches (with 3,100 gallon tank only).

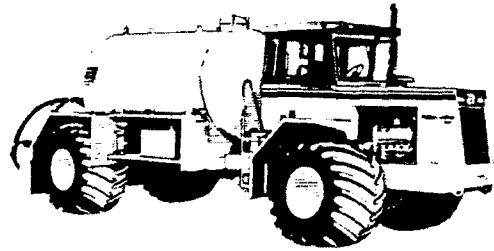

Terra-Gator® 2204

2200 gallon capacity

The Terra-Gator 2204 offers a field-efficient sludge applicator priced comparably to converted trucks. The 2,200 gallon rated pressure/vacuum system loads and empties in about 2½ minutes. With in-field nursing or on-site storage the 2204 will subsurface inject or surface spray up to 120,000 gallons in a 10 hour day.

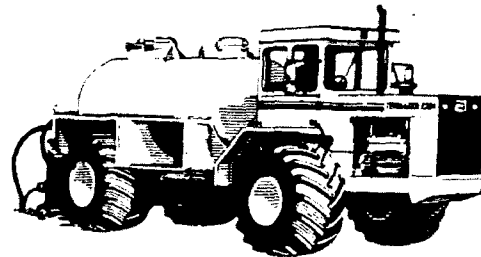

Terra-Gator® 1664T

2000 gallon capacity

The Terra-Gator 1664 is a 2-wheel drive applicator engineered to operate in the roughest off-road conditions. The 2,000 gallon rated system places waste to 10 inch depths—right at crop root levels.

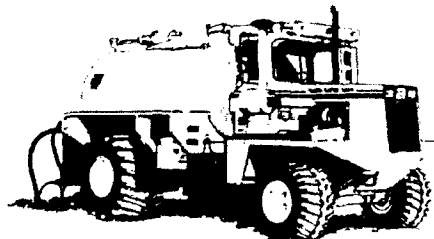

Appendix M - Aircraft nozzles- pressure and rotary (from ITOPF, 1992).

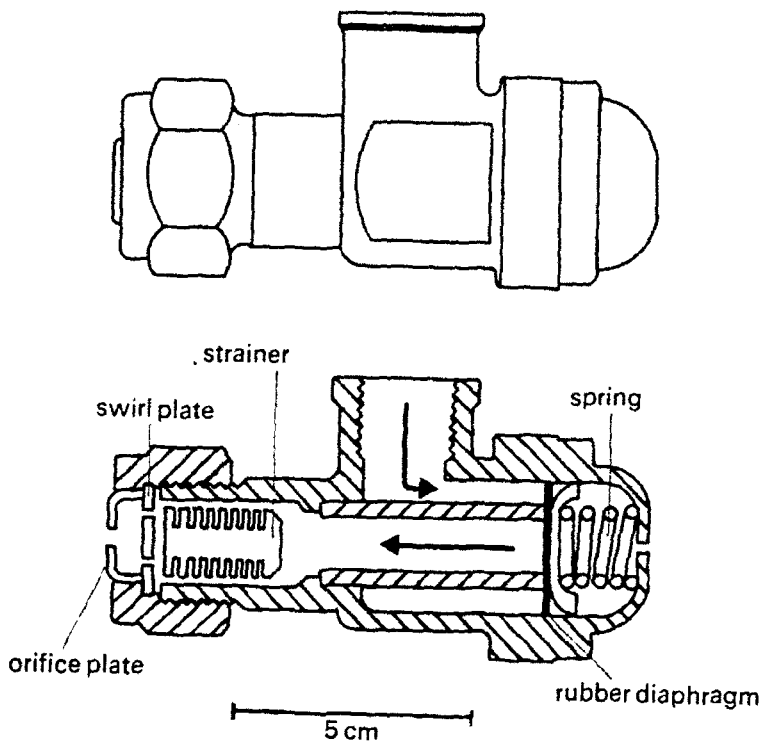

Pressure nozzle.

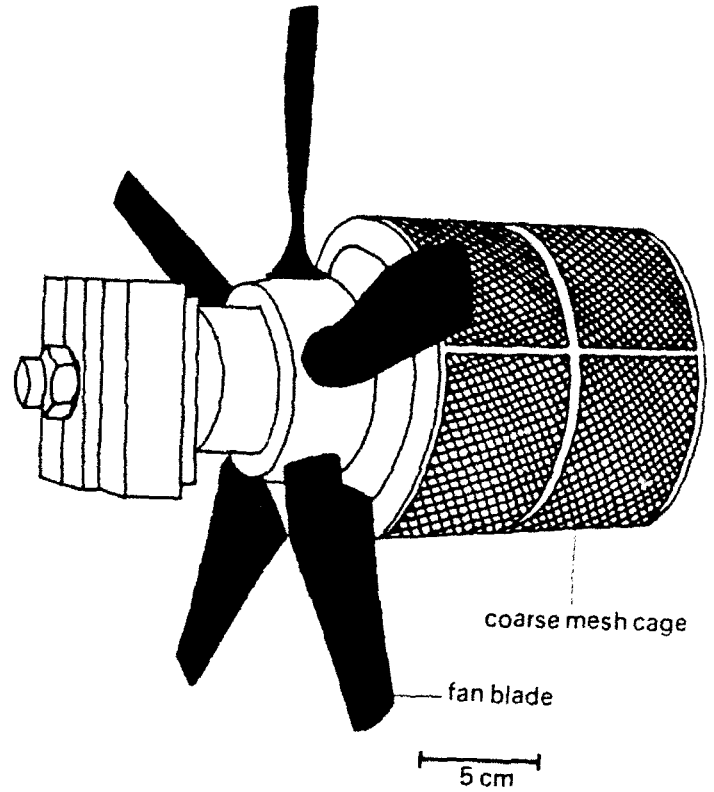
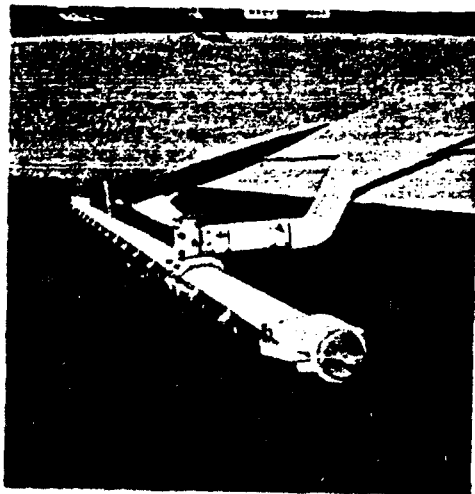

Rotary atomizer.

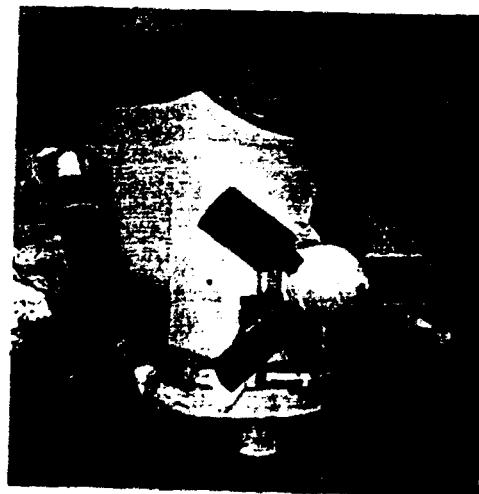

Appendix N - Typical boom assemblies (from ITOPF, 1992).

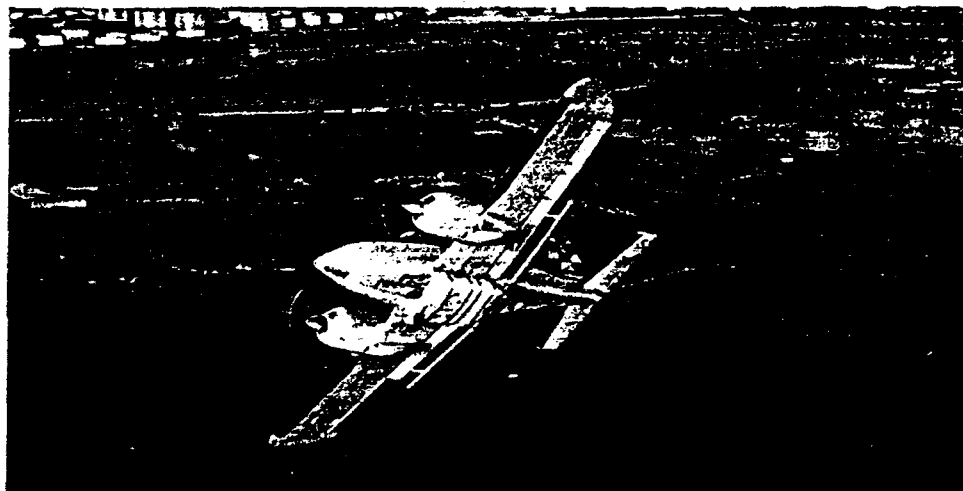

Appendix N - Typical spray boom assemblies (from Onstad, 1989, and ITOPF, 1992).

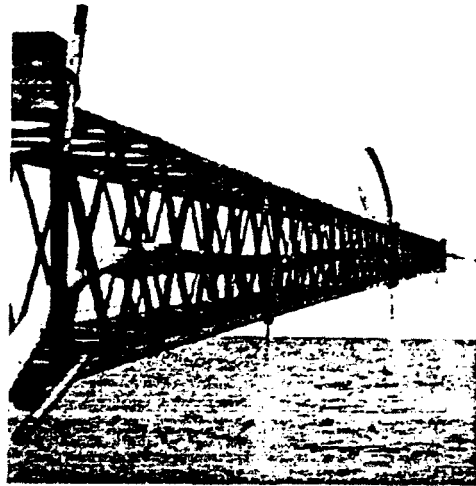
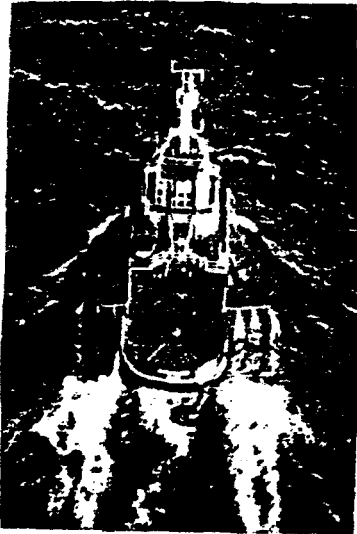
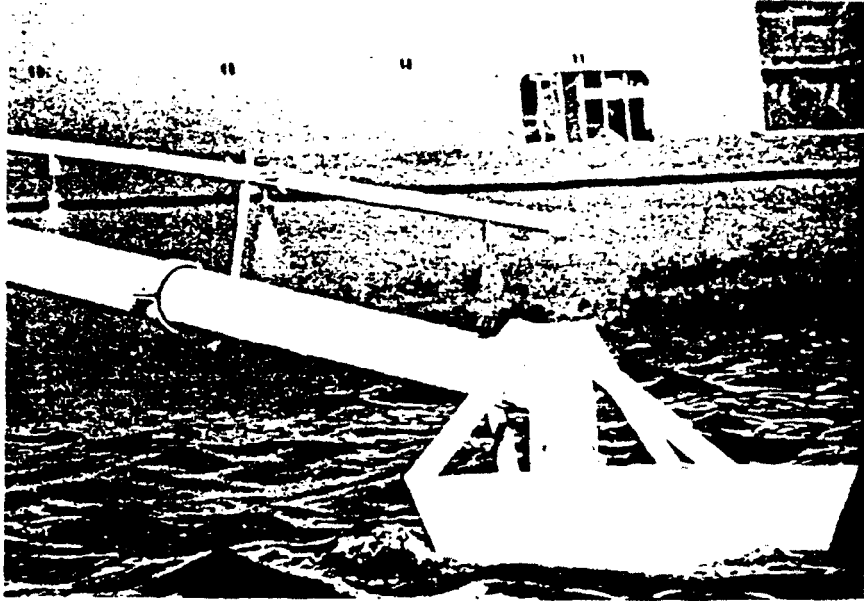

Appendix O - Typical hose systems (from Owens, 1984, and Kaufmann, 1984).

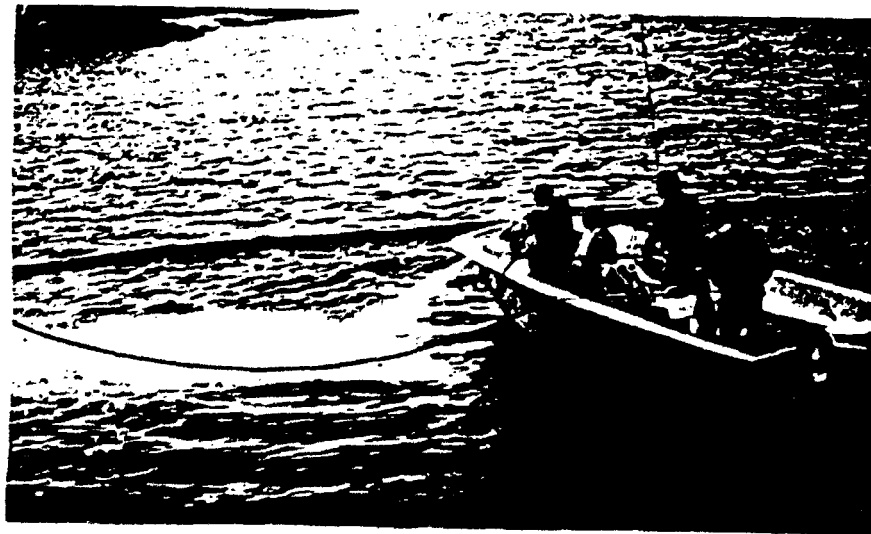
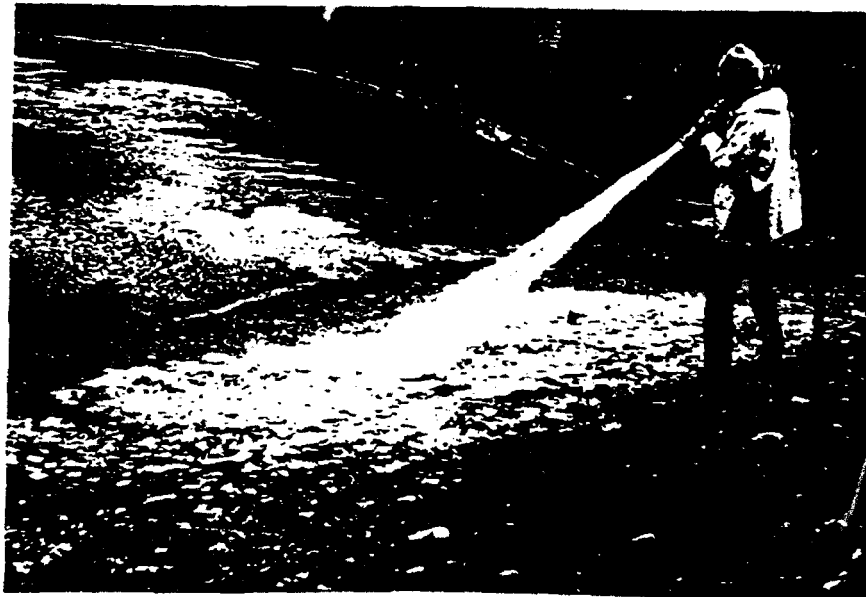
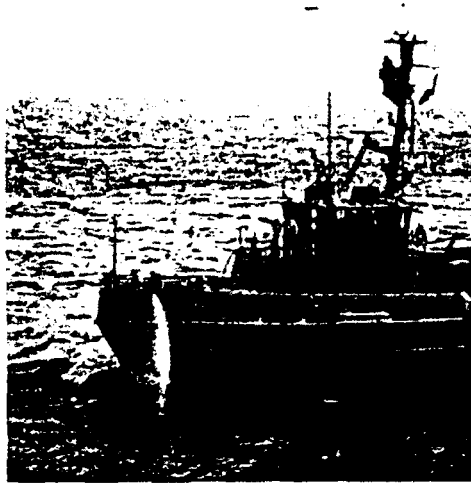

Shipped From Inventory*

2,000 / 5,000 / 10,000 / 20,000 / 30,000 / 50,000 / 100,000 gallon tanks

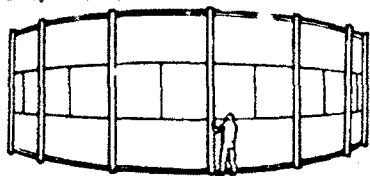

ModuStor

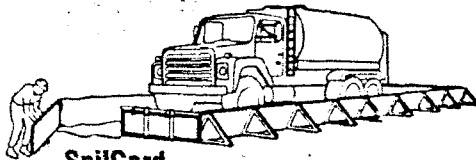

SpilGard

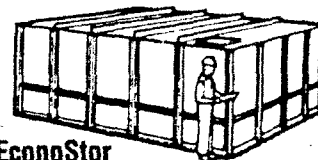

EconoStor



PermaStor

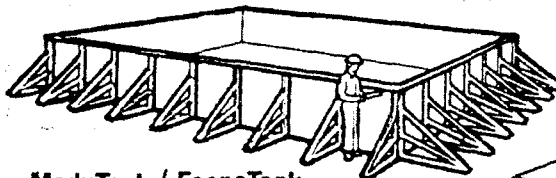

ModuTank / EconoTank

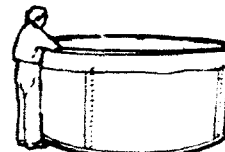

QuickStor

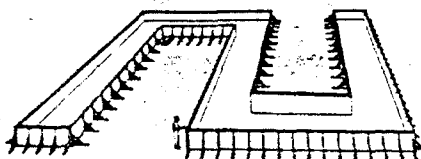

Special Shapes

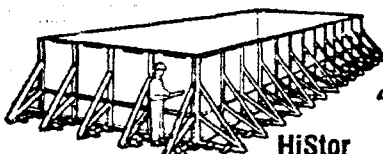

HiStor

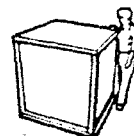

ComPakt

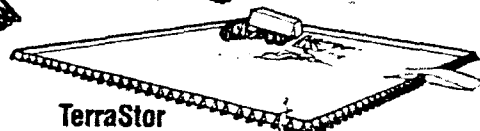

TerraStor

ModuTank™ 8,000—unlimited gallons
Designed for heavy-duty permanent or standby containment, low-cost ModuTanks feature modular steel components for rapid bolt-together assembly on any firm, level surface.

EconoTank™ 8,000—unlimited gallons
EconoTanks, similar in construction to ModuTanks are engineered specifically for short-term containment and cost as little as 4¢/gallon for a two million gallon tank.

Special Shapes Virtually any shape utilizing right angles such as "T" - "L" - "Cross" etc. can be assembled from ModuTank's unique, modular components. This capability is especially useful for installations with special flow requirements or irregularly shaped sites.

HiStor™ 100,000—unlimited gallons
High-capacity 6'-3" high HiStor tanks, offering more than 30% greater holding capacity than ModuTanks, are preferred choices for heavy-duty standby or permanent storage.

ComPakt™ 250 gallons and up
Small capacity tanks for permanent or standby storage indoors or outdoors. Modular steel components hand carry through doorways for assembly in tight interior spaces.

QuickStor™ 2,200—35,000 gallons
QuickStor, as low as 10¢/gallon ... for temporary

or emergency containment...for almost instant setup ...for short-term storage during spill clean up.

EconoStor™ 2,000—18,000 gallons
These tanks fit anywhere. Low-cost EconoStors utilize compact heavy-duty components for hand carrying and rapid bolt-together assembly in hard-to-reach places.

AlumStor™ 500—10,000 gallons
AlumStor storage and feed systems are designed for converting water treatment plants from dry to liquid alum for operational savings up to 30%.

ChemStor™ 500—10,000 gallons
All the features of the versatile EconoStor, but specially engineered for liquid chemical storage.

PermaStor™ 100,000 gallons and up
PermaStor, an 8'-high steel tank system, is designed for long-term fixed position installations.

ModuStor™ 8,000—850,000 gallons
ModuStor's prefabricated bolt-together steel wall panels rapidly assemble into a wide range of tank sizes from 15 to 100 feet in diameter and from 4 to 15 feet high.

SpilGard™ 7,500—22,700 gallons
SpilGards are designed to contain accidental

tanker truck spills at loading and storage points.

TerraStor™ 500—unlimited cubic yards
Low-cost TerraStor containment systems are ideal answers for the temporary storage and treatment of hazardous earth materials, sand and clay.

ModuTainer™ 2,200—unlimited gallons
Low-cost ModuTainer systems in rectangular or round configurations are designed for assembly around existing or new tank installations.

Ponds & Liners 500—unlimited gallons
ModuTank Inc. offers factory fabricated and field installed membrane liners for ponds and new or existing tanks.

*EconoTank

Discover why more than 65 Fortune 500 companies have purchased ModuTank Inc. products. ASK FOR A FREE CATALOG

ENGINEERED CONTAINMENT SYSTEMS SINCE 1961

ModuTank Inc.

41-04 35th Avenue, Long Island City, NY 11101

800-245-6364 (In NY 718-392-1112)

Appendix Q - Typical packaged units (from ITOFF, 1992).

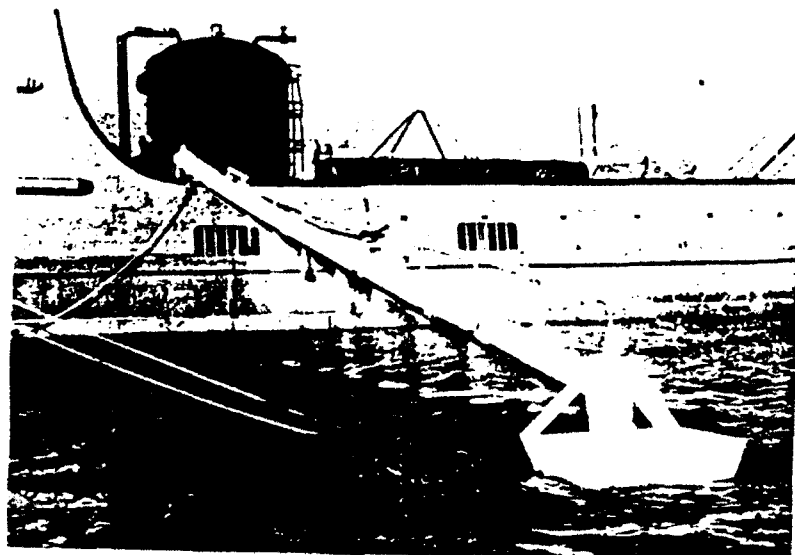
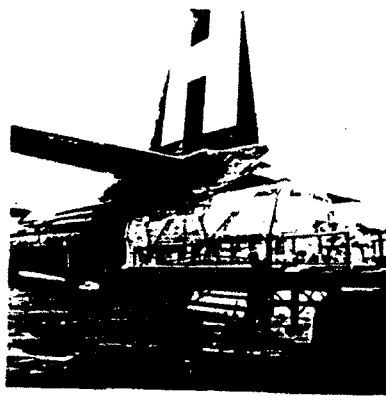
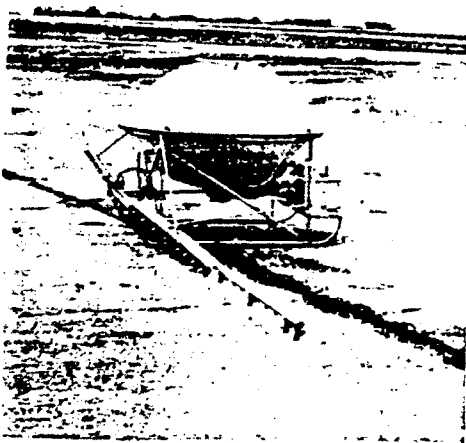
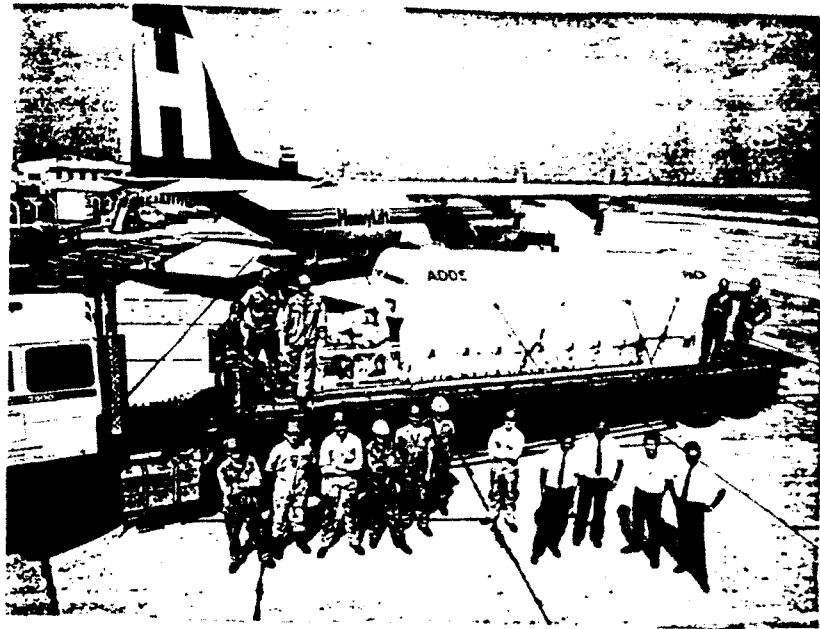

ENHANCED IN SITU BIODEGRADATION OF PETROLEUM HYDROCARBONS THROUGH SOIL VENTING

RDV 91-7

July 1991

SYNOPSIS

This technology can be applied to the cleanup of unsaturated soils contaminated with petroleum hydrocarbons.

Soil venting is effective for the physical removal of volatile hydrocarbons from unsaturated soils. Vadose zone or unsaturated soils are those which lie above the water table. This technology can also provide oxygen for the biological degradation of hydrocarbons in contaminated soil. Common strains of soil bacteria are capable of biodegrading hydrocarbon contaminants. Treatment of the off-gas from a soil venting system can contribute up to 50 percent of the overall cost of the remediation system. Through the optimization of venting air flow rates, the amount of hydrocarbon removal attributed to *in situ* biodegradation can be greatly increased. This approach may eliminate the need for off-gas treatment, thereby reducing overall site remediation costs.

A pilot-scale field test of bioventing was conducted at a JP-4 jet fuel contamination site at Tyndall AFB. The soil in the area of the spill site consisted of very fine to fine unconsolidated quartz sands with trace occurrences of organic material. Soil hydrocarbon concentrations ranged from 30 to 23,000 mg/kg soil and soil moisture content ranged from 6.5 to 9.8 percent.

Two enclosed plots of contaminated soil (4.9 meters x 1.8 meters x 1.5 meters deep) were constructed. An air venting and a nutrient/moisture delivery system were installed in each plot. The

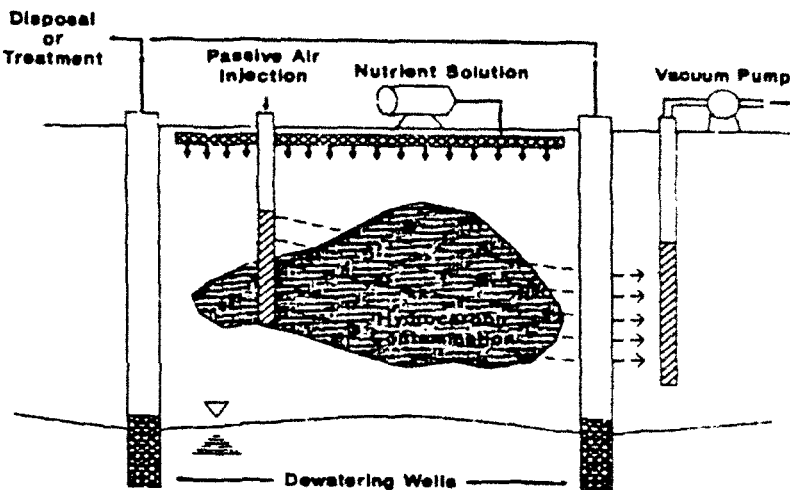

Plots were operated under varying air flow rates and varying nutrient/moisture conditions for 188 days. Two similar plots were also constructed in uncontaminated soil. One was used to determine the amount of background respiration and the other used to evaluate the potential for biodegradation of hydrocarbon vapors by passing the off-gas from one of the contaminated plots through the uncontaminated soil.

Measured biodegradation rates within the soil cells ranged from 2 to 20 mg/kg/day. Nutrient and moisture addition had no significant effect on biodegradation rate. Biodegradation rate constants were affected by soil temperature and followed the predicted values based on the van't Hoff-Arrhenius equation. The amount of hydrocarbon removal attributed to *in situ*

biodegradation could be increased to 85 percent by management of the venting air flow rate.

When contaminated off-gas was passed through a plot of clean soil the contaminants in the airstream were biodegraded by the naturally occurring microorganisms. Results from pre- and post-sampling of soil showed that the contaminants were not removed by sorption onto the soil particles. Based on the data collected at this site, a soil volume ratio of approximately 4 to 1, uncontaminated to contaminated soil, would be required to biodegrade the off-gas from a similarly operated bioventing system.

Cost estimates for an operational bioventing treatment system range from \$12 to \$15 per cubic yard of soil, assuming no treatment of the off-gas emissions will be required.

Vita

Mark Richard Deibert
Lieutenant, Civil Engineer Corps, United States Navy

Graduated from Oklahoma State in 1985 with a Bachelor of Science in Civil Engineering.

Attended the United States Navy Officer Candidate School at Newport, Rhode Island in 1986 and was commissioned an Ensign.

Reported to NAS Cecil Field, Jacksonville , FL as the Assistant Public Works Officer in 1986.

Reported to NAF Atsugi Japan as the Assistant Resident Officer in Charge of Construction in 1988.

Is a registered professional engineer in the state of Minnesota.