

NIST NCSTAR 1-4C

**Federal Building and Fire Safety Investigation of the
World Trade Center Disaster**

Fire Alarm Systems

Robert J. Keough
Raymond A. Grill

NIST NCSTAR 1-4C

**Federal Building and Fire Safety Investigation of the
World Trade Center Disaster**

Fire Alarm Systems

Robert J. Keough
Raymond A. Grill
Rolf Jensen and Associates

September 2005



U.S. Department of Commerce
Carlos M. Gutierrez, Secretary

Technology Administration
Michelle O'Neill, Acting Under Secretary for Technology

National Institute of Standards and Technology
William Jeffrey, Director

Disclaimer No. 1

Certain commercial entities, equipment, products, or materials are identified in this document in order to describe a procedure or concept adequately or to trace the history of the procedures and practices used. Such identification is not intended to imply recommendation, endorsement, or implication that the entities, products, materials, or equipment are necessarily the best available for the purpose. Nor does such identification imply a finding of fault or negligence by the National Institute of Standards and Technology.

Disclaimer No. 2

The policy of NIST is to use the International System of Units (metric units) in all publications. In this document, however, units are presented in metric units or the inch-pound system, whichever is prevalent in the discipline.

Disclaimer No. 3

Pursuant to section 7 of the National Construction Safety Team Act, the NIST Director has determined that certain evidence received by NIST in the course of this Investigation is "voluntarily provided safety-related information" that is "not directly related to the building failure being investigated" and that "disclosure of that information would inhibit the voluntary provision of that type of information" (15 USC 7306c).

In addition, a substantial portion of the evidence collected by NIST in the course of the Investigation has been provided to NIST under nondisclosure agreements.

Disclaimer No. 4

NIST takes no position as to whether the design or construction of a WTC building was compliant with any code since, due to the destruction of the WTC buildings, NIST could not verify the actual (or as-built) construction, the properties and condition of the materials used, or changes to the original construction made over the life of the buildings. In addition, NIST could not verify the interpretations of codes used by applicable authorities in determining compliance when implementing building codes. Where an Investigation report states whether a system was designed or installed as required by a code *provision*, NIST has documentary or anecdotal evidence indicating whether the requirement was met, or NIST has independently conducted tests or analyses indicating whether the requirement was met.

Use in Legal Proceedings

No part of any report resulting from a NIST investigation into a structural failure or from an investigation under the National Construction Safety Team Act may be used in any suit or action for damages arising out of any matter mentioned in such report (15 USC 281a; as amended by P.L. 107-231).

**National Institute of Standards and Technology National Construction Safety Team Act Report 1-4C
Natl. Inst. Stand. Technol. Natl. Constr. Sfty. Tm. Act Rpt. 1-4C, 148 pages (September 2005)
CODEN: NSPUE2**

U.S. GOVERNMENT PRINTING OFFICE
WASHINGTON: 2005

For sale by the Superintendent of Documents, U.S. Government Printing Office
Internet: bookstore.gpo.gov — Phone: (202) 512-1800 — Fax: (202) 512-2250
Mail: Stop SSOP, Washington, DC 20402-0001

ABSTRACT

This report was prepared to support the investigation of active fire protection systems as part of the National Institute of Standards and Technology (NIST) World Trade Center (WTC) Investigation.

The purpose of this report is to document the design, installation, and modifications to the fire detection and alarm system for buildings 1, 2, and 7 of the WTC, including system performance during the September 11, 2001, attack.

Keywords: Fire alarm systems, fire protection, smoke detection, voice communication, World Trade Center.

This page intentionally left blank.

TABLE OF CONTENTS

Abstract	iii
List of Figures	ix
List of Tables	xi
List of Acronyms and Abbreviations	xiii
Glossary	xv
Preface	xvii
Executive Summary	xxvii
Chapter 1	
Introduction	1
1.1 Purpose.....	1
1.2 History of Fire Alarm Systems	1
1.3 WTC 1, 2, and 7 Introduction	2
Chapter 2	
Normal Operations and Fire Emergency Response	9
2.1 Fire Command Station	9
2.2 WTC 1 and WTC 2 Operations Command Center	10
2.3 Fire Prevention and Fire Preparedness Procedures.....	10
2.3.1 Fire Drills	10
2.3.2 Training Exercises	10
2.3.3 Fire Prevention Inspections	10
2.4 Alarm Notification	11
2.5 Fire Safety Plan.....	11
2.6 Fire Department Response.....	12
2.6.1 Alarms	12
2.6.2 Communication	13
2.6.3 Support from Neighboring Fire Departments.....	13
Chapter 3	
Original Fire Alarm System Prior to the 1993 Bombing and Modifications	
Subsequent to 1993	15
3.1 Fire Alarm System	15
3.1.1 Description	16

3.2	Smoke Detection and Alarm Systems.....	22
3.2.1	Interior Return Air Smoke Alarm System.....	22
3.2.2	Elevator Lobby Smoke Alarm System.....	23
3.2.3	Ventilation Smoke Alarm System.....	23
3.2.4	Tenant Smoke Alarm Systems.....	27
3.3	Public Address System.....	27
3.3.1	Speaker System.....	27
3.4	Public Address Console.....	30
3.5	Sprinkler Waterflow Alarm System.....	31
3.5.1	Component Descriptions.....	32
3.6	Standpipe Fireline Communication System.....	33
3.7	Comparison of the Pre-1993 and Post-1993 Fire Alarm Systems.....	35
3.7.1	General.....	35
3.7.2	Fire Command Station Pre-1993.....	36
3.7.3	Fire Command Station Post-1993.....	36
3.7.4	Base Building Fire Alarm System Pre-1993.....	37
3.7.5	Base Building Fire Alarm System Post-1993.....	37
3.7.6	Detection, Monitoring, and Control Devices Pre-1993.....	38
3.7.7	Detection Monitoring, and Control Devices Post-1993.....	39
3.7.8	Notification Appliance Devices Pre-1993.....	40
3.7.9	Notification Appliance Devices Post-1993.....	40
3.7.10	Warden and Standpipe Fireline Communication System Pre-1993.....	40
3.7.11	Warden and Standpipe Fireline Communications System Post-1993.....	41
Chapter 4		
Fire Alarm System Performance Requirements.....		43
4.1	General Fire Alarm Requirements.....	44
4.2	Fire Command Station Fire Alarm System Functions.....	44
4.3	Fire Alarm System Functions.....	44
4.4	Fire Alarm System Installation Criteria.....	45
Chapter 5		
Fire Alarm System Design, Equipment, Installation, and Performance Criteria.....		47
5.1	System Design and Installation Criteria for WTC 1 and WTC 2.....	48
5.1.1	System Arrangement.....	48
5.1.2	Design Criteria.....	49

5.1.3	Speaker Audibility and Intelligibility	49
5.1.4	Design Guidelines	50
5.1.5	Design Approach	51
5.1.6	Typical Fire Alarm Equipment and Device Locations	53
5.1.7	Typical Fire Alarm Cabinet Connections	53
5.1.8	Typical Fire Alarm Installation Detail	56
5.1.9	Typical Fire Alarm Circuit Routing Criteria	58
5.1.10	Typical Fire Alarm Device Design Detail	58
5.1.11	Typical Fire Alarm Device Riser Detail	62
5.1.12	Installation Acceptance Testing and Commissioning Procedures	63
5.1.13	Quality and Performance Assurance Forms	64
5.1.14	Fire Command Station Performance Standard	66
5.1.15	Fire Command Station Equipment	66
5.1.16	Fire Command Station Design, Installation, and Operation	68
5.2	Base Building Fire Alarm Equipment Performance Standard	69
5.2.1	Base Building Fire Alarm System Equipment	69
5.2.2	Base Building Fire Alarm System Design, Installation, and Operation	74
5.3	System Network Transmission Paths Performance Standards	74
5.3.1	Detection, Monitoring, and Control Network Transmission Path Performance	75
5.3.2	Detection, Monitoring, and Control Network Transmission Path Design, Installation, and Control	77
5.3.3	Typical Detection, Monitoring, and Control Devices	84
5.3.4	Typical Detection, Monitoring, and Control Device Design and Installation	84
5.3.5	Notification Appliance Circuit Network Transmission Path Performance	86
5.3.6	Notification Appliance Circuit Network Transmission Path Design, Installation, and Control	87
5.3.7	Typical Speaker Notification Appliance Devices	90
5.3.8	Typical Strobe Notification Appliance Devices	91
5.3.9	Typical Strobe Circuits Equipment and Installation	92
5.3.10	Floor Warden and Fireman Telephone Network Transmission Paths	92
5.3.11	Floor Warden and Fireman Telephone Network Transmission Path Design, Installation, and Control	93
5.3.12	Typical Floor Warden and Fireman Telephone Devices	96
5.3.13	Floor Warden and Fireman Telephone Station System Design and Installation	96
5.4	Maintenance Performance Standard	97
5.5	System Design and Installation Criteria for WTC 7	97

5.5.1	System Arrangement	98
5.5.2	Design Approach	98
5.5.3	Typical Fire Alarm Equipment and Device Locations	99
5.5.4	Typical Fire Alarm Cabinet Connections	99
5.5.5	Typical Fire Alarm Installation Detail	99
5.5.6	Fire Alarm Device Design Detail	99
5.5.7	Fire Alarm Power Calculations	100
5.5.8	Quality and Performance Assurance Forms	100
5.5.9	Installation Acceptance Testing and Commissioning Procedures	100
5.5.10	Inspection, Testing, and Maintenance	100
5.6	Comparison of WTC 7 Fire Alarm System to WTC 1 and WTC 2 Fire Alarm System.....	100
Chapter 6		
Estimates of Performance of the Fire Alarm System on September 11, 2001		103
6.1	Analysis Development	103
6.2	Observations	103
6.2.1	Summary of Results	106
Chapter 7		
References.....		109

LIST OF FIGURES

Figure P-1.	The eight projects in the federal building and fire safety investigation of the WTC disaster.	xix
Figure 1-1.	WTC complex.	3
Figure 1-2.	Phase I backbone.	5
Figure 1-3.	Phase II transition.	6
Figure 3-1.	Typical break-glass station.	16
Figure 3-2.	Interior of break-glass station.	17
Figure 3-3.	Break-glass station.	18
Figure 3-4.	Fire alarm console.	19
Figure 3-5.	Fire alarm console (Zones 1, 2, 3, 8, 10).	21
Figure 3-6.	Typical interior return air smoke detector (ceiling tile removed).	22
Figure 3-7.	Elevator lobby smoke detector.	23
Figure 3-8.	Typical supply air duct detector installation.	24
Figure 3-9.	Typical return air duct and duct detector.	25
Figure 3-10.	Typical pendant mounted smoke detector.	26
Figure 3-11.	Horn type speaker in a stairway enclosure.	28
Figure 3-12.	Recessed speaker in corridor.	29
Figure 3-13.	Control center console police desk Level B1.	30
Figure 3-14.	Public address console.	31
Figure 3-15.	Sprinkler waterflow detector installation.	32
Figure 3-16.	Sprinkler alarm annunciator in HVAC computer room.	33
Figure 3-17.	Outlying station interior view.	34
Figure 3-18.	Outlying station of Standpipe Fireline Communication System.	35
Figure 5-1.	Speaker intelligibility and audibility performance drawing.	50
Figure 5-2.	Core and quadrants.	52
Figure 5-3.	Standard locations for fire alarm equipment and devices.	53
Figure 5-4.	Standard configuration for Terminal Strip Cabinet.	54
Figure 5-5.	Standard configuration for Terminal Strip Cabinet.	55
Figure 5-6.	Standard location for fire alarm devices.	56

Figure 5–7. Standard locations for fire alarm duct smoke detectors. 57

Figure 5–8. Standard routing for fire alarm circuit. 58

Figure 5–9. Standard layout for fire alarm detection..... 59

Figure 5–10. Standard layout for fire alarm speakers. 60

Figure 5–11. Standard layout for fire alarm strobes..... 61

Figure 5–12. Standard detail for fire alarm riser. 62

Figure 5–13. New work acceptance best practices..... 63

Figure 5–14. Contractor tie-in and pre-test checklist. 64

Figure 5–15. Contractor tie-in and pre-test checklist. 65

Figure 5–16. WTC 1 fire command station..... 67

Figure 5–17. WTC 2 fire command station..... 68

Figure 5–18. Mechanical equipment room (MER) MXL-VR location..... 70

Figure 5–19. Fire alarm closet with PSR location..... 72

Figure 5–20. Fire alarm closet with PSR location..... 73

Figure 5–21. Single-line schematic of MNET network configuration..... 78

Figure 5–22. Locations of typical MNET network equipment. 79

Figure 5–23. Single-line schematic of XNET network configuration..... 80

Figure 5–24. Locations of XNET network equipment..... 81

Figure 5–25. Operation Control Center located on the B1 Level below WTC 2 with redundant fire alarm system controls..... 82

Figure 5–26. Typical detection, monitoring, and control device layout..... 85

Figure 5–27. Single-line schematic of notification appliance network. 88

Figure 5–28. Locations of audible notification appliance network equipment. 89

Figure 5–29. Speaker circuit configurations. 91

Figure 5–30. Strobe circuit configurations..... 92

Figure 5–31. Single-line schematic of floor warden and firefighter telephones. 94

Figure 5–32. Locations floor warden and firefighter telephone network equipment. 95

Figure 6–1. WTC 2 speaker and telephone circuit faults. 105

Figure 6–2. WTC 7 central station alarm log. 107

LIST OF TABLES

Table P-1.	Federal building and fire safety investigation of the WTC disaster.....	xviii
Table P-2.	Public meetings and briefings of the WTC Investigation.	xxi
Table 5-1.	Performance of Signaling Line Circuits (SLC).....	76
Table 5-2.	Notification Appliance Circuits (NAC).	86

This page intentionally left blank.

LIST OF ACRONYMS AND ABBREVIATIONS

Acronyms

ADAAG	Americans with Disabilities Act Accessibility Guidelines for Building and Facilities
ANSI	American National Standards Institute
ASTM	ASTM International
ATC	ALD Terminal Cabinets
BBFAS	Base Building Fire Alarm System
BCNYC	Building Code of the City of New York
BPS	Building Performance Study
ESP	Elevator Starter Panel
EVAC	emergency voice alarm communication
FCS	Fire Command Station
FDNY	Fire Department of the City of New York
FEMA	Federal Emergency Management Agency
HVAC	heating, ventilating, and air conditioning
MER	Mechanical Equipment Room
NCC	Network Command Center
NFAC	National Fire Alarm Code
NFPA	National Fire Protection Association
NIST	National Institute of Standards and Technology
NYC	New York City
OCC	Operation Control Center
PA	Public Address System
PANYNJ	Port Authority of New York and New Jersey
PSR	Pyrotronics Remote Transponder
RMT	Remote Monitoring Transponders
SEAoNY	Structural Engineers Association of New York
TSC	Terminal Strip Cabinet
USC	United States Code
WTC	World Trade Center

WTC 1	World Trade Center 1 (North Tower)
WTC 2	World Trade Center 2 (South Tower)
WTC 7	World Trade Center 7

Abbreviations

°C	degrees Celsius
°F	degrees Fahrenheit
cfm	cubic feet per minute
ft	foot
h	hour
in.	inch
L	liter
m	meter
µm	micrometer
min	minute
s	second
V	volt
W	watt

GLOSSARY

Active fire protection – A means to help prevent the loss of life and property from fire by extinguishing, suppressing or controlling a fire through functional systems. Sprinkler systems, fire alarm systems and smoke control systems are examples of active fire protection.

Area of refuge – A floor area to which egress is made through a horizontal exit or supplemental vertical exit.

Combustible – A material that will ignite and burn when subjected to fire or heat.

Damper – A device installed in HVAC ductwork used to prevent the spread of fire and/or smoke. Dampers are provided to maintain a fire resistance rating of the assembly being penetrated.

Detector – An initiation device that automatically detects a change in state, such as presence of smoke, high temperature or abnormal rate of temperature rise.

Fire alarm system – A system, automatic or manual, arranged to give a signal indicating a fire emergency and initiate the appropriate response.

Fire resistance rating – The time in hours that materials or their assemblies will withstand fire exposure as determined by a fire test.

Fireproofing – A method used to provide a fire resistance rating to a building component.

Firestopping – A solid or compact, tight closure to retard the spread of flames or hot gases within concealed spaces.

Initiation device – A system component that originates a change in state signal in the fire alarm system. An initiation device begins the life safety processes, such as evacuation, HVAC shut down, elevator recall, etc.

Manual fire alarm box – A manually operated initiation device that originates a change in state signal in the fire alarm system.

Means of egress – A continuous and unobstructed path of vertical and horizontal travel from any point in a building to a public way. The means of egress consists of: the exit access, the exit and the exit discharge.

Noncombustible – A material that does not ignite or burn when subjected to fire and heat.

Notification appliance – A fire alarm system component such as a bell, horn, speaker, or strobe that provides audible, tactile, or visible outputs, or any combination thereof.

Passive fire protection – A means to help prevent the loss of life and property from fire by increasing the time to ignition or time to failure of a material. Providing fire separations and divisions, applying sprayed fire-resistive material and enclosing structural members with noncombustible materials are examples of passive fire protection.

Smoke and heat venting – A process used to move products of combustion to the outdoor air.

PREFACE

Genesis of This Investigation

Immediately following the terrorist attack on the World Trade Center (WTC) on September 11, 2001, the Federal Emergency Management Agency (FEMA) and the American Society of Civil Engineers began planning a building performance study of the disaster. The week of October 7, as soon as the rescue and search efforts ceased, the Building Performance Study Team went to the site and began its assessment. This was to be a brief effort, as the study team consisted of experts who largely volunteered their time away from their other professional commitments. The Building Performance Study Team issued its report in May 2002, fulfilling its goal “to determine probable failure mechanisms and to identify areas of future investigation that could lead to practical measures for improving the damage resistance of buildings against such unforeseen events.”

On August 21, 2002, with funding from the U.S. Congress through FEMA, the National Institute of Standards and Technology (NIST) announced its building and fire safety investigation of the WTC disaster. On October 1, 2002, the National Construction Safety Team Act (Public Law 107-231), was signed into law. The NIST WTC Investigation was conducted under the authority of the National Construction Safety Team Act.

The goals of the investigation of the WTC disaster were:

- To investigate the building construction, the materials used, and the technical conditions that contributed to the outcome of the WTC disaster.
- To serve as the basis for:
 - Improvements in the way buildings are designed, constructed, maintained, and used;
 - Improved tools and guidance for industry and safety officials;
 - Recommended revisions to current codes, standards, and practices; and
 - Improved public safety.

The specific objectives were:

1. Determine why and how WTC 1 and WTC 2 collapsed following the initial impacts of the aircraft and why and how WTC 7 collapsed;
2. Determine why the injuries and fatalities were so high or low depending on location, including all technical aspects of fire protection, occupant behavior, evacuation, and emergency response;
3. Determine what procedures and practices were used in the design, construction, operation, and maintenance of WTC 1, 2, and 7; and
4. Identify, as specifically as possible, areas in current building and fire codes, standards, and practices that warrant revision.

NIST is a nonregulatory agency of the U.S. Department of Commerce’s Technology Administration. The purpose of NIST investigations is to improve the safety and structural integrity of buildings in the United States, and the focus is on fact finding. NIST investigative teams are authorized to assess building performance and emergency response and evacuation procedures in the wake of any building failure that has resulted in substantial loss of life or that posed significant potential of substantial loss of life. NIST does not have the statutory authority to make findings of fault nor negligence by individuals or organizations. Further, no part of any report resulting from a NIST investigation into a building failure or from an investigation under the National Construction Safety Team Act may be used in any suit or action for damages arising out of any matter mentioned in such report (15 USC 281a, as amended by Public Law 107-231).

Organization of the Investigation

The National Construction Safety Team for this Investigation, appointed by the then NIST Director, Dr. Arden L. Bement, Jr., was led by Dr. S. Shyam Sunder. Dr. William L. Grosshandler served as Associate Lead Investigator, Mr. Stephen A. Cauffman served as Program Manager for Administration, and Mr. Harold E. Nelson served on the team as a private sector expert. The Investigation included eight interdependent projects whose leaders comprised the remainder of the team. A detailed description of each of these eight projects is available at <http://wtc.nist.gov>. The purpose of each project is summarized in Table P–1, and the key interdependencies among the projects are illustrated in Fig. P–1.

Table P–1. Federal building and fire safety investigation of the WTC disaster.

Technical Area and Project Leader	Project Purpose
Analysis of Building and Fire Codes and Practices; Project Leaders: Dr. H. S. Lew and Mr. Richard W. Bukowski	Document and analyze the code provisions, procedures, and practices used in the design, construction, operation, and maintenance of the structural, passive fire protection, and emergency access and evacuation systems of WTC 1, 2, and 7.
Baseline Structural Performance and Aircraft Impact Damage Analysis; Project Leader: Dr. Fahim H. Sadek	Analyze the baseline performance of WTC 1 and WTC 2 under design, service, and abnormal loads, and aircraft impact damage on the structural, fire protection, and egress systems.
Mechanical and Metallurgical Analysis of Structural Steel; Project Leader: Dr. Frank W. Gayle	Determine and analyze the mechanical and metallurgical properties and quality of steel, weldments, and connections from steel recovered from WTC 1, 2, and 7.
Investigation of Active Fire Protection Systems; Project Leader: Dr. David D. Evans; Dr. William Grosshandler	Investigate the performance of the active fire protection systems in WTC 1, 2, and 7 and their role in fire control, emergency response, and fate of occupants and responders.
Reconstruction of Thermal and Tenability Environment; Project Leader: Dr. Richard G. Gann	Reconstruct the time-evolving temperature, thermal environment, and smoke movement in WTC 1, 2, and 7 for use in evaluating the structural performance of the buildings and behavior and fate of occupants and responders.
Structural Fire Response and Collapse Analysis; Project Leaders: Dr. John L. Gross and Dr. Therese P. McAllister	Analyze the response of the WTC towers to fires with and without aircraft damage, the response of WTC 7 in fires, the performance of composite steel-trussed floor systems, and determine the most probable structural collapse sequence for WTC 1, 2, and 7.
Occupant Behavior, Egress, and Emergency Communications; Project Leader: Mr. Jason D. Averill	Analyze the behavior and fate of occupants and responders, both those who survived and those who did not, and the performance of the evacuation system.
Emergency Response Technologies and Guidelines; Project Leader: Mr. J. Randall Lawson	Document the activities of the emergency responders from the time of the terrorist attacks on WTC 1 and WTC 2 until the collapse of WTC 7, including practices followed and technologies used.

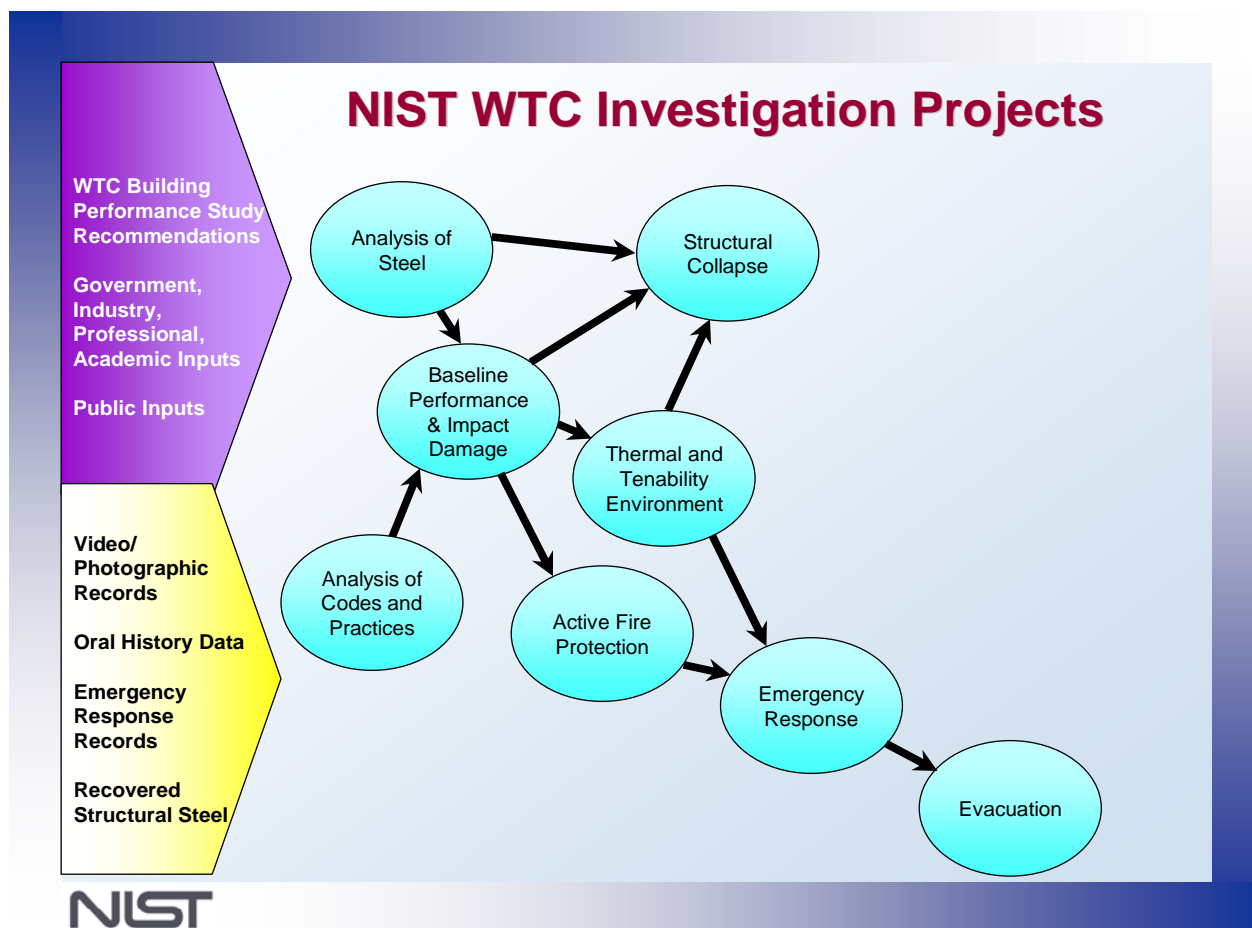

Figure P–1. The eight projects in the federal building and fire safety investigation of the WTC disaster.

National Construction Safety Team Advisory Committee

The NIST Director also established an advisory committee as mandated under the National Construction Safety Team Act. The initial members of the committee were appointed following a public solicitation. These were:

- Paul Fitzgerald, Executive Vice President (retired) FM Global, National Construction Safety Team Advisory Committee Chair
- John Barsom, President, Barsom Consulting, Ltd.
- John Bryan, Professor Emeritus, University of Maryland
- David Collins, President, The Preview Group, Inc.
- Glenn Corbett, Professor, John Jay College of Criminal Justice
- Philip DiNunno, President, Hughes Associates, Inc.

- Robert Hanson, Professor Emeritus, University of Michigan
- Charles Thornton, Co-Chairman and Managing Principal, The Thornton-Tomasetti Group, Inc.
- Kathleen Tierney, Director, Natural Hazards Research and Applications Information Center, University of Colorado at Boulder
- Forman Williams, Director, Center for Energy Research, University of California at San Diego

This National Construction Safety Team Advisory Committee provided technical advice during the Investigation and commentary on drafts of the Investigation reports prior to their public release. NIST has benefited from the work of many people in the preparation of these reports, including the National Construction Safety Team Advisory Committee. The content of the reports and recommendations, however, are solely the responsibility of NIST.

Public Outreach

During the course of this Investigation, NIST held public briefings and meetings (listed in Table P-2) to solicit input from the public, present preliminary findings, and obtain comments on the direction and progress of the Investigation from the public and the Advisory Committee.

NIST maintained a publicly accessible Web site during this Investigation at <http://wtc.nist.gov>. The site contained extensive information on the background and progress of the Investigation.

NIST's WTC Public-Private Response Plan

The collapse of the WTC buildings has led to broad reexamination of how tall buildings are designed, constructed, maintained, and used, especially with regard to major events such as fires, natural disasters, and terrorist attacks. Reflecting the enhanced interest in effecting necessary change, NIST, with support from Congress and the Administration, has put in place a program, the goal of which is to develop and implement the standards, technology, and practices needed for cost-effective improvements to the safety and security of buildings and building occupants, including evacuation, emergency response procedures, and threat mitigation.

The strategy to meet this goal is a three-part NIST-led public-private response program that includes:

- A federal building and fire safety investigation to study the most probable factors that contributed to post-aircraft impact collapse of the WTC towers and the 47-story WTC 7 building, and the associated evacuation and emergency response experience.
- A research and development (R&D) program to (a) facilitate the implementation of recommendations resulting from the WTC Investigation, and (b) provide the technical basis for cost-effective improvements to national building and fire codes, standards, and practices that enhance the safety of buildings, their occupants, and emergency responders.

Table P-2. Public meetings and briefings of the WTC Investigation.

Date	Location	Principal Agenda
June 24, 2002	New York City, NY	Public meeting: Public comments on the <i>Draft Plan</i> for the pending WTC Investigation.
August 21, 2002	Gaithersburg, MD	Media briefing announcing the formal start of the Investigation.
December 9, 2002	Washington, DC	Media briefing on release of the <i>Public Update</i> and NIST request for photographs and videos.
April 8, 2003	New York City, NY	Joint public forum with Columbia University on first-person interviews.
April 29–30, 2003	Gaithersburg, MD	NCST Advisory Committee meeting on plan for and progress on WTC Investigation with a public comment session.
May 7, 2003	New York City, NY	Media briefing on release of <i>May 2003 Progress Report</i> .
August 26–27, 2003	Gaithersburg, MD	NCST Advisory Committee meeting on status of the WTC investigation with a public comment session.
September 17, 2003	New York City, NY	Media and public briefing on initiation of first-person data collection projects.
December 2–3, 2003	Gaithersburg, MD	NCST Advisory Committee meeting on status and initial results and release of the <i>Public Update</i> with a public comment session.
February 12, 2004	New York City, NY	Public meeting on progress and preliminary findings with public comments on issues to be considered in formulating final recommendations.
June 18, 2004	New York City, NY	Media/public briefing on release of <i>June 2004 Progress Report</i> .
June 22–23, 2004	Gaithersburg, MD	NCST Advisory Committee meeting on the status of and preliminary findings from the WTC Investigation with a public comment session.
August 24, 2004	Northbrook, IL	Public viewing of standard fire resistance test of WTC floor system at Underwriters Laboratories, Inc.
October 19–20, 2004	Gaithersburg, MD	NCST Advisory Committee meeting on status and near complete set of preliminary findings with a public comment session.
November 22, 2004	Gaithersburg, MD	NCST Advisory Committee discussion on draft annual report to Congress, a public comment session, and a closed session to discuss pre-draft recommendations for WTC Investigation.
April 5, 2005	New York City, NY	Media and public briefing on release of the probable collapse sequence for the WTC towers and draft reports for the projects on codes and practices, evacuation, and emergency response.
June 23, 2005	New York City, NY	Media and public briefing on release of all draft reports for the WTC towers and draft recommendations for public comment.
September 12–13, 2005	Gaithersburg, MD	NCST Advisory Committee meeting on disposition of public comments and update to draft reports for the WTC towers.
September 13–15, 2005	Gaithersburg, MD	WTC Technical Conference for stakeholders and technical community for dissemination of findings and recommendations and opportunity for public to make technical comments.

- A dissemination and technical assistance program (DTAP) to (a) engage leaders of the construction and building community in ensuring timely adoption and widespread use of proposed changes to practices, standards, and codes resulting from the WTC Investigation and the R&D program, and (b) provide practical guidance and tools to better prepare facility owners, contractors, architects, engineers, emergency responders, and regulatory authorities to respond to future disasters.

The desired outcomes are to make buildings, occupants, and first responders safer in future disaster events.

National Construction Safety Team Reports on the WTC Investigation

A final report on the collapse of the WTC towers is being issued as NIST NCSTAR 1. A companion report on the collapse of WTC 7 is being issued as NIST NCSTAR 1A. The present report is one of a set that provides more detailed documentation of the Investigation findings and the means by which these technical results were achieved. As such, it is part of the archival record of this Investigation. The titles of the full set of Investigation publications are:

NIST (National Institute of Standards and Technology). 2005. *Federal Building and Fire Safety Investigation of the World Trade Center Disaster: Final Report on the Collapse of the World Trade Center Towers*. NIST NCSTAR 1. Gaithersburg, MD, September.

NIST (National Institute of Standards and Technology). 2008. *Federal Building and Fire Safety Investigation of the World Trade Center Disaster: Final Report on the Collapse of World Trade Center 7*. NIST NCSTAR 1A. Gaithersburg, MD, November.

Lew, H. S., R. W. Bukowski, and N. J. Carino. 2005. *Federal Building and Fire Safety Investigation of the World Trade Center Disaster: Design, Construction, and Maintenance of Structural and Life Safety Systems*. NIST NCSTAR 1-1. National Institute of Standards and Technology. Gaithersburg, MD, September.

Fanella, D. A., A. T. Derecho, and S. K. Ghosh. 2005. *Federal Building and Fire Safety Investigation of the World Trade Center Disaster: Design and Construction of Structural Systems*. NIST NCSTAR 1-1A. National Institute of Standards and Technology. Gaithersburg, MD, September.

Ghosh, S. K., and X. Liang. 2005. *Federal Building and Fire Safety Investigation of the World Trade Center Disaster: Comparison of Building Code Structural Requirements*. NIST NCSTAR 1-1B. National Institute of Standards and Technology. Gaithersburg, MD, September.

Fanella, D. A., A. T. Derecho, and S. K. Ghosh. 2005. *Federal Building and Fire Safety Investigation of the World Trade Center Disaster: Maintenance and Modifications to Structural Systems*. NIST NCSTAR 1-1C. National Institute of Standards and Technology. Gaithersburg, MD, September.

Grill, R. A., and D. A. Johnson. 2005. *Federal Building and Fire Safety Investigation of the World Trade Center Disaster: Fire Protection and Life Safety Provisions Applied to the Design and Construction of World Trade Center 1, 2, and 7 and Post-Construction Provisions Applied after Occupancy*. NIST NCSTAR 1-1D. National Institute of Standards and Technology. Gaithersburg, MD, September.

Razza, J. C., and R. A. Grill. 2005. *Federal Building and Fire Safety Investigation of the World Trade Center Disaster: Comparison of Codes, Standards, and Practices in Use at the Time of the Design and Construction of World Trade Center 1, 2, and 7*. NIST NCSTAR 1-1E. National Institute of Standards and Technology. Gaithersburg, MD, September.

Grill, R. A., D. A. Johnson, and D. A. Fanella. 2005. *Federal Building and Fire Safety Investigation of the World Trade Center Disaster: Comparison of the 1968 and Current (2003) New*

- York City Building Code Provisions*. NIST NCSTAR 1-1F. National Institute of Standards and Technology. Gaithersburg, MD, September.
- Grill, R. A., and D. A. Johnson. 2005. *Federal Building and Fire Safety Investigation of the World Trade Center Disaster: Amendments to the Fire Protection and Life Safety Provisions of the New York City Building Code by Local Laws Adopted While World Trade Center 1, 2, and 7 Were in Use*. NIST NCSTAR 1-1G. National Institute of Standards and Technology. Gaithersburg, MD, September.
- Grill, R. A., and D. A. Johnson. 2005. *Federal Building and Fire Safety Investigation of the World Trade Center Disaster: Post-Construction Modifications to Fire Protection and Life Safety Systems of World Trade Center 1 and 2*. NIST NCSTAR 1-1H. National Institute of Standards and Technology. Gaithersburg, MD, September.
- Grill, R. A., D. A. Johnson, and D. A. Fanella. 2005. *Federal Building and Fire Safety Investigation of the World Trade Center Disaster: Post-Construction Modifications to Fire Protection, Life Safety, and Structural Systems of World Trade Center 7*. NIST NCSTAR 1-1I. National Institute of Standards and Technology. Gaithersburg, MD, September.
- Grill, R. A., and D. A. Johnson. 2005. *Federal Building and Fire Safety Investigation of the World Trade Center Disaster: Design, Installation, and Operation of Fuel System for Emergency Power in World Trade Center 7*. NIST NCSTAR 1-1J. National Institute of Standards and Technology. Gaithersburg, MD, September.
- Sadek, F. 2005. *Federal Building and Fire Safety Investigation of the World Trade Center Disaster: Baseline Structural Performance and Aircraft Impact Damage Analysis of the World Trade Center Towers*. NIST NCSTAR 1-2. National Institute of Standards and Technology. Gaithersburg, MD, September.
- Faschan, W. J., and R. B. Garlock. 2005. *Federal Building and Fire Safety Investigation of the World Trade Center Disaster: Reference Structural Models and Baseline Performance Analysis of the World Trade Center Towers*. NIST NCSTAR 1-2A. National Institute of Standards and Technology. Gaithersburg, MD, September.
- Kirkpatrick, S. W., R. T. Bocchieri, F. Sadek, R. A. MacNeill, S. Holmes, B. D. Peterson, R. W. Cilke, C. Navarro. 2005. *Federal Building and Fire Safety Investigation of the World Trade Center Disaster: Analysis of Aircraft Impacts into the World Trade Center Towers*, NIST NCSTAR 1-2B. National Institute of Standards and Technology. Gaithersburg, MD, September.
- Gayle, F. W., R. J. Fields, W. E. Luecke, S. W. Banovic, T. Foecke, C. N. McCowan, T. A. Siewert, and J. D. McColskey. 2005. *Federal Building and Fire Safety Investigation of the World Trade Center Disaster: Mechanical and Metallurgical Analysis of Structural Steel*. NIST NCSTAR 1-3. National Institute of Standards and Technology. Gaithersburg, MD, September.
- Luecke, W. E., T. A. Siewert, and F. W. Gayle. 2005. *Federal Building and Fire Safety Investigation of the World Trade Center Disaster: Contemporaneous Structural Steel Specifications*. NIST Special Publication 1-3A. National Institute of Standards and Technology. Gaithersburg, MD, September.

Banovic, S. W. 2005. *Federal Building and Fire Safety Investigation of the World Trade Center Disaster: Steel Inventory and Identification*. NIST NCSTAR 1-3B. National Institute of Standards and Technology. Gaithersburg, MD, September.

Banovic, S. W., and T. Foecke. 2005. *Federal Building and Fire Safety Investigation of the World Trade Center Disaster: Damage and Failure Modes of Structural Steel Components*. NIST NCSTAR 1-3C. National Institute of Standards and Technology. Gaithersburg, MD, September.

Luecke, W. E., J. D. McColskey, C. N. McCowan, S. W. Banovic, R. J. Fields, T. Foecke, T. A. Siewert, and F. W. Gayle. 2005. *Federal Building and Fire Safety Investigation of the World Trade Center Disaster: Mechanical Properties of Structural Steels*. NIST NCSTAR 1-3D. National Institute of Standards and Technology. Gaithersburg, MD, September.

Banovic, S. W., C. N. McCowan, and W. E. Luecke. 2005. *Federal Building and Fire Safety Investigation of the World Trade Center Disaster: Physical Properties of Structural Steels*. NIST NCSTAR 1-3E. National Institute of Standards and Technology. Gaithersburg, MD, September.

Evans, D. D., R. D. Peacock, E. D. Kuligowski, W. S. Dols, and W. L. Grosshandler. 2005. *Federal Building and Fire Safety Investigation of the World Trade Center Disaster: Active Fire Protection Systems*. NIST NCSTAR 1-4. National Institute of Standards and Technology. Gaithersburg, MD, September.

Kuligowski, E. D., D. D. Evans, and R. D. Peacock. 2005. *Federal Building and Fire Safety Investigation of the World Trade Center Disaster: Post-Construction Fires Prior to September 11, 2001*. NIST NCSTAR 1-4A. National Institute of Standards and Technology. Gaithersburg, MD, September.

Hopkins, M., J. Schoenrock, and E. Budnick. 2005. *Federal Building and Fire Safety Investigation of the World Trade Center Disaster: Fire Suppression Systems*. NIST NCSTAR 1-4B. National Institute of Standards and Technology. Gaithersburg, MD, September.

Keough, R. J., and R. A. Grill. 2005. *Federal Building and Fire Safety Investigation of the World Trade Center Disaster: Fire Alarm Systems*. NIST NCSTAR 1-4C. National Institute of Standards and Technology. Gaithersburg, MD, September.

Ferreira, M. J., and S. M. Strege. 2005. *Federal Building and Fire Safety Investigation of the World Trade Center Disaster: Smoke Management Systems*. NIST NCSTAR 1-4D. National Institute of Standards and Technology. Gaithersburg, MD, September.

Gann, R. G., A. Hamins, K. B. McGrattan, G. W. Mulholland, H. E. Nelson, T. J. Ohlemiller, W. M. Pitts, and K. R. Prasad. 2005. *Federal Building and Fire Safety Investigation of the World Trade Center Disaster: Reconstruction of the Fires in the World Trade Center Towers*. NIST NCSTAR 1-5. National Institute of Standards and Technology. Gaithersburg, MD, September.

Pitts, W. M., K. M. Butler, and V. Junker. 2005. *Federal Building and Fire Safety Investigation of the World Trade Center Disaster: Visual Evidence, Damage Estimates, and Timeline Analysis*. NIST NCSTAR 1-5A. National Institute of Standards and Technology. Gaithersburg, MD, September.

- Hamins, A., A. Maranghides, K. B. McGrattan, E. Johnsson, T. J. Ohlemiller, M. Donnelly, J. Yang, G. Mulholland, K. R. Prasad, S. Kukuck, R. Anleitner and T. McAllister. 2005. *Federal Building and Fire Safety Investigation of the World Trade Center Disaster: Experiments and Modeling of Structural Steel Elements Exposed to Fire*. NIST NCSTAR 1-5B. National Institute of Standards and Technology. Gaithersburg, MD, September.
- Ohlemiller, T. J., G. W. Mulholland, A. Maranghides, J. J. Filliben, and R. G. Gann. 2005. *Federal Building and Fire Safety Investigation of the World Trade Center Disaster: Fire Tests of Single Office Workstations*. NIST NCSTAR 1-5C. National Institute of Standards and Technology. Gaithersburg, MD, September.
- Gann, R. G., M. A. Riley, J. M. Repp, A. S. Whittaker, A. M. Reinhorn, and P. A. Hough. 2005. *Federal Building and Fire Safety Investigation of the World Trade Center Disaster: Reaction of Ceiling Tile Systems to Shocks*. NIST NCSTAR 1-5D. National Institute of Standards and Technology. Gaithersburg, MD, September.
- Hamins, A., A. Maranghides, K. B. McGrattan, T. J. Ohlemiller, and R. Anleitner. 2005. *Federal Building and Fire Safety Investigation of the World Trade Center Disaster: Experiments and Modeling of Multiple Workstations Burning in a Compartment*. NIST NCSTAR 1-5E. National Institute of Standards and Technology. Gaithersburg, MD, September.
- McGrattan, K. B., C. Bouldin, and G. Forney. 2005. *Federal Building and Fire Safety Investigation of the World Trade Center Disaster: Computer Simulation of the Fires in the World Trade Center Towers*. NIST NCSTAR 1-5F. National Institute of Standards and Technology. Gaithersburg, MD, September.
- Prasad, K. R., and H. R. Baum. 2005. *Federal Building and Fire Safety Investigation of the World Trade Center Disaster: Fire Structure Interface and Thermal Response of the World Trade Center Towers*. NIST NCSTAR 1-5G. National Institute of Standards and Technology. Gaithersburg, MD, September.
- Gross, J. L., and T. McAllister. 2005. *Federal Building and Fire Safety Investigation of the World Trade Center Disaster: Structural Fire Response and Probable Collapse Sequence of the World Trade Center Towers*. NIST NCSTAR 1-6. National Institute of Standards and Technology. Gaithersburg, MD, September.
- Carino, N. J., M. A. Starnes, J. L. Gross, J. C. Yang, S. Kukuck, K. R. Prasad, and R. W. Bukowski. 2005. *Federal Building and Fire Safety Investigation of the World Trade Center Disaster: Passive Fire Protection*. NIST NCSTAR 1-6A. National Institute of Standards and Technology. Gaithersburg, MD, September.
- Gross, J., F. Hervey, M. Izydorek, J. Mammoser, and J. Treadway. 2005. *Federal Building and Fire Safety Investigation of the World Trade Center Disaster: Fire Resistance Tests of Floor Truss Systems*. NIST NCSTAR 1-6B. National Institute of Standards and Technology. Gaithersburg, MD, September.
- Zarghamee, M. S., S. Bolourchi, D. W. Eggers, Ö. O. Erbay, F. W. Kan, Y. Kitane, A. A. Liepins, M. Mudlock, W. I. Naguib, R. P. Ojdrovic, A. T. Sarawit, P. R. Barrett, J. L. Gross, and

T. P. McAllister. 2005. *Federal Building and Fire Safety Investigation of the World Trade Center Disaster: Component, Connection, and Subsystem Structural Analysis*. NIST NCSTAR 1-6C. National Institute of Standards and Technology. Gaithersburg, MD, September.

Zarghamee, M. S., Y. Kitane, Ö. O. Erbay, T. P. McAllister, and J. L. Gross. 2005. *Federal Building and Fire Safety Investigation of the World Trade Center Disaster: Global Structural Analysis of the Response of the World Trade Center Towers to Impact Damage and Fire*. NIST NCSTAR 1-6D. National Institute of Standards and Technology. Gaithersburg, MD, September.

Averill, J. D., D. S. Mileti, R. D. Peacock, E. D. Kuligowski, N. Groner, G. Proulx, P. A. Reneke, and H. E. Nelson. 2005. *Federal Building and Fire Safety Investigation of the World Trade Center Disaster: Occupant Behavior, Egress, and Emergency Communication*. NIST NCSTAR 1-7. National Institute of Standards and Technology. Gaithersburg, MD, September.

Fahy, R., and G. Proulx. 2005. *Federal Building and Fire Safety Investigation of the World Trade Center Disaster: Analysis of Published Accounts of the World Trade Center Evacuation*. NIST NCSTAR 1-7A. National Institute of Standards and Technology. Gaithersburg, MD, September.

Zmud, J. 2005. *Federal Building and Fire Safety Investigation of the World Trade Center Disaster: Technical Documentation for Survey Administration*. NIST NCSTAR 1-7B. National Institute of Standards and Technology. Gaithersburg, MD, September.

Lawson, J. R., and R. L. Vettori. 2005. *Federal Building and Fire Safety Investigation of the World Trade Center Disaster: The Emergency Response Operations*. NIST NCSTAR 1-8. National Institute of Standards and Technology. Gaithersburg, MD, September.

McAllister, T., R. G. Gann, J. D. Averill, J. L. Gross, W. L. Grosshandler, J. R. Lawson, K. B. McGrattan, H. E. Nelson, W. M. Pitts, K. R. Prasad, F. H. Sadek. 2008. *Federal Building and Fire Safety Investigation of the World Trade Center Disaster: Structural Fire Response and Probable Collapse Sequence of World Trade Center Building 7*. NIST NCSTAR 1-9. National Institute of Standards and Technology. Gaithersburg, MD, November.

MacNeill, R., S. Kirkpatrick, B. Peterson, and R. Bocchieri. 2008. *Federal Building and Fire Safety Investigation of the World Trade Center Disaster: Global Structural Analysis of the Response of World Trade Center Building 7 to Fires and Debris Impact Damage*. NIST NCSTAR 1-9A. National Institute of Standards and Technology. Gaithersburg, MD, November.

EXECUTIVE SUMMARY

E.1 FIRE ALARM HISTORY AND APPLICATION

The application, performance, and use of fire alarms have changed over time through the development of technology, and the public's expectation for fire safe buildings. The goal of the early systems was to enhance property protection through early notification of first responders to initiate human intervention that would limit property damage. Although life saving acts were performed by first responders, the intent of the first fire alarm systems was to summon first responders to the fire, not to notify building occupants of an impending fire emergency.

It wasn't until major studies published in 1962 by Mc Guire and Ruscoe and the Federal Fire Council ("Needed—Protection for People") that it was recognized that the majority of fire protection devices in the market were devoted to property protection, not life safety enhancement. This realization has led to the development of a more holistic approach to fire protection that includes the fire alarm as one of numerous building systems involved in both occupant life safety and property protection.

The role played by a fire alarm system in the overall fire protection goals of a building is usually guided by codes and standards adopted for the project, or enforced within the jurisdiction of the project. As an interstate compact under the U.S. Constitution, the Port Authority was not subjected to any state or local building codes. The Building Code of the City of New York (BCNYC) provides the criteria for the type, location, and installation requirements for fire alarm protection within buildings in the City of New York. The code has adopted sections, but not the full content of the National Fire Alarm Code and National Electrical Code, as a Reference Standard (RS 17-3) for the installation of fire alarm systems. As in the case of model building codes, the BCNYC has referenced specific editions of the supporting codes and standards, such as the National Fire Alarm Code and National Electrical Code, which are not the most current editions published. This is due to the fact that standards are constantly undergoing revision to address new technologies and to incorporate issues identified during application of the standards. Also, a code or standard that is in effect when a system is designed is usually applied to the system during its existence, even if new codes or standards are developed or adopted by the authority having jurisdiction during the time between when the project was approved and when it is completed. As such, the most recent codes and standards are usually not applicable to a project due to the lag time between code or standard development and its adoption by an authority having jurisdiction over any project.

E.2 WORLD TRADE CENTER (WTC) 1, 2, AND 7 FIRE ALARM INTRODUCTION

The successful function and operation of a fire alarm system is dependent on its design, equipment, installation, maintenance, and on its use during an emergency. The majority of the documentation of the fire alarm systems in WTC 1 and WTC 2 were kept on the 81st floor of WTC 1, which served as the fire alarm contractor's office. This material was lost with the towers. Limited documentation maintained off-site, along with information gained from personnel involved with the systems, allowed for the re-creation of the system's design development, intended functions, and installation architecture. Actual documentation and personal experiences relevant to the systems function and use during the events of

September 11, 2001 are sporadic in detail, with very limited documentation on the actual use or functional interaction with the building occupants and other life safety systems.

The documentation and personal experiences relating to the WTC 7 system were limited, and only paint a partial picture of its equipment and architecture. Maintenance documentation was available, showing that the system was tested on a regular basis, but there was no documentation available on its design development, installation, or use. The information on the performance of the fire alarm system on September 11, 2001, is limited to a printout reporting of the systems alarm condition to an off-site monitoring service.

E.3 NORMAL OPERATIONS AND FIRE EMERGENCY RESPONSE

The Port Authority of New York and New Jersey (PANYNJ or Port Authority) had a Fire Safety Plan for WTC 1, 2, and 7 that provided direction for fire emergency response and was organized around a hierarchy of staff associated with its implementation. At the top of this hierarchy was the WTC Fire Safety Director. The Fire Safety Director oversaw fire emergency response until the arrival of The Fire Department of the City of New York (FDNY or Fire Department), and was responsible for gathering all necessary information for the Fire Department, which he/she relayed to the Chief upon his/her arrival. In WTC 1 and WTC 2, subordinate to the Fire Safety Director was the Assistant Fire Safety Coordinator, who was responsible for the availability and state of readiness of the Fire Brigade and the entire Emergency Response Team (members of the WTC Division of the Port Authority Police, who receive firefighting training and staff the WTC Fire Brigade). In WTC 7, the Fire Safety Director also performed the functions of the Assistant Fire Safety Coordinator as identified above. WTC 7 also had a Fire Brigade that the Fire Safety Director was responsible for organizing and training.

In addition to the WTC 1 and WTC 2 Assistant Fire Safety Coordinator, the towers had an Emergency Response Team consisting of Deputy Fire Safety Directors, Lobby Deputy Fire Safety Directors, Floor Wardens and Deputy Floor Wardens. Deputy Fire Safety Directors were responsible for performing the duties of the Assistant Fire Safety Coordinator in his/her absence and staffing the Fire Command Station for the purposes of executing the fire safety plan. At the end of the hierarchical chain for WTC 1, 2, and 7 were Floor Wardens and Deputy Floor Wardens, who were responsible for assessing conditions and assisting in evacuation of floor occupants on their respective floors upon direction from the Fire Brigade and/or Fire Command Station. Floor Wardens, Deputy Floor Wardens, and their alternates were appointed tenants or employees of the WTC complex (SafirRosetti 2002; Kastner 1990; PANYNJ 2001).

Fire drills were conducted at WTC 1, 2, and 7 every six months under the direction of the Floor Warden and Deputies of the Floor Warden. During the drills all employees, occupants, and visitors of the floor where the drill was conducted were physically required to leave their office areas and evacuate to a central hallway, near a stairwell. In addition, regular training exercises were conducted by the Port Authority and the Fire Department, the designated lead authority responsible for command of fire incidents at the WTC complex. The exercises oriented new staff to the building, its equipment and the appropriate emergency response procedures and served as a reminder to existing staff in the Port Authority and New York City Fire Department.

Fire inspections were performed annually in each tenant space to limit the risk of life and property loss from fire. A written report was prepared for all fire inspections and was maintained by the Fire Safety

Office. Any deficiencies or violations were noted in the report and forwarded to the appropriate person in the tenant space for correction.

Upon discovery of fire or smoke, the Fire Safety Plan called for occupants to activate the nearest building manual fire alarm station, typically at the intersecting corridor, and to notify the WTC police via telephone. The Police Desk dispatched the Fire Brigade and verified transmission of the alarm to the New York City Fire Department. The Fire Safety Director could also initiate evacuation from the area or the entire building. In this situation, the fire alarm emergency voice communication system was activated on the floors to be evacuated. It is important to note that the transmission of the alarms to the building occupants in WTC 1 and WTC 2 was not automatic and required the Fire Safety Director's initiation. Tenant Fire Safety Procedures exercised during regular fire drills require that building occupants proceed to the corridor areas to wait for verbal instructions provided over the fire alarm emergency voice communication speakers.

E.4 ORIGINAL BUILDING FIRE ALARM SYSTEM

The WTC was designed in accordance with the New York City Building and Fire Prevention Codes of 1968, in effect at the time of the building's construction. The Port Authority of New York and New Jersey's objective was to adhere to or exceed local code requirements whenever practical.

In addition to legislated building codes, the Port Authority relied on nationally recognized fire safety standards published by the American National Standards Institute (ANSI) and the National Fire Protection Association (NFPA), as well as internal protocols established with fire officials in the city. Two noteworthy protocols included the "Protocol for Periodic Joint Port Authority/Fire Department of New York Inspections of Port Authority New York City Facilities" of 1988 and the "WTC/FDNY Joint Protocol for Inspectional Activity at the World Trade Center Complex" of 1986. The Port Authority maintained a working relationship with the New York City Fire Department through these protocols that allowed the Fire Department access for inspections and evaluation of life safety and fire protection systems at the complex. The Fire Department was provided with the authority to issue advisory reports resulting from their inspections, which the Port Authority could consider on a voluntary basis.

The fire alarm system originally installed within the WTC provided protection for the following facilities:

- WTC 1
- WTC 2
- WTC 4
- WTC 5
- Concourse Level
- Sub-Grade Level

The system integrated detectors and alarm devices from the various buildings, to be tied into a control panel for that building or level. All control panels simultaneously annunciated alarms and troubles at the Operations Control Center.

The system consisted of American Multiplex Remote Monitoring Transponders (RMT) on every third floor, connected to the Digital Computer and Console in the Operations Control Center on the B-1 Sub-Grade Level. Transponders monitored Pyrotronics CR-7 Equipment connected to type DI-2, DI-3, DI-4A, and DI-6 smoke detectors (non-addressable type), Pyrotronics System 3 panels, tenant proprietary systems, waterflow switches, tamper switches, and control contacts.

Pyrotronics XL3 smoke detector systems, with addressable type detectors, were installed in the mechanical equipment rooms of both WTC 1 and WTC 2 and connected via a CXL Communication Device to a console in the Operations Control Center.

Manual Pull Stations were wired to an existing Executone system, which alarmed directly to the Fire Department.

The Public Address Communication System with manually activated selection of floor was also located at the Operations Control Center. Alarms from these systems were called in to the Fire Department, manually, by the Port Authority Police on duty 24 hours a day at the Police Desk.

The American Multiplex Digital Computer and Console was a fire alarm and communication system engineered and built specifically for the WTC. Although it was state-of-the-art at the time of construction, fire protection technology had changed significantly in the decades since the original installation. Performance based codes and standards had consolidated the fire detection, monitoring, control, and communication systems that were originally separate systems into single integrated systems. The Port Authority did upgrade the mechanical equipment room (MER) fire alarm protection with the installation of a microprocessor controlled, addressable Pyrotronics XL3 system in each MER, which was monitored by a CXL Command Center monitored in the Operations Control Center. The XL3 fire alarm system was the predecessor to the Siemens Pyrotronics MXL-V system that was installed after the 1993 bombing.

E.5 POST-1993 FIRE ALARM

The magnitude, size, and scope of the WTC fire alarm retrofit project rivaled any effort performed by the fire protection industry. It was estimated that over 10,000 initiating devices (smoke detectors, manual pull stations, waterflow indicators, etc.), with 30,000 notification appliances (speakers and strobes), supported by over 700,000 ft of conduit and 5 million ft of wire were installed in the WTC as part of the fire alarm system retrofit project (PANYNJ 1998). Project development documentation found and analyzed was focused on the system's architecture and performance. No documentation was found that indicated cost was a factor in obtaining the WTC's fire protection goals.

Before the original fire alarm system operation was fully restored after the 1993 bombing, the Port Authority Engineering Department began to explore the WTC's fire detection and alarm system's goals and how to incorporate these goals into a replacement system. Based upon its findings, the PA Engineering Department initiated a fire alarm retrofit project, which was developed from the following objectives (PANYNJ 1998):

1. Identify the type and extent of fire detection, communication, notification, and monitoring capabilities required.
2. Select the fire alarm technology to support the size of the WTC complex (approximately 12,000,000 ft²), with the capability to interface with the existing fire alarm systems. All the equipment was required to be New York City approved, and was required to be readily available for initial purchase and spare parts.
3. Determine the size, type, and number of equipment, devices, and hardware needed for the fire alarm infrastructure. Identify location and space for the infrastructure.
4. Determine how to interface the new system with the existing fire alarm systems and their components.
5. Develop standards, guidelines, and specifications for the design of the retrofit fire alarm system.
6. Develop standards, guidelines, and specifications for the installation of the fire alarm system.
7. Institute maintenance procedures to ensure the availability and performance of the fire alarm system.

Although documentation of the decision-making processes or directives defining the WTC fire alarm protection goals were not located, the overall design development, installation, and maintenance of the system indicates that it was the intention of the Port Authority to meet or exceed all local code and American with Disabilities Act requirements as interpreted by the Chief Engineer of the WTC. If the Port Authority believed that it was in the best interest of the WTC and its tenants to vary from the code requirements due to operations and/or other features of the fire alarm system, the Port Authority would obtain agreement or approval from the Fire Department and/or The New York City Department of Buildings (Department of Buildings) as per the Memorandum of Understanding signed between the Port Authority and the Department of Buildings (Semah 1996).

E.6 SEPTEMBER 11, 2001 FIRE ALARM PERFORMANCE

The review of the WTC fire alarm system's performance September 11, 2001, indicated that the systems did work, but not all functionality survived the impacts of the airplanes. The analysis of the fire alarm system's performance has led to the following results:

- Remote monitoring of the WTC 7 fire alarm systems only provided a time and date of the alarm condition (see Fig. 6-1). Large, addressable systems provide detailed information on the type of alarm or fault condition, their location, and the date/time of the occurrence. The analysis of the WTC fire alarm system would have benefited if the information commonly processed within the protected property was also transmitted and stored off-site at the location where the system was monitored.
- The WTC 1 and WTC 2 fire alarm systems required manual activation of the alarm signal to notify building occupants. This signal was delayed by 12 min after the impact in WTC 1.

Fire alarm systems have the capability and are usually configured to initiate an alarm signal automatically upon alarm initiation. Means are available to notify building occupants at risk automatically by an alarm signal upon activation of the fire alarm system.

- There is a disparity in performance requirements for the different types of circuits common to a fire alarm system. As an example, a Class A Style 7 Signaling Line Circuit will continue to perform if the circuit experiences a short. A Class A Style Z Notification Appliance Circuit will not perform if it experiences a short. A Signaling Line Circuit may be required to turn on loudspeakers connected to a Notification Appliance Circuit. If an event were to cause a short on both circuits, then the Signaling Line Circuit would be able to turn on Notification Appliance Circuits serving the loudspeakers, but the Notification Appliance Circuits providing the voice message or alarm tone to the speakers would not perform. Since the primary intent is to broadcast from the loudspeakers through the Notification Appliance Circuits, it would be appropriate for the Notification Appliance Circuits to have the same performance requirements as the Signaling Line Circuits.
- The disparity in circuit performance is also relevant to the floor warden and standpipe fireline telephones. The fault tolerance performance standards for telephone communication circuits are not as well defined as compared to other types of fire alarm circuits. This limits the survivability characteristics of the telephone communication circuits in comparison to other types of fire alarm circuits. Although manufacturers commonly provide some survivability characteristics, there is not a standard requiring minimum circuit performance. As with the Notification Appliance Circuits, a Signaling Line Circuit with robust survivability from functional faults may be controlling the operation of a telephone circuit, which has minimal survivability capabilities. If a fire alarm system objective is to provide enhanced survivability characteristics through a Signaling Line Circuit that will control a required function such as a telephone, then it would be appropriate for the survivability performance characteristics of the circuits for the required function to match the performance of the circuit supporting the function.
- Although there is evidence that the floor warden telephones were used, the after action interviews of the firefighters conducted by the National Institute of Standards and Technology (NIST) did not find that there was any attempt to use the standpipe fireline telephone system. This is not uncommon since the firefighters are trained to use their radios as the preferred means of communication. The resources used to install a firefighter telephone system would appear to be better served by installing radio repeaters to support their radio communication instead of installing dedicated telephones.
- Although the fire alarm systems in WTC 1 and WTC 2 used multiple communication path risers, the systems experienced performance degradation, especially in WTC 1 where all fire alarm notification and communication functions appear to have been lost above the floors of impact. The use of multiple risers does improve physical survivability in tall buildings, but other measures may be necessary to address the extensive damage associated with a possible explosion. Additional fire alarm system survivability can be gained through the location of the fire alarm equipment and a riser in a central building core area, and by protecting the area with structural hardening and fire-resistive construction. Similar enhancements can be

achieved through the provision of additional fire alarm risers remotely located away from the central core, supported by structural members, and provided with fire-resistive protection.

This page intentionally left blank.

Chapter 1

INTRODUCTION

1.1 PURPOSE

The purpose of this report is to document the design, installation, and modifications to the fire detection and alarm system for buildings 1, 2, and 7 of the World Trade Center (WTC), including system performance during the September 11, 2001, attack.

1.2 HISTORY OF FIRE ALARM SYSTEMS

The application, performance, and use of fire alarms have changed over time through the development of technology, and the public's expectation for fire safe buildings. The history of fire alarms began in 1847, when the first municipal fire alarm system was installed in New York City. This first system consisted of a dedicated telegraph system connecting City Hall to outlying fire stations. The central monitoring and emergency force notification concept was improved upon in 1852, when Boston installed 40 fire alarm signaling boxes throughout the city that provided a localized signal directly to first responders. This technology was further enhanced through the installation of fire alarm telegraph stations within buildings willing to pay for the service. The goal of all of these systems was to enhance property protection through early notification and to initiate human intervention that would limit property damage. Although life saving acts were performed by first responders, the intent of the first fire alarm systems during this time was to summon first responders to the fire, not to notify building occupants of an impending fire emergency.

Technology development continued with the introduction of automatic heat detectors that were remotely monitored. These devices were introduced in New York City as a function of a fire alarm system in the 1870s. This was the beginning of automatic fire department notification by a fire alarm system without the need for human action. Again, the intent was to provide early fire department notification for property protection, not building occupant notification. Fire detection technology improvements continued with the introduction of smoke detection in the 1930s, which had limited success until the 1960s, when lower costs and simpler technology made the devices more attractive to the market place. But, again, the primary use of both heat and smoke detectors was to enhance property protection.

It wasn't until major studies published in 1962 by Mc Guire and Ruscoe and the Federal Fire Council ("Needed—Protection for People") that it was recognized that the majority of fire protection devices in the market were devoted to property protection, not life safety enhancement for people. This realization has led to the development of a more holistic approach to fire protection that includes the fire alarm as one of numerous building systems involved in occupant life safety and property protection.

The role played by a fire alarm system in the overall fire protection goals of a building is usually guided by codes and standards adopted for the project, or enforced within the jurisdiction of the project. The codes and standards adopted represent the minimum performance requirements for the fire alarm system, along with all other components, structures, and systems that make up a "building." The first fire alarm

signaling standard, “General Rules for the Installation of Wiring, and Apparatus for Automatic Fire Alarms, Hatch Closers, Sprinkler Alarms, and Other Automatic Alarm Systems and Their Auxiliaries” was published in 1899 by the National Fire Protection Association (NFPA). This standard was the first of numerous editions that preceded the “National Fire Alarm Code” (NFPA 72), which is the baseline standard universally used in the United States today for fire alarms. The document provides the performance requirements for fire alarm equipment and devices, but does not provide direction on where a system or its devices are required. In addition to this performance standard for the fire alarm equipment and devices, a separate code provides direction for the installation of the fire alarm’s cable (wire) and supporting hardware. The universal baseline code used in the United States for power cabling and hardware is the “National Electrical Code” (NFPA 70), which includes fire alarm requirements. The National Electrical Code does not provide direction on what devices or equipment to install, only how to install the supporting cable and hardware. The what, when, and where fire alarm system requirements for a building are defined by the building code for the jurisdiction having authority over the protected structure. The Building Code of the City of New York (BCNYC) provides the criteria for the type, location, and installation requirements for fire alarm protection within buildings in the City of New York. The code has adopted sections, but not the full content of the National Fire Alarm Code and National Electrical Code, as a Reference Standard (RS-3) for the installation of fire alarm systems. As with all model building codes, the BCNYC has referenced editions of the supporting codes and standards, such as the National Fire Alarm Code and National Electrical Code, which are not the latest editions. Also, a code or standard that is in effect when a system is designed is applied to the system during its existence, even if new codes or standards are developed or adopted by the authority having jurisdiction during the time between when the project was approved and when it is completed. As such, the most recent codes and standards unless they contain retroactive provisions are usually not applicable to a project due to the lag time between code or standard development and its adoption by an authority having jurisdiction over any project.

As an interstate compact under the U.S. Constitution, the Port Authority was not subjected to any state or local building codes. Still, the Port Authority of New York and New Jersey’s (PANYNJ’s or Port Authority’s) objective was to adhere to or exceed local code requirements whenever practical.

1.3 WTC 1, 2, AND 7 INTRODUCTION

Figure 1–1 shows the buildings in the WTC complex. The availability and volume of documented history outlining the development of the alarm systems for WTC 1 and WTC 2 was substantially greater than what was available for WTC 7. The information available for WTC 7 was limited to system specifications, basic installation criteria, design drawings, and maintenance records. As such, the documentation and analysis of the WTC 7 fire alarm system is based on the limited information available.

The history of the WTC 1 and WTC 2 fire alarm system is well documented considering the fact that the central repository of the system’s documentation was lost on September 11, 2001. The fire alarm system protecting the WTC towers was a direct result of February 26, 1993, when a bomb exploded in the B-2 underground parking level of the WTC virtually destroying all the WTC 1 and WTC 2 fire alarm signaling and communication entering the Operations Control Center (OCC). That event effectively made the fire alarm system at the time nonfunctional. Although electricians were able to restore, the operability of the fire alarm, public address, and manual station systems within two weeks, the Port Authority questioned the WTC’s existing fire alarm system’s capability to provide reliable life safety

support functions. In particular, the existing system, which was developed and supplied exclusively for the WTC by the American Multiple System Company, was no longer manufactured, and the software was not supported. In addition, the 1993 bombing proved the system infrastructure to be vulnerable to a single point of failure. Based upon the inability to obtain spare parts and system support and the vulnerability of the system infrastructure, on March 17, 1993, the Port Authority signed a purchase order for \$1,930,000, authorizing the purchase of a new, state-of-the-art addressable fire alarm system for the WTC complex (including buildings 4 and 5, which were also protected by the fire alarm system protecting buildings 1 and 2) (PANYNJ 1993). New fire alarm drawings were developed for WTC 1, 2, 4, and 5 and were issued for bid on March 25, 1993. On April 5, 1993, the fire alarm installation project was awarded for construction. On March 26, 1997, PANYNJ issued another purchase order for \$3,500,000 to complete the fire alarm retrofit project.

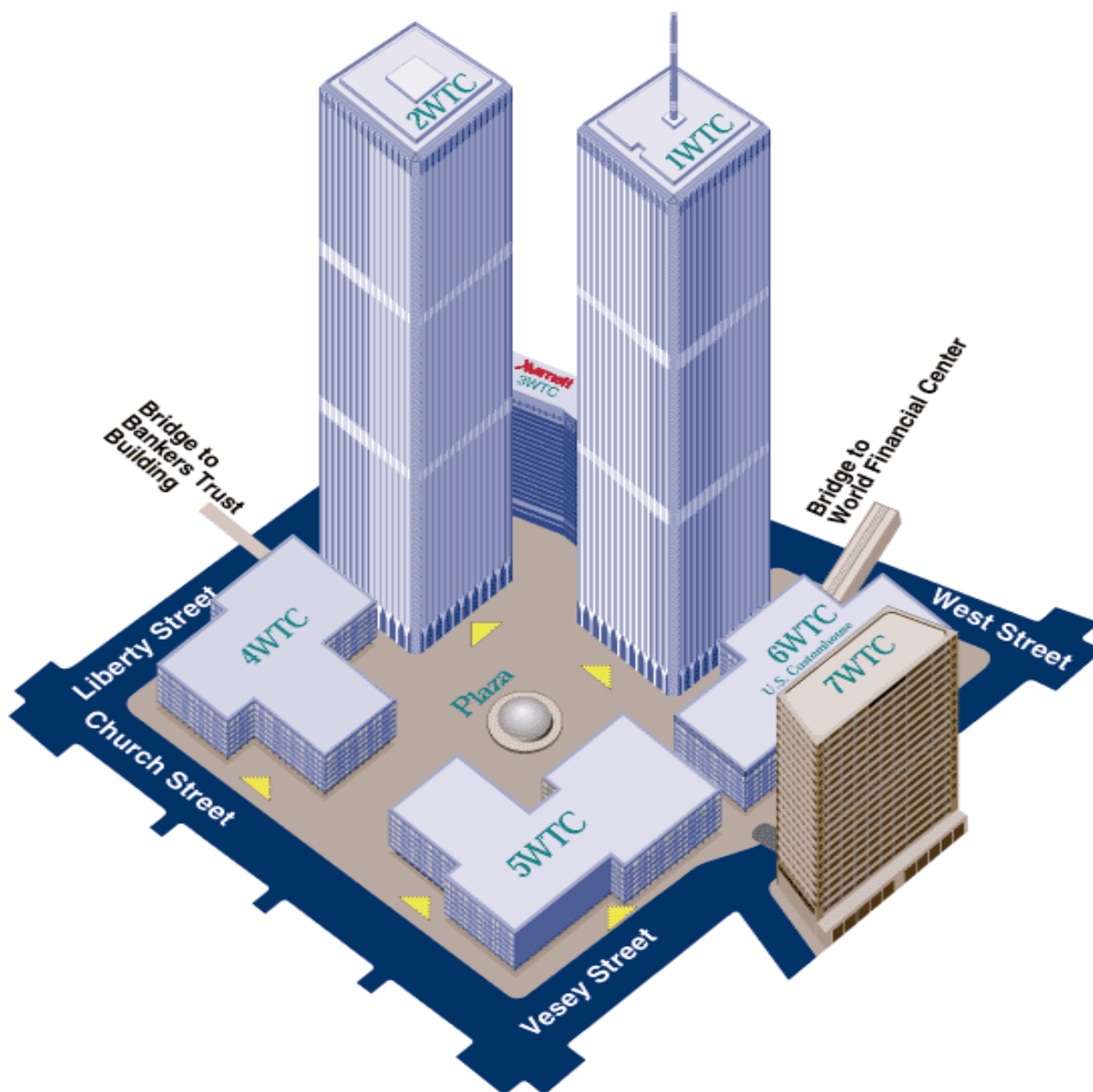

Source: Drucker 2001.

Figure 1-1. WTC complex.

The replacement fire alarm system was manufactured by Cerberus Pyrotronics Services, and was a MXL-V fire alarm system with emergency voice/alarm communication capabilities. The system supported a decentralized infrastructure that consisted of six independent fire alarm systems protecting WTC 1, WTC 2, WTC 4, WTC 5, Concourse Level, and the Sub-Grade Levels. The four buildings had a master monitoring and control Network Command Center (NCC) located at each building's Fire Command Station (FCS) which were located in the entrance lobby of each building. Building 4 was also provided with redundant remote NCC that monitored Building 5, and Building 5 was provide with a redundant remote that monitored Building 4. The Concourse and Sub-Grade master NCCs' were installed in the WTC 2 FCS, and remote NCCs' for the Concourse and Sub-Grade were installed in the WTC 1 FCS along with a remote NCC for WTC 2. Furthermore, a redundant remote NCC for monitoring and control of all six systems was installed in the OCC located on the B1 Level below WTC 2 (Drucker 2004).

Due to the scope of the fire alarm project, and since the bombing required the Sub-Grade Levels to undergo a major restoration, the fire alarm system design for the WTC site was separated into four sub-projects:

1. WTC 1 and WTC 2
2. WTC 4 and WTC 5
3. Concourse Level
4. Sub-Grade Level

The installation of the WTC 1 and WTC 2 fire detection and alarm systems was further separated into three phases to address the constructability of the new systems, while enhancing fire protection capabilities in the quickest manner possible and to ensure fire protection continuity during the switchover to the new fire alarm system. The phases were planned as follows:

Phase 1 – The scope of this phase required the installation of the backbone for the systems (see Fig. 1–2). The backbone consisted of the building's master fire alarm panel (MXL-V), remote transponder panels (MXL-VR), and amplifier cabinets. Terminal Strip Cabinets (TSC) were installed on each floor to provide cable termination for existing or new fire alarm devices that were wired back to the transponder panels during Phase III. Interface Cabinets (IC) were installed, which contained interface modules to provide monitoring and control functions between the existing systems (CR-7) and new system (MXL-V) during the transition. Older documentation (Marchese 1993) indicates the phase was originally scheduled to be completed in September 1993, while the Buchsbaum/Mizrahi 1994 article indicates both Phase I and II were to be completed by the beginning of 1995. In 1997, a memo was issued to the WTC 2 tenants indicating that Phase I was completed (Sileo 1997).

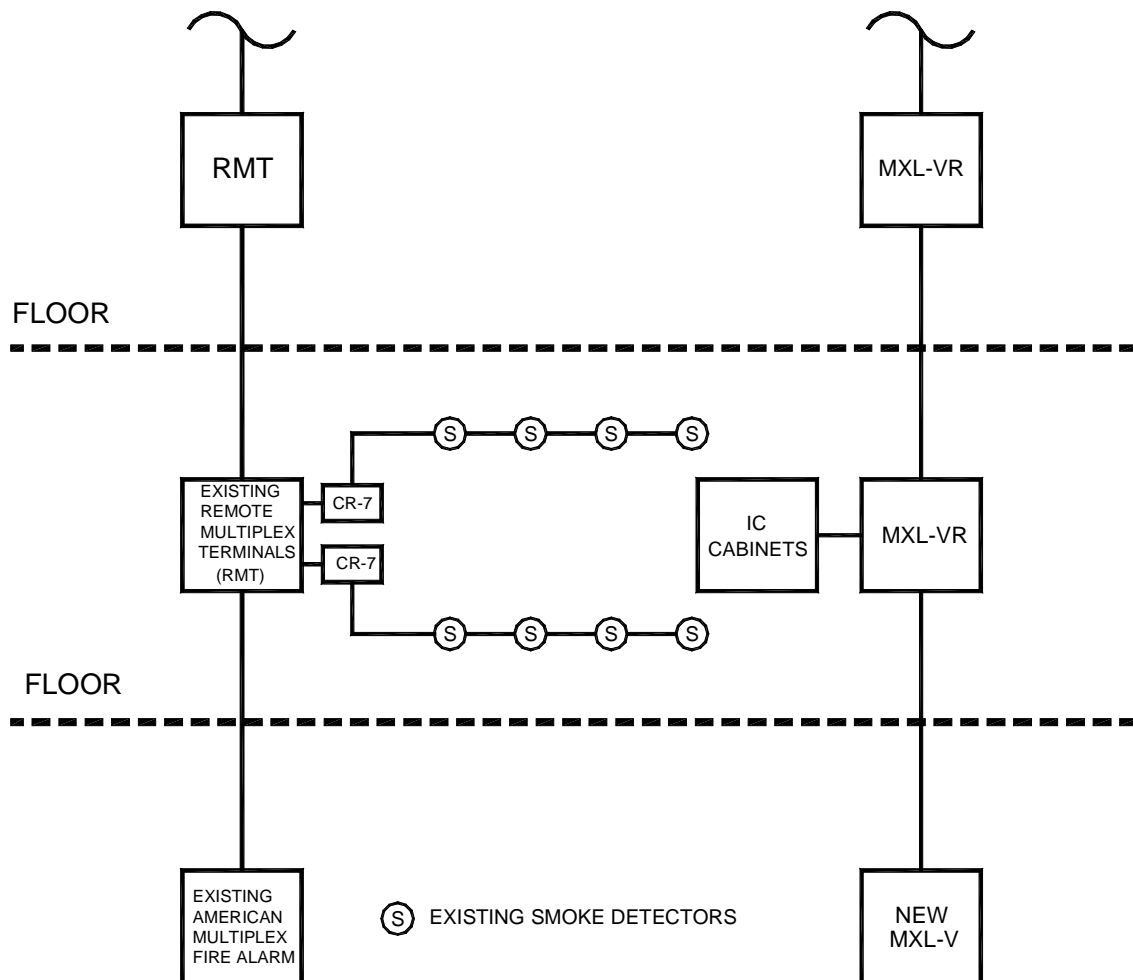

Figure 1–2. Phase I backbone.

Phase II – Transition of the monitoring and control of existing fire alarm devices to the new system was accomplished as Phase II (see Fig. 1–3). During this phase both the existing American Multiplex system and the MXL-V system were operating concurrently. Also, the new core area speakers, warden phones, and pull stations were connected to the new fire alarm system. Older documentation (Marchese 1993) indicates the phase was originally scheduled to be completed in October 1993, while the Buchbaum 1994 article indicates both Phase I and II were to be completed by the beginning of 1995. In 1997, a memo was issued to the WTC 2 tenants indicating that Phase II was completed (Sileo 1997).

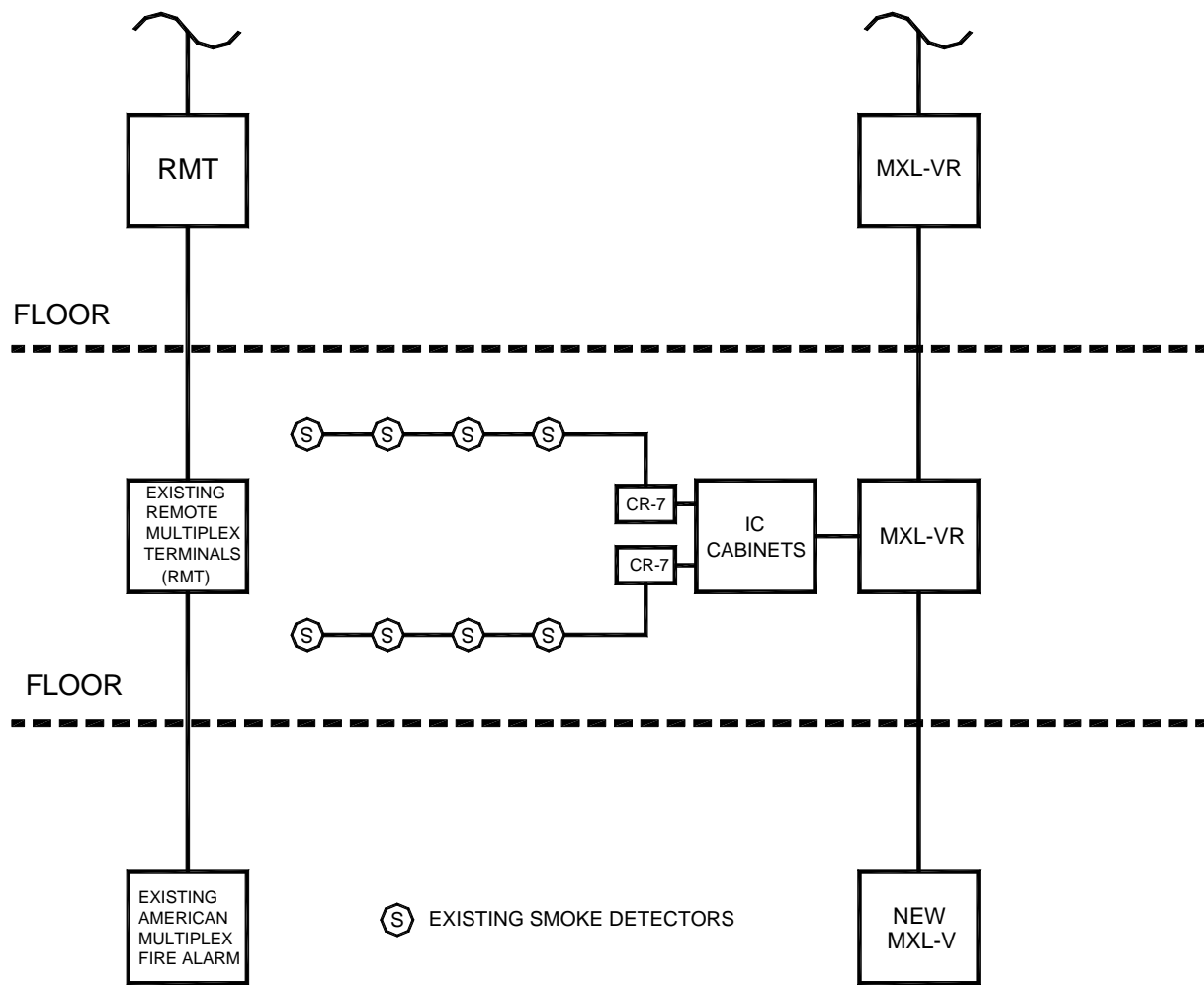

Figure 1-3. Phase II transition.

Phase III – This phase required replacing all existing fire detection devices, and expanding the new speaker and strobe capabilities into all tenant and mechanical spaces. All areas protected by the new fire alarm system were designed to be in compliance with the New York Building Code – Class “E” system requirements, and other applicable code criteria. The existing American Multiplex system was to be disconnected and removed. This had not occurred by September 11, 2001.

Although the original schedule for completion was not found, the Buchbaum 1994 article indicates this phase was planned to be completed by the end of 1996. In 1997, a memo was issued to the WTC 2 tenants indicating that the Phase III portion of the fire alarm system that included the installation of manual pull stations and warden telephones was completed (Sileo 1997). However, there are conflicting reports as to the actual status of the fire alarm project. The most recent report on the status of completion for the fire alarm retrofit indicated the following (PACO 2002):

1. WTC 1 – 85 percent complete.
2. WTC 2 – 80 percent complete.
3. WTC 4 and 5 – 60 percent complete.
4. Concourse Level – 100 percent.
5. Sub-Grade Levels – 0 percent complete.
6. Sub-Grade Levels Backbone Modification – 0 percent complete.
7. Convert existing fire alarm protection in Mechanical Rooms to new system – 40 percent complete.
8. Global Fiber Optic Loop interconnecting all six fire alarm systems – 0 percent complete.

It was estimated that 25 percent of the original American Multiplex system was still in use at the time of the attack (PACO 2002). Documentation was not found providing a description of the extent and what type (existing or new) of fire alarm protection was provided in each building on September 11, 2001.

This page intentionally left blank.

Chapter 2

NORMAL OPERATIONS AND FIRE EMERGENCY RESPONSE

The Port Authority of New York and New Jersey (PANYNJ or Port Authority) had a Fire Safety Plan for World Trade Center (WTC) 1, 2, and 7 that provided direction for fire emergency response and was organized around a hierarchy of staff associated with its implementation. At the top of this hierarchy was the WTC Fire Safety Director. The Fire Safety Director oversaw fire emergency response until the arrival of the Fire Department of the City of New York (FDNY or Fire Department), and was responsible for gathering all necessary information for the FDNY, which he/she relayed to the Chief upon his/her arrival. In WTC 1 and WTC 2, subordinate to the Fire Safety Director was the Assistant Fire Safety Coordinator, who was responsible for the availability and state of readiness of the Fire Brigade and the entire Emergency Response Team (members of the WTC Division of the Port Authority Police, who receive firefighting training and staff the WTC Fire Brigade). In WTC 7 the Fire Safety Director also performed the functions of the Assistant Fire Safety Coordinator as identified above. WTC 7 also had a Fire Brigade that the Fire Safety Director was responsible for organizing and training.

In addition to the WTC 1 and WTC 2 Assistant Fire Safety Coordinator, the towers had an Emergency Response Team consisting of Deputy Fire Safety Directors, Lobby Deputy Fire Safety Directors, Floor Wardens and Deputy Floor Wardens. Deputy Fire Safety Directors were responsible for performing the duties of the Assistant Fire Safety Coordinator in his/her absence and staffing the Fire Command Station (FCS) for the purpose of executing the fire safety plan. At the end of the hierarchical chain for WTC 1, 2, and 7 were Floor Wardens and Deputy Floor Wardens, who were responsible for assessing conditions and assisting in evacuation of floor occupants on their respective floors upon direction from the Fire Brigade and/or FCS. Floor Wardens, Deputy Floor Wardens, and their alternates were appointed tenants or employees of the WTC complex (SafirRosetti 2002; Kastner 1990; PANYNJ 2001; PANYNJ).

2.1 FIRE COMMAND STATION

WTC 1, 2, and 7 FCS were located in the lobbies of each building. WTC 1 and WTC 2 had redundant command centers. A back-up command center for WTC 1 was located at the Operations Control Center (OCC) on the B1 sub-grade level of WTC 2. The back up command center for WTC 2 was located in the WTC 1 FCS and the OCC. The FCSs facilitated two-way communication between mechanical rooms, elevator control rooms, and each floor through telephone, two-way fire alarm box, fire standpipe telephone, portable radios, public address systems, elevator intercom, and cellular telephones issued to Floor Wardens. Additional information and equipment valuable to the Emergency Response Team was also maintained at the FCSs. This information and equipment included copies of all appropriate building information, a minimum of one set of master keys for the buildings, a list of floor wardens and their contact information, and a list of mobility-restricted individuals and other tenants requiring special assistance in the event of evacuation (SafirRosetti 2002).

2.2 WTC 1 AND WTC 2 OPERATIONS COMMAND CENTER

The OCC for the WTC (located in level B-1 of WTC 2) was where WTC Operations and Management Staff evaluated the operation of the buildings' systems including elevators, intercoms, and communications systems. During a fire incident, Operations Management staff assisted with evacuation upon request. The staff of the mechanical section of Operations Management operated fire pumps and manually activated smoke control upon request. They also secured sprinkler water shutoff valves upon request of the Fire Safety Director or FDNY Chief Commanding Officer. The staff of the electrical section of Operations Management reset smoke detector or fire alarm panels upon the request of the Fire Safety Director or FDNY Chief Commanding Officer when the fire incident had been secured. The staff of the electrical section also responded to electrical incidents and remotely secured related equipment upon request.

The backup command center at the OCC provided redundancy to FDNY at any of the FCSs in WTC 1, 2, 4, and 5 to operate systems in any of the four buildings.

2.3 FIRE PREVENTION AND FIRE PREPAREDNESS PROCEDURES

2.3.1 Fire Drills

Fire drills were conducted at WTC 1, 2, and 7 every six months under the direction of the Floor Warden and Deputies of the Floor Warden. During the drills all employees, occupants, and visitors of the floor where the drill was conducted were physically required to leave their office areas and evacuate to a central hallway, near a stairwell. Building tenants and persons designated as Floor Wardens and Deputy Floor Wardens were informed of the location, date, and time of the fire drill. Floor Wardens and Deputy Floor Wardens were responsible for informing all employees on their floor of the date and time of the drill.

2.3.2 Training Exercises

In addition, regular training exercises were conducted by the Port Authority and the Fire Department (the designated lead authority responsible for command of fire incidents at the WTC complex). The exercises oriented new staff and served as a reminder to existing staff in the Port Authority and Fire Department with the building, its equipment, and the appropriate emergency response procedures. In 2001, twelve of these training exercises were conducted before September 11th. Although the incidents of September 11, 2001, were beyond the expected scope of emergency response personnel, the emergency response plan was implemented, and many of the emergency response staff involved possessed a high level of familiarity with the building and its associated emergency procedures.

2.3.3 Fire Prevention Inspections

Fire inspections were performed annually in each tenant space to limit the risk of life and property loss from fire. It was the intent that as a result of the inspections, the likelihood of a fire occurring was minimized, or that if a fire occurred, the spread of the fire and its duration would be limited. Tenants were advised to limit combustibles and avoid locating combustible materials in aisles, under desks, or

piled on top of office furniture. Smoking was not permitted in the buildings. Storage of materials was not permitted within 18 in. of the ceiling and sprinkler heads.

A written report was prepared for all fire inspections and was maintained by the Fire Safety Office. Any deficiencies or violations were noted in the report and forwarded to the appropriate person in the tenant space for correction.

In addition to annual tenant space inspections, WTC staff conducted daily operational inspections. The purpose of these inspections was to ensure that all necessary exits were maintained and available for egress, all exit hardware was functional, and there were no obstructions to means of egress within the WTC.

2.4 ALARM NOTIFICATION

Staff notification of a fire or smoke condition occurred when a smoke detector or sprinkler activation transmitted an alarm to the FCS in the affected building. Staff notification also occurred through activation of a manual pull station by a building occupant or a phone call reporting a fire or smoke condition to the WTC Police Desk and/or FCS.

Occupant notification in WTC 1 and WTC 2 was initiated manually from the FCS by the Fire Safety Director or his designees.

Occupant notification in WTC 7 was automatically provided in the event of fire alarm system activation.

2.5 FIRE SAFETY PLAN

Upon discovery of fire or smoke, the Fire Safety Plan called for occupants to activate the nearest building manual fire alarm station, typically at the intersecting corridor, and to notify the WTC police via telephone. The Police Desk would dispatch the Fire Brigade and transmit the alarm to the Fire Department. The WTC Fire Safety Director was responsible for transmission of the fire alarm and notification of the Fire Brigade, Floor Warden(s), and building occupants. If necessary, the Fire Safety Director utilized the Security Staff to restrict building occupant access to the area(s) affected by the incident. Staff at the Visitors' Desks were also notified to stop issuing visitors' passes to the area(s). The managers of the Windows on the World restaurant and Top of the World Observation Deck were notified of any facility emergency by the OCC Supervisor. The purpose of this notification was to reduce any panic or anxiety that may be experienced by tenants, visitors, and other guests upon observing the response of emergency personnel to the building/complex. Notification of an incident to building occupants was performed through the Property Management staff, which coordinated with the Fire Safety Director on issues directly affecting building tenants. During the emergency incident it was the responsibility of the Property Management Staff to supply information to the building tenants as appropriate.

The Fire Safety Director could also initiate evacuation from the area or the entire building. In this situation, the fire alarm emergency voice communication system was activated on the floors to be evacuated. Per Tenant Fire Safety Procedures exercised during regular fire drills, building occupants proceed to the corridor areas to wait for verbal instructions provided over the fire alarm emergency voice

communication speakers. Occupants were instructed to evacuate the floor(s) using stairways to the designated “safe” area, which was at least three levels below the fire floor. Occupants were not to use the elevators. Occupants with special needs, requiring assistance in evacuating, were to be aided by the Floor Warden(s).

The WTC Fire Brigade members would respond to the floor directly below the fire floor and proceed to the fire floor utilizing stairways. Upon the initiation of evacuation procedures, Fire Brigade members conducted searches of the floor and utilized firefighting appliances as necessary to control the fire as much as possible until the arrival of the Fire Department, whereupon the Fire Brigade would transfer firefighting operations to the Fire Department. While in control of firefighting operations, however, the Fire Brigade was responsible for keeping the FCS and WTC Police Desk informed of all operational details.

Floor Wardens were to notify the FCS of any non-ambulatory or mobility restricted individuals requiring special assistance during evacuation, utilizing the fire alarm Floor Warden Phone system. Tenants requiring special assistance in evacuating the WTC would be assisted by members of the Fire Brigade upon notification of fire or smoke in the buildings. Fire Brigade members were dispatched via staffed freight elevators to the floor directly below the affected floor. Based on available information, the Fire Brigade would take the freight elevator to the fire floor, or if conditions were severe and the use of the freight elevators would expose these tenants to danger, tenants requiring special assistance were hand carried down the stairwells by members of the Fire Brigade to areas of refuge.

Occupants of the building located on the floor of fire incidence and above were evacuated to locations at least three or more floors below the fire floor. It was the responsibility of Floor Wardens via the fire alarm Floor Warden Phone system to inform the FCS (staffed by Deputy Fire Safety Directors) of the evacuation actions taken and location of evacuees.

If stairways serving the fire floor or floors above the fire floor were not usable due to fire, smoke, or overcrowding situations, the use of elevators could be considered for evacuation as long as the elevators used did not serve the fire floor, and the elevators did not connect to other shafts opening onto the fire floor. Only elevators staffed by fire fighters or other trained building personnel could be utilized for evacuation.

2.6 FIRE DEPARTMENT RESPONSE

The primary objective of the Fire Department was to perform rescue operations of persons in the building. This was achieved through ventilation of the building, entry into the building, and searches for persons trapped in the building. Another important objective of the Fire Department was to control and extinguish the fire. The Chief of the Fire Department was the highest-ranking uniformed firefighter and was responsible for all operations when on the scene.

2.6.1 Alarms

Alarms were received by FDNY by several means. “Nine-one-one” telephone calls were made to report fire. Activation of the fire alarm system within the buildings transmitted an alarm to the Fire Department. Fire alarms were also received from street pull boxes.

Upon alarm notification, Fire Department units were immediately dispatched to the scene. The average response time of the Fire Department in 2001 was less than 5 min.

2.6.2 Communication

Fire Department communications were achieved through VHF radios and hand-held radios. The VHF radios were used for dispatching units as well as communicating between apparatus (trucks, engines, etc.). Hand held radios were used on site during tactical operations. Repeaters were installed in the WTC complex after the 1993 bombing to amplify radio signals and help alleviate these difficulties.

Communications between the Lobby Command Post and Fire Department units operating on upper floors were achieved through the fire alarm's Standpipe Telephone System hard wire phones as well as hand held radios. The fire alarm hard wire phones consisted of Floor Warden phones, which were in-house fire alarm phones that connected the FCS in the lobby to each floor, and Standpipe Telephone phones, which connected the FCS to the fire pump room and each Standpipe Phone outlet.

FDNY has established firefighting procedures for high-rise office buildings. The main objectives are to locate, control, and extinguish the fire. The strategy in achieving these objectives includes determining the specific fire floor, search of the fire floor and the floor directly above, and evacuation of any persons found during the search. The building's elevators, ventilation system, communications systems, and fire pumps are controlled and utilized. The ultimate goal is to control and extinguish the fire.

2.6.3 Support from Neighboring Fire Departments

FDNY maintained mutual agreements for two-way support with fire departments of neighboring jurisdictions, including Nassau and Westchester Counties, Jersey City, and the cities of Mt. Vernon and Yonkers. Historically, members of FDNY have responded to alarms in other municipalities and vice versa.

This page intentionally left blank.

Chapter 3

ORIGINAL FIRE ALARM SYSTEM PRIOR TO THE 1993 BOMBING AND MODIFICATIONS SUBSEQUENT TO 1993

The pre-1993 system outlined for the World Trade Center (WTC) encompassed the following facilities:

- WTC 1
- WTC 2
- WTC 4
- WTC 5
- Concourse Level
- Sub-Grade Level

The system integrated detectors and alarm devices from the various buildings, to be tied into a control panel for that building or level. All control panels simultaneously annunciated alarms and troubles at the Operations Control Center (OCC).

The system consisted of American Multiplex Remote Monitoring Transponders (RMT), on every third floor, connected to the Digital Computer and Console in the OCC on the B-1 Sub-Grade Level. The Transponder monitored Pyrotronics CR-7 Equipment connected to type DI-2, DI-3, DI-4A, and DI-6 smoke detectors (non-addressable type), Pyrotronics System 3 panels, tenant proprietary systems, waterflow switches, tamper switches, and control contacts (PANYNJ 1986).

Pyrotronics XL3 smoke detector systems, with addressable type detectors, were installed in the mechanical equipment rooms of both WTC 1 and WTC 2, and connected via a CXL Communication Device to a console in the OCC.

Manual Pull Stations were wired to an existing Executone system which alarmed directly to the Fire Department.

The Public Address Communication System with manually activated selection of floor was also located at the OCC. Alarms from these systems were called in to the Fire Department, manually, by the Port Authority Police on duty 24 h a day at the Police Desk.

3.1 FIRE ALARM SYSTEM

The Fire Alarm System in the WTC combined fire alarm signaling with an intercom, enabling fire safety personnel to speak to the person turning in the alarm. Alarms could be initiated at break glass stations in

public and common areas throughout the WTC. Control and intercom equipment for the system were located in the Police Security Room, on Level B1.

3.1.1 Description

Figures 3-1, 3-2, and 3-3 illustrate the break glass stations used in the pre-1993 fire alarm system. The break glass stations combined a break glass alarm station and a two-way intercom in one unit. The alarm-setting mechanism was exposed by opening the spring-loaded door catch (see Figs. 3-1 and 3-2).

The glass rod was broken by pushing the spring-loaded pushbutton. A protective shield helped to stop flying glass (see Figs. 3-2 and 3-3). The switch actuating plunger activate the alarm. The mechanical relationship between the glass rod and the pushbutton is shown in Section B-B of Fig. 3-3.

The speaker/microphone, behind the grille, permitted conversation over the fire intercom system to the Police Security Room on Level B1. The break glass stations were model C3002, manufactured by Executone, Inc., Long Island City, New York 11101.

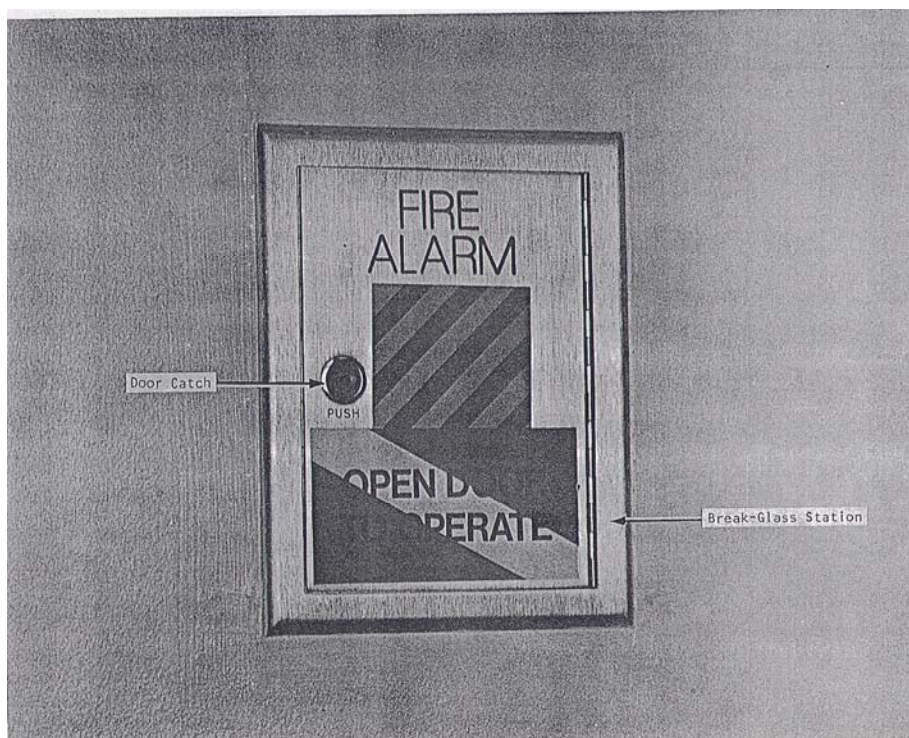

Source: PANYNJ 1986. Reproduced with permission of The Port Authority of New York and New Jersey.

Figure 3-1. Typical break-glass station.

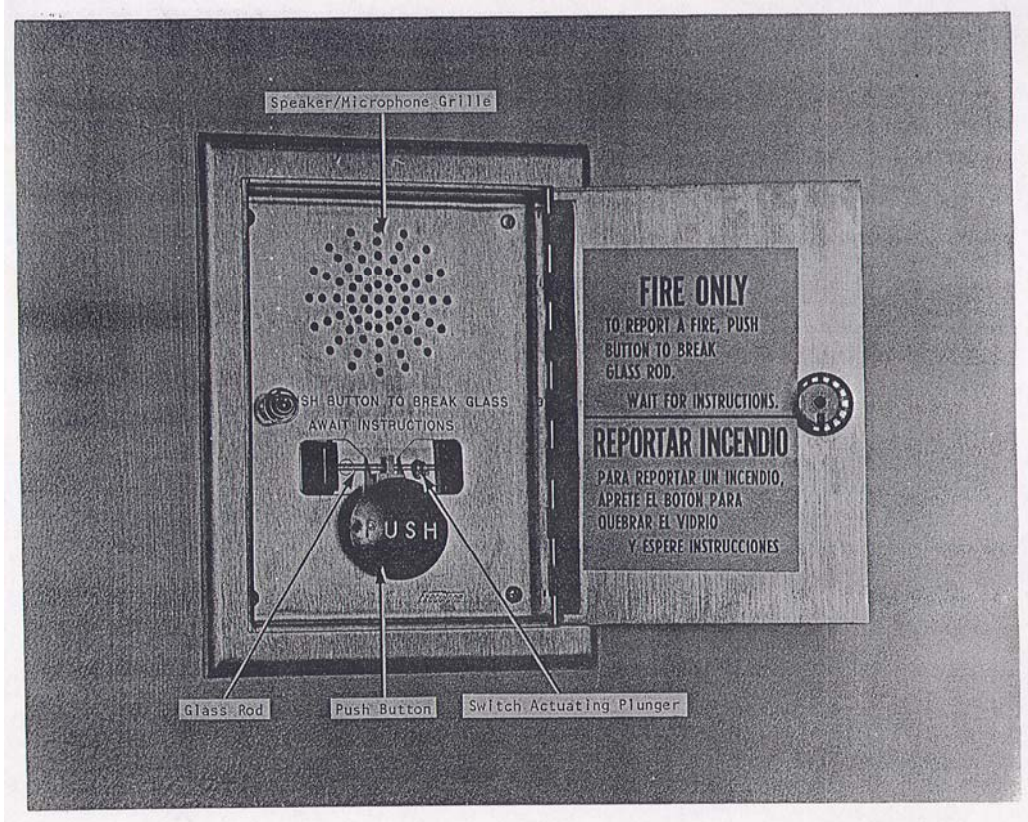

Source: PANYNJ 1986. Reproduced with permission of The Port Authority of New York and New Jersey.

Figure 3–2. Interior of break-glass station.

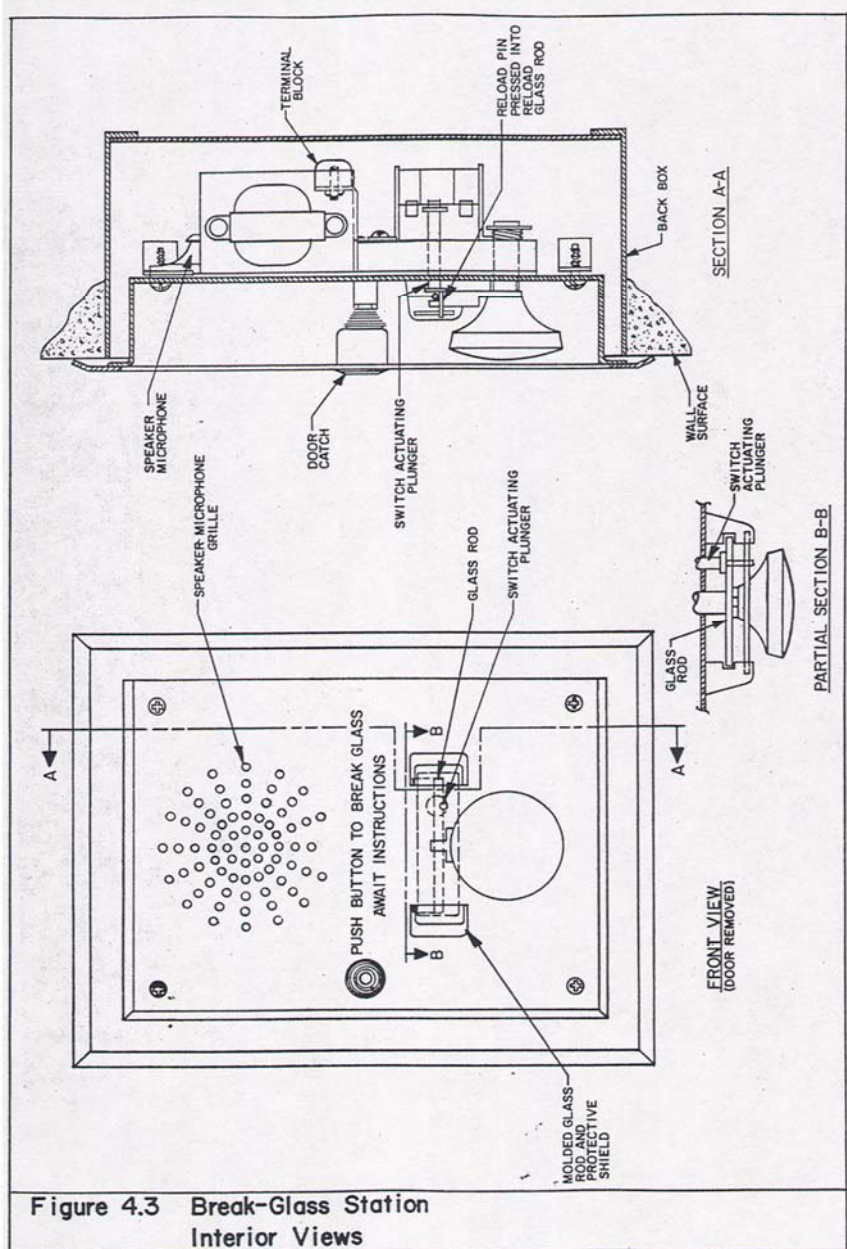
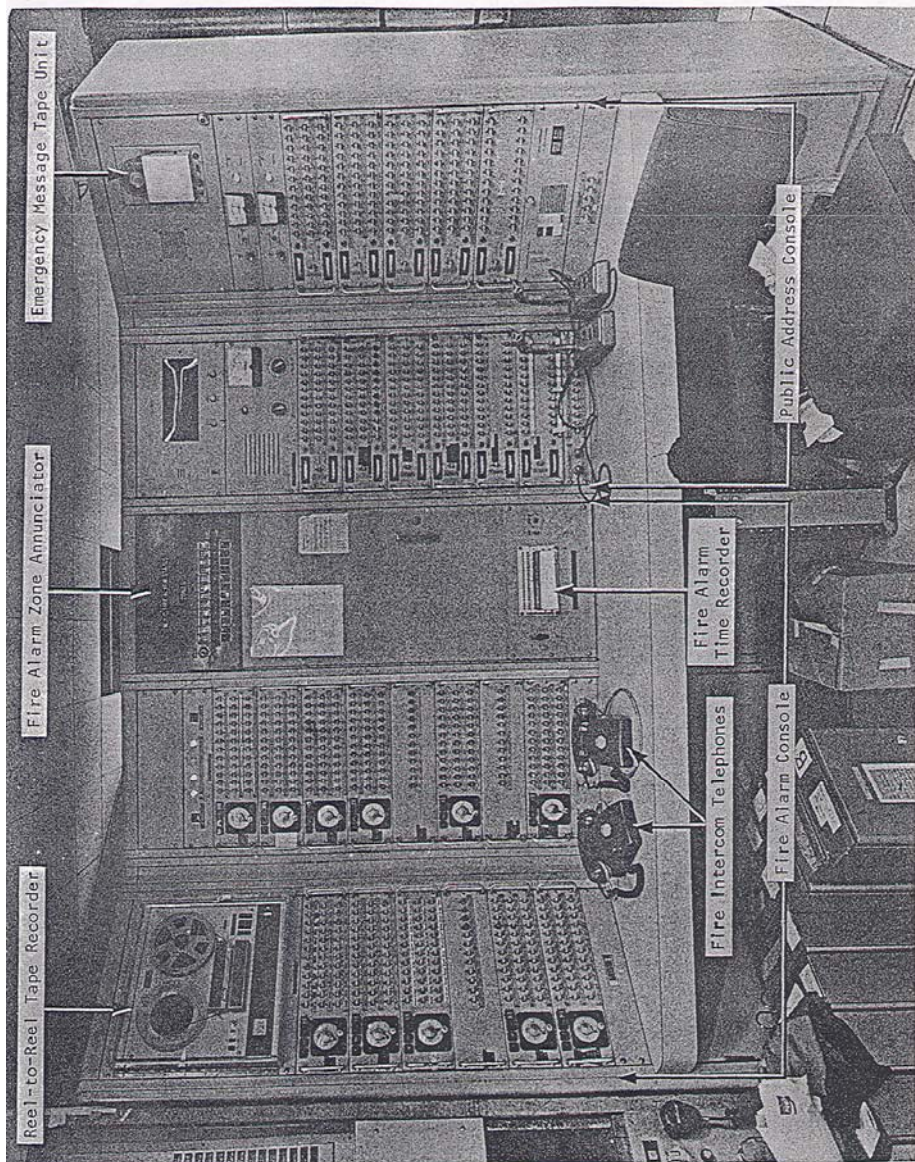

Figure 4.3 Break-Glass Station Interior Views

Source: PANYNJ 1986. Reproduced with permission of The Port Authority of New York and New Jersey.

Figure 3–3. Break-glass station.

The Fire Alarm Console (see Fig. 3–4) contained the equipment that processed fire alarms called in from break glass stations, retransmitted alarms to the City Fire Alarm Signal Boxes, and controlled the intercom for each break glass station (PANYNJ 1986).



Source: PANYNJ 1986. Reproduced with permission of The Port Authority of New York and New Jersey.

Figure 3–4. Fire alarm console.

Each section of the Fire Alarm Console contained many Fire Alarm and Intercom Panels (see Figs. 3–4 and 3–5). Each fire alarm and intercom panel contained: illuminated intercom channel selector switches, a fire call button, a city fire alarm cancel button, a station reset button, a zone test button, an adjustable city alarm delay timer for calling in city fire alarms, a fixed timer designed to delay broadcast of an alerting signal to the fire zone until the console operator had 20 s to answer the call, and a buzzer indicating that someone activated a break glass station.

Each panel represented a separate fire zone and actuated a separate New York City Fire Alarm Signal Box by means of a remote electrical trip. Each intercom channel selector switch served an individual break glass station and illuminated when that station initiated a fire alarm. The switch position corresponded to the intercom channel (A or B) to be used.

The buzzer sounded when an alarm was called in from a break glass station or an intercom channel selector switch was actuated. The Fire Call button actuated the City Fire Alarm Signal Box for that zone independent of calls from break glass stations. The City Fire Alarm Cancel button defeated the initiation of a City fire alarm from a break glass station, provided that the adjustable City alarm delay timer had not run out.

The Station Reset button stopped the internal 20-s timer from actuating an alerting signal directed to the fire zone; no alerting signal was connected to that timer. The appropriate intercom channel selector switch also had to be activated. The Zone Test button tested the supervisory circuits of the panel. The Fire Alarm and Intercom Panels, model M423-36, were manufactured by Executone, Inc.

The Reel-to-Reel Tape Recorder (see Fig. 3–5) transcribed conversations made over the fire intercom system. It was capable of recording, at 3 ¾ in./s or 7 ½ in./s, intercom channels A and B simultaneously. The recorder was manufactured by Sony for Executone and was Sony Model 666-D, Executone Model M432.

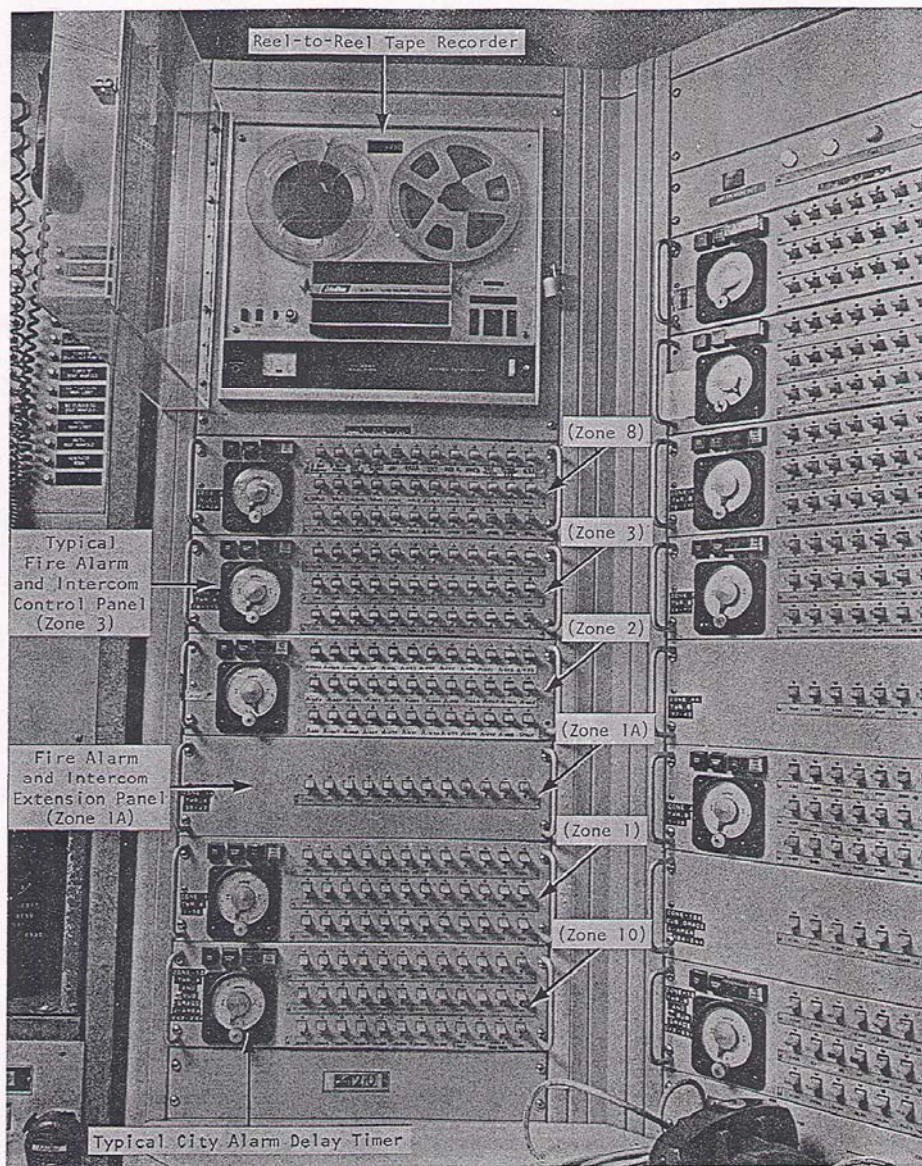

Source: PANYNJ 1986. Reproduced with permission of The Port Authority of New York and New Jersey.

Figure 3-5. Fire alarm console (Zones 1, 2, 3, 8, 10).

3.2 SMOKE DETECTION AND ALARM SYSTEMS

The pre-1993 Smoke Detection and Alarm Systems in the WTC are dealt with in this section (PANYNJ 1986). Three types of systems are described; Interior Return Air, Elevator Lobby, and the ventilation ducts in the Mechanical Equipment Rooms.

3.2.1 Interior Return Air Smoke Alarm System

The function of the Interior Return Air Smoke Alarm System was to alert Police Security Room personnel to the presence of smoke or other combustion products in the return air ducts of individual floors. The ionizations type detectors were in the hung ceiling of each tenanted floor, close to the intake of the return air ducts. A typical installation is shown in Fig. 3-6.

The detectors were connected to a computer-multiplex system which scans each smoke detector and reports alarm conditions to the Police Security Room on Level B1. The automatic computer and the vertical panel computer performed separate alarm functions. The automatic computer operated the alarm printout teletype, and the vertical panel computer operated the “horn.”

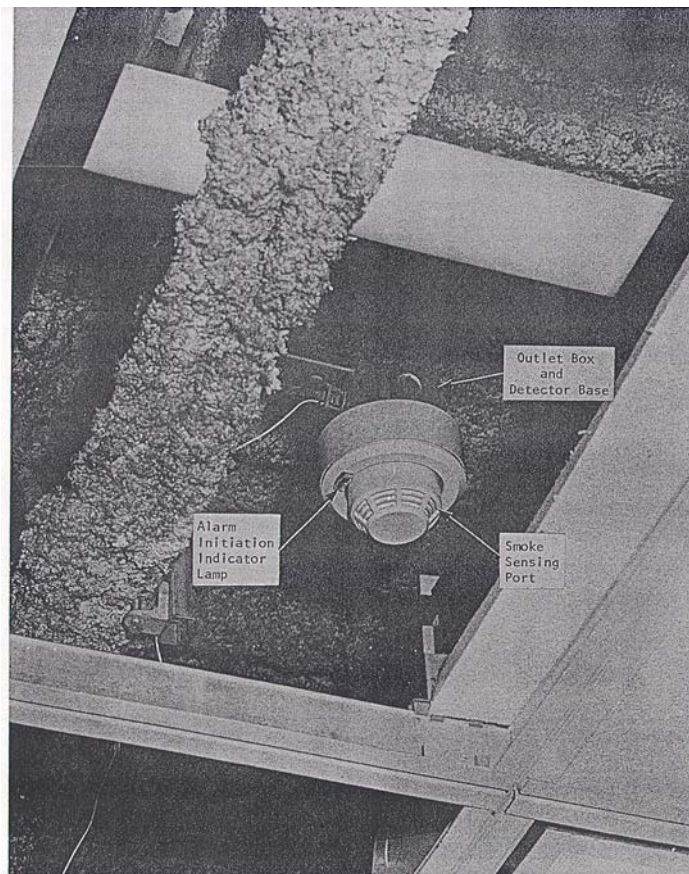

Source: PANYNJ 1986. Reproduced with permission of The Port Authority of New York and New Jersey.

Figure 3-6. Typical interior return air smoke detector (ceiling tile removed).

3.2.2 Elevator Lobby Smoke Alarm System

There was at least one smoke detector at the ceiling of each elevator lobby, directly above the elevator call button (see Fig. 3–7). These detectors had two functions: (1) like the interior return air smoke detectors, they transmitted a smoke detection signal to the Police Security Room; and (2) they caused the elevators to return to their main lobby or to an upper floor.

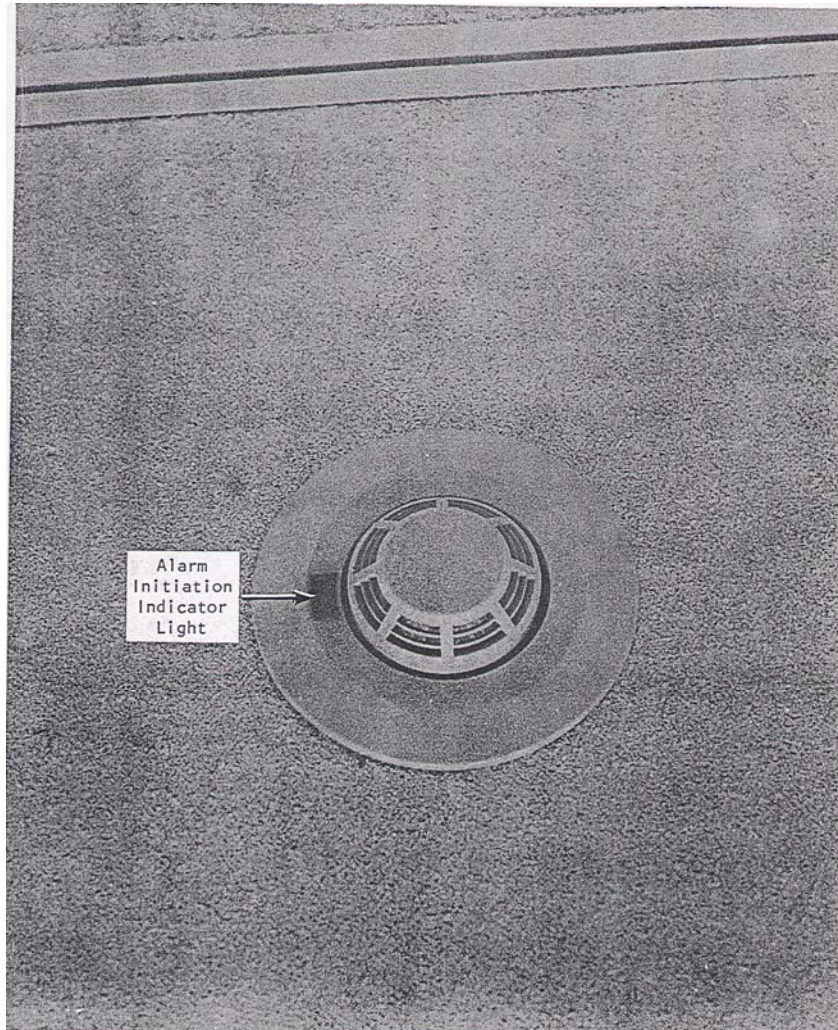

Source: PANYNJ 1986. Reproduced with permission of The Port Authority of New York and New Jersey.

Figure 3–7. Elevator lobby smoke detector.

3.2.3 Ventilation Smoke Alarm System

The Ventilation Smoke Alarm System monitored the supply and return air ducts in the Mechanical Equipment Rooms (MERs) in the WTC. The function of the system was to shut down the affected ventilation fans and alert appropriate personnel when smoke or other combustion products were detected in the supply or return air ducts. The MER exhaust ducts were monitored and controlled in a similar manner.

The ventilation smoke alarm system was comprised of air duct detectors, pendant-mounted detectors, control panels, and bells. The air duct detectors were mounted on the supply and return air ducts of the heating, ventilating, and cooling (HVAC) units in the MERs (see Figs. 3–8 and 3–9). The pendant-mounted smoke detectors monitored the air entering the MER exhaust fan inlets. Figure 3–10 shows a typical installation of one of these detectors.

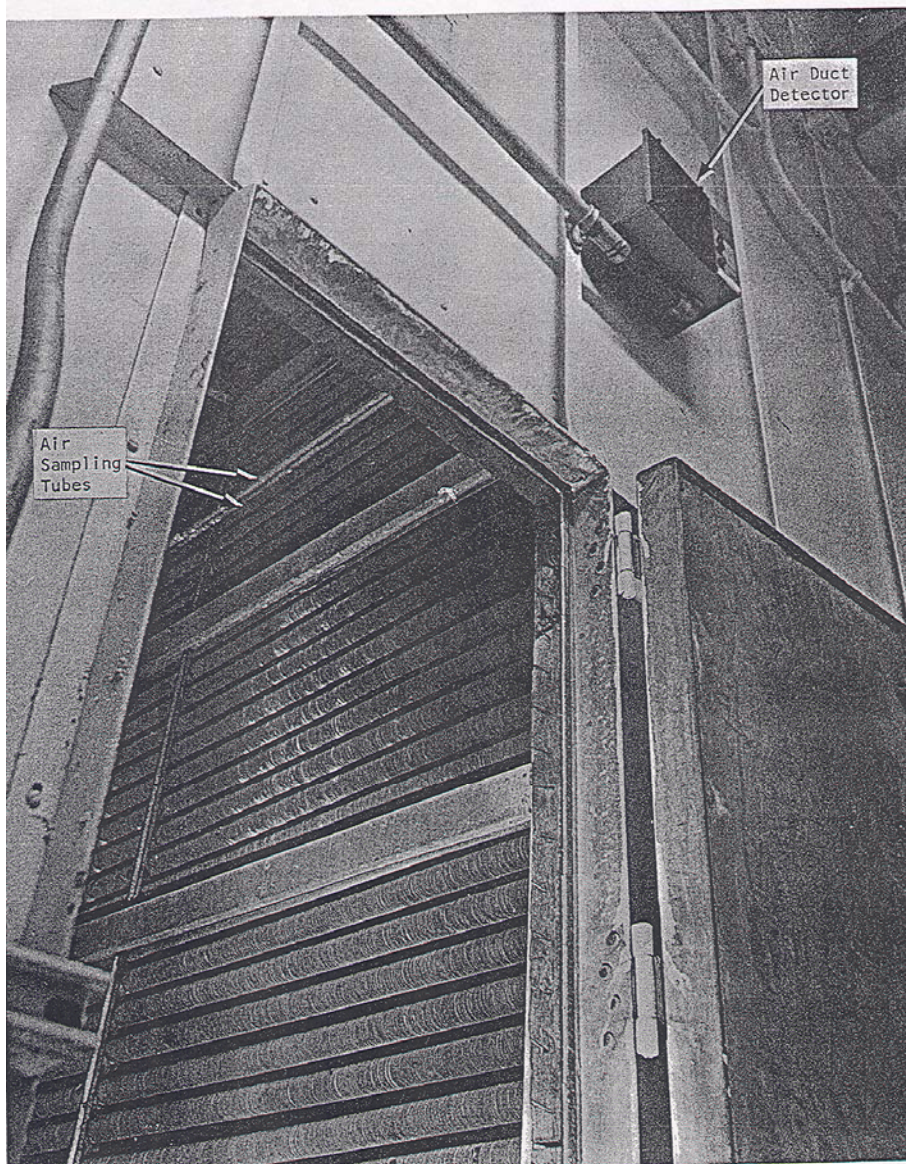

Source: PANYNJ 1986. Reproduced with permission of The Port Authority of New York and New Jersey.

Figure 3–8. Typical supply air duct detector installation.

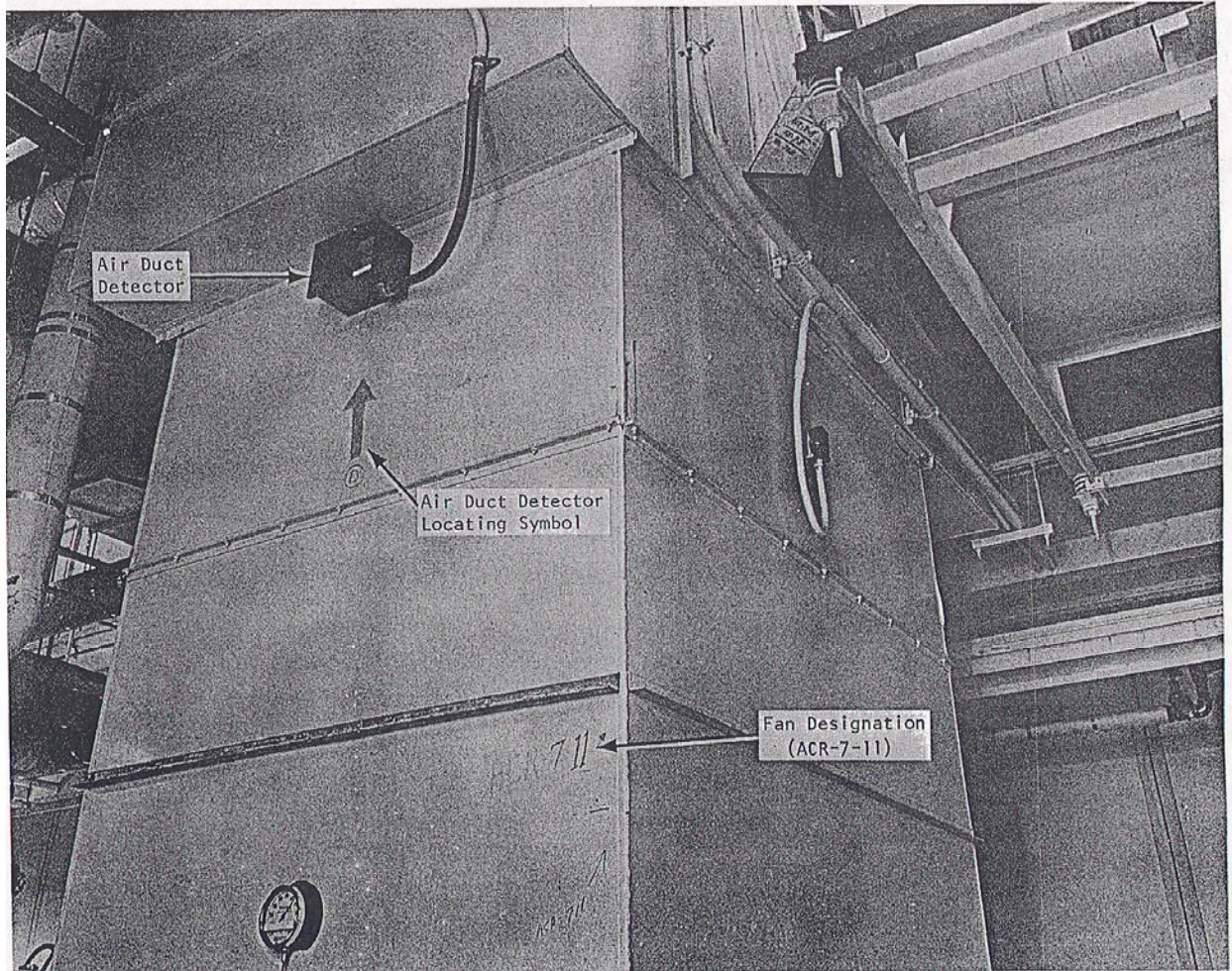

Source: PANYNJ 1986. Reproduced with permission of The Port Authority of New York and New Jersey.

Figure 3-9. Typical return air duct and duct detector.

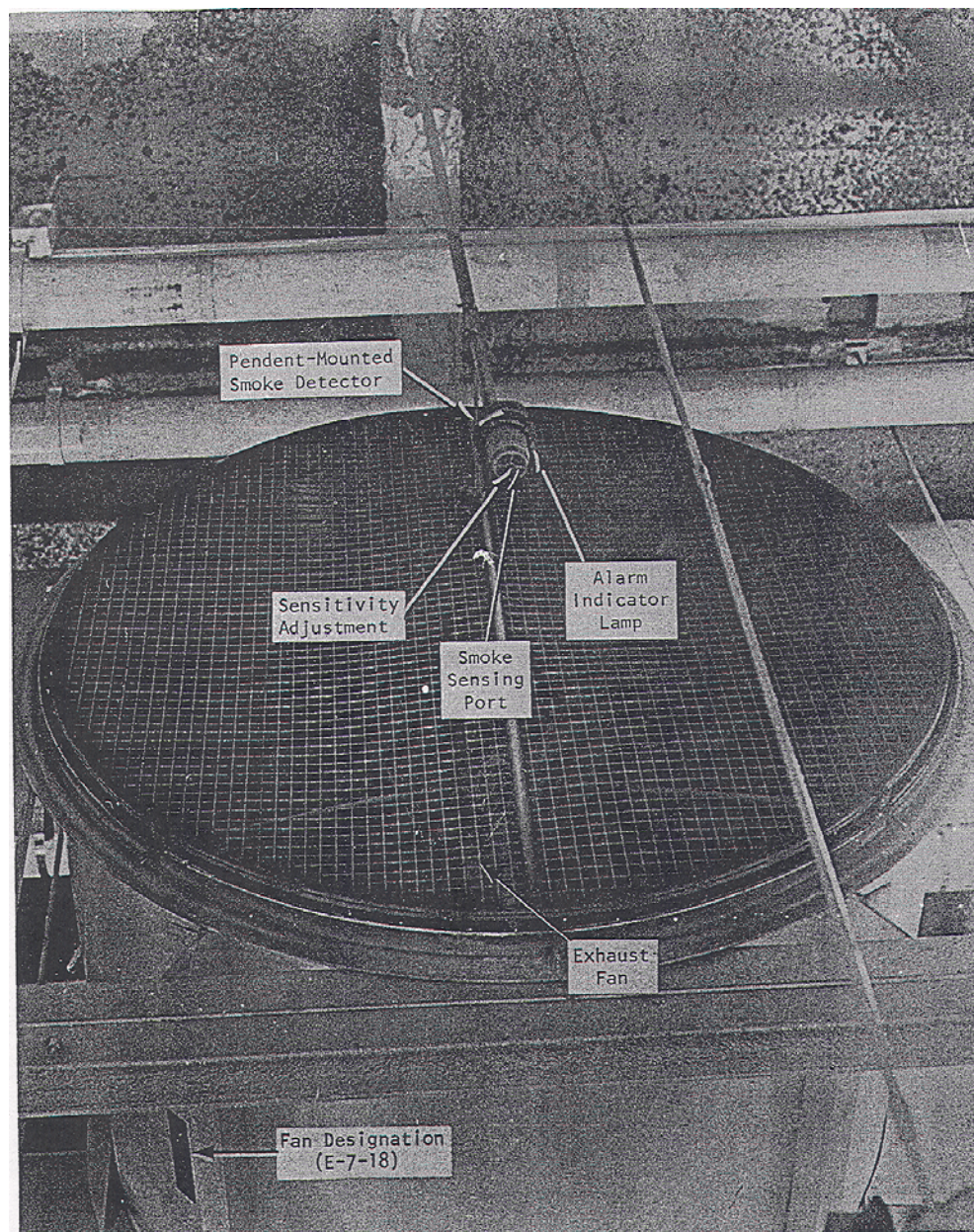

Source: PANYNJ 1986. Reproduced with permission of The Port Authority of New York and New Jersey.

Figure 3–10. Typical pendant mounted smoke detector.

The air duct smoke detectors were ionization-type devices that sensed products of combustion that may have been circulating in the air ducts. When such gases or smoke were detected, ventilation fans were automatically shut down to prevent recirculation of the smoke and/or gases. In addition, an alarm bells rang in the affected MER, and an alarm message was printed on the printer in the Police Security Room. A maintenance electrician and mechanic were then dispatched to the affected MER to investigate the cause of the alarm and take the necessary corrective action.

3.2.4 Tenant Smoke Alarm Systems

Many tenants had their own Smoke Alarm Systems. The designs of these systems were varied, and their descriptions are beyond the scope of available documentation.

3.3 PUBLIC ADDRESS SYSTEM

The All-Purpose Public Address System (PA) (PANYNJ 1986) was provided with two channels of sound transmission: Channel “A” and Channel “B.” For voice paging between zones both channels were available. Communications from the skylobbies could be executed only through Channel “A.” The circuitry of the PA system allowed for both simultaneous and independent announcements to selected speaker zones or areas.

Voice announcements were made via the microphones either at the Control Center Console at the Police Desk on Level B1 (Elevation 294 ft) or at the Elevator Starter Panels (ESPs) in the Main Lobbies or Skylobbies. There was one ESP in the Main Lobby of each tower and one ESP on the 44th and 78th floor skylobby of each tower. From these locations announcements could be made to any zone or area of the WTC during an emergency, including a fire situation.

3.3.1 Speaker System

Speakers used in this system were positioned so that all areas of the WTC complex received voice transmissions from the various microphone locations. The speakers were in stairways, corridors, and ventilation ducts of the core area of the WTC. Speakers in the corridors, stairways, and ducts were positioned so that voice transmissions could be adequately relayed to all occupants in that particular floor or stairway area.

There were basically two types of speakers in the WTC: the horn loudspeaker (see Fig. 3–11) and the recessed ceiling speaker (see Fig. 3–12) (PANYNJ 1986).

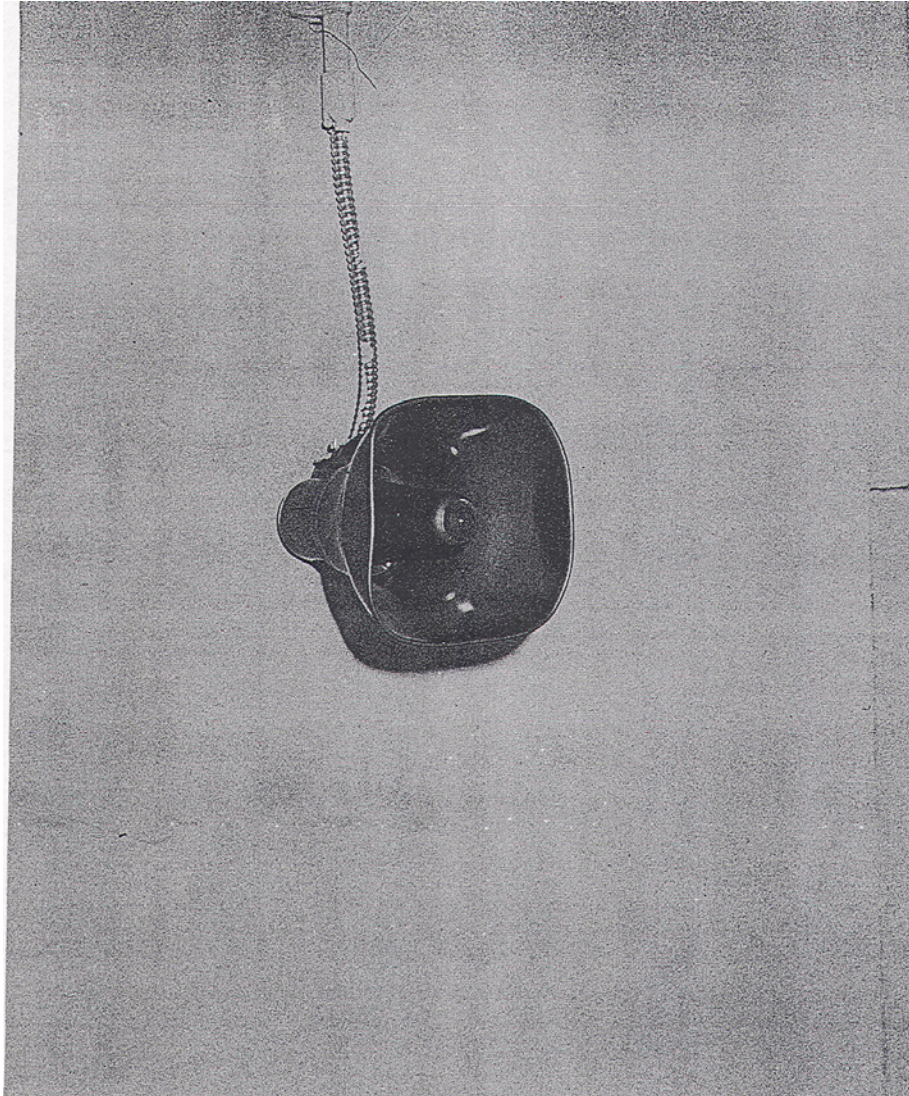

Source: PANYNJ 1986. Reproduced with permission of The Port Authority of New York and New Jersey.

Figure 3–11. Horn type speaker in a stairway enclosure.

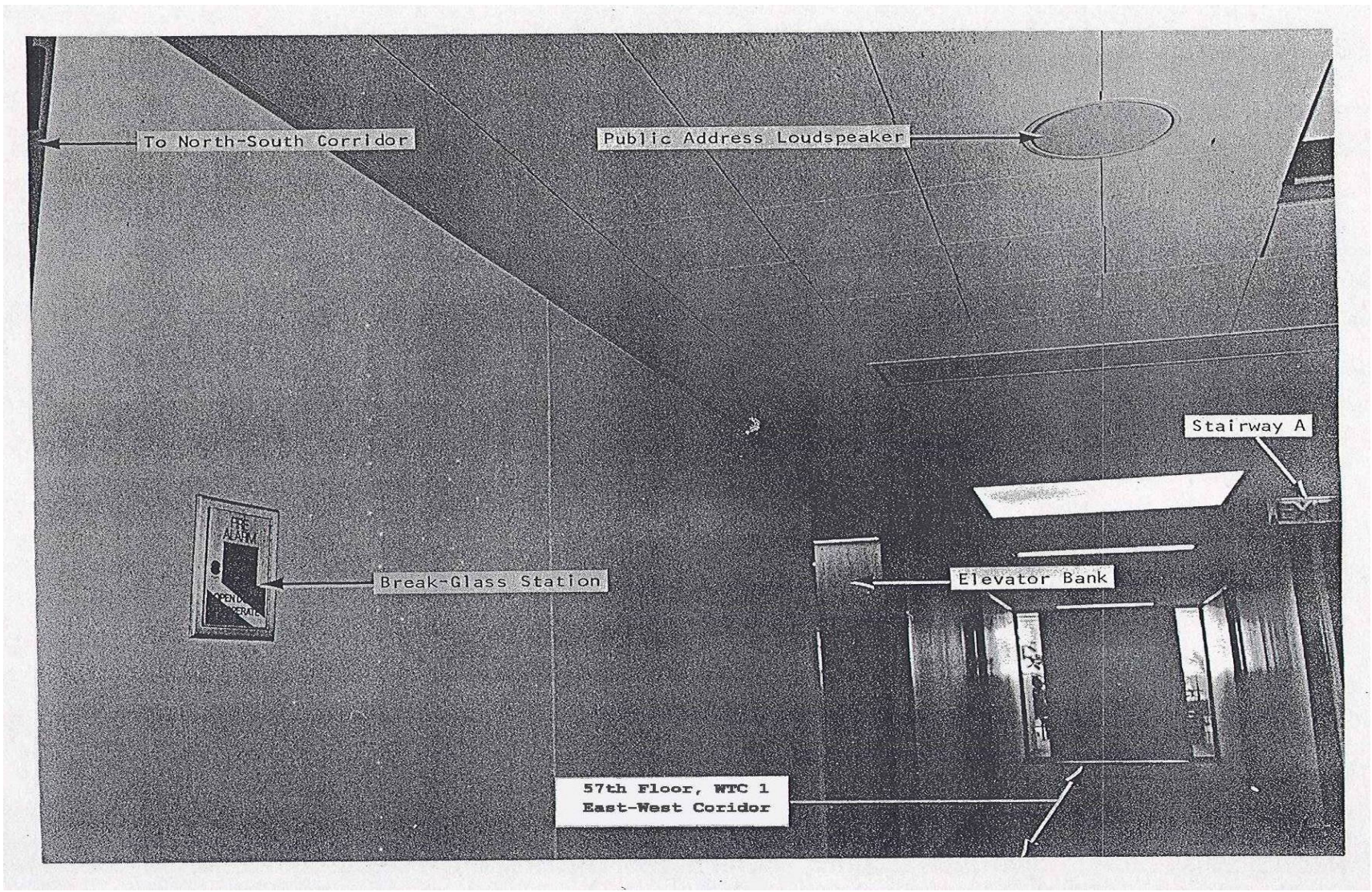

Source: PANYNJ 1986. Reproduced with permission of The Port Authority of New York and New Jersey.

Figure 3-12. Recessed speaker in corridor.

3.4 PUBLIC ADDRESS CONSOLE

The Public Address Console was the right-hand portion of the Control Center Console that included the Fire Alarm Console (see Fig. 3-13) (PANYNJ 1986). The Control Center Console was in the Police Security Room on Level B1. The Public Address Console was the heart of the All-Purpose PA System and contained most of its controls and monitors (see Fig. 3-14).

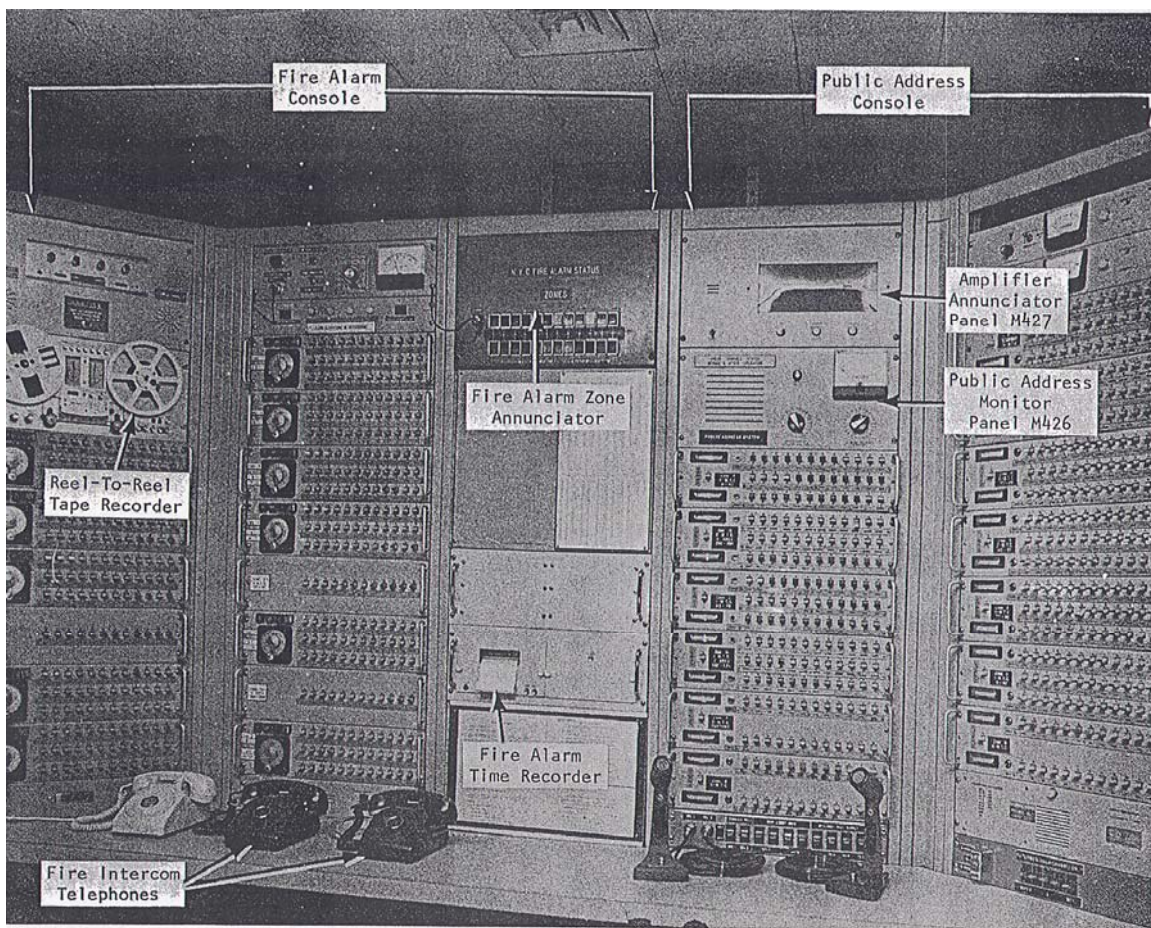

Source: PANYNJ 1986. Reproduced with permission of The Port Authority of New York and New Jersey.

Figure 3-13. Control center console police desk Level B1.

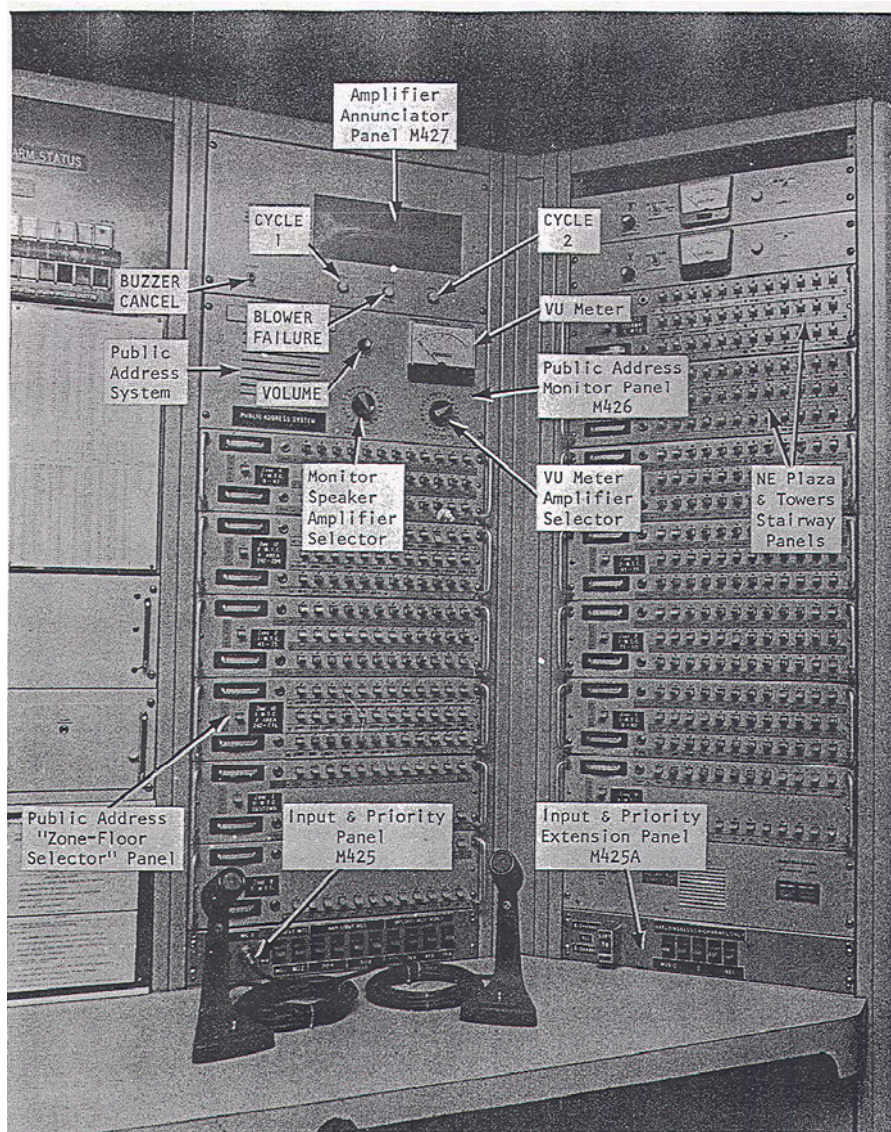

Source: PANYNJ 1986. Reproduced with permission of The Port Authority of New York and New Jersey.

Figure 3–14. Public address console.

3.5 SPRINKLER WATERFLOW ALARM SYSTEM

The Sprinkler Waterflow Alarm System in the Subgrades of the WTC is the subject of this subsection (PANYNJ 1986). It contains descriptions of the major components of the system and their functions.

The function of the Sprinkler Waterflow Alarm System was to alert personnel in the Police Security Room on Level B1 that sprinkler water was flowing. The system included supervisory alarms that monitored water level conditions in the fire reserve tanks and the condition of the pumps associated with the Sprinkler System.

3.5.1 Component Descriptions

Sprinkler Waterflow Detectors

A sprinkler waterflow detector is an electromechanical device that initiates an electrical alarm when there is a flow of water through a sprinkler pipe. A typical installation is shown in Fig. 3–15. The sprinkler waterflow detector terminal cabinet shown in this figure connected the waterflow detector to the sprinkler alarm annunciator in the old HVAC computer room on Level B4 (see Fig. 3–16).

The sprinkler waterflow detector was equipped with a vane that protruded into the sprinkler pipe. The pressure of the water flowing through the pipe moved the vane, which in turn caused a microswitch to close. This closing transmitted an alarm to the sprinkler alarm annunciator panel in the old HVAC computer room, and a flag dropped down, indicating the zone in which the water was flowing.

The sprinkler alarm annunciator panel that sent a signal to the multiplex computer in the Police Security Room on Level B1, where the alarm was printed out on a teletype unit. A mechanical maintenance person was then dispatched to the old HVAC computer room to determine which flag on the annunciator panel had dropped down. Then he or she reported the location of the flow to the Police Security Room. Police and operations personnel then investigated the reason for the alarm.

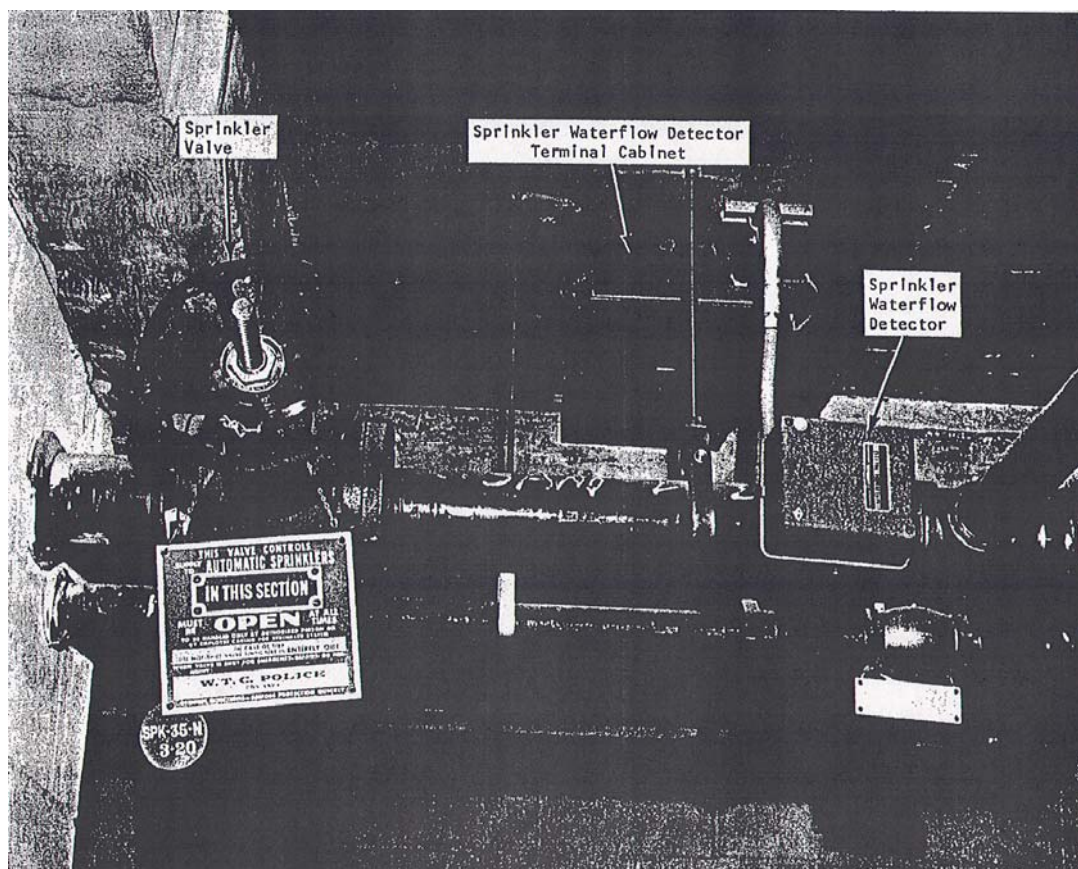

Source: PANYNJ 1986. Reproduced with permission of The Port Authority of New York and New Jersey.

Figure 3–15. Sprinkler waterflow detector installation.

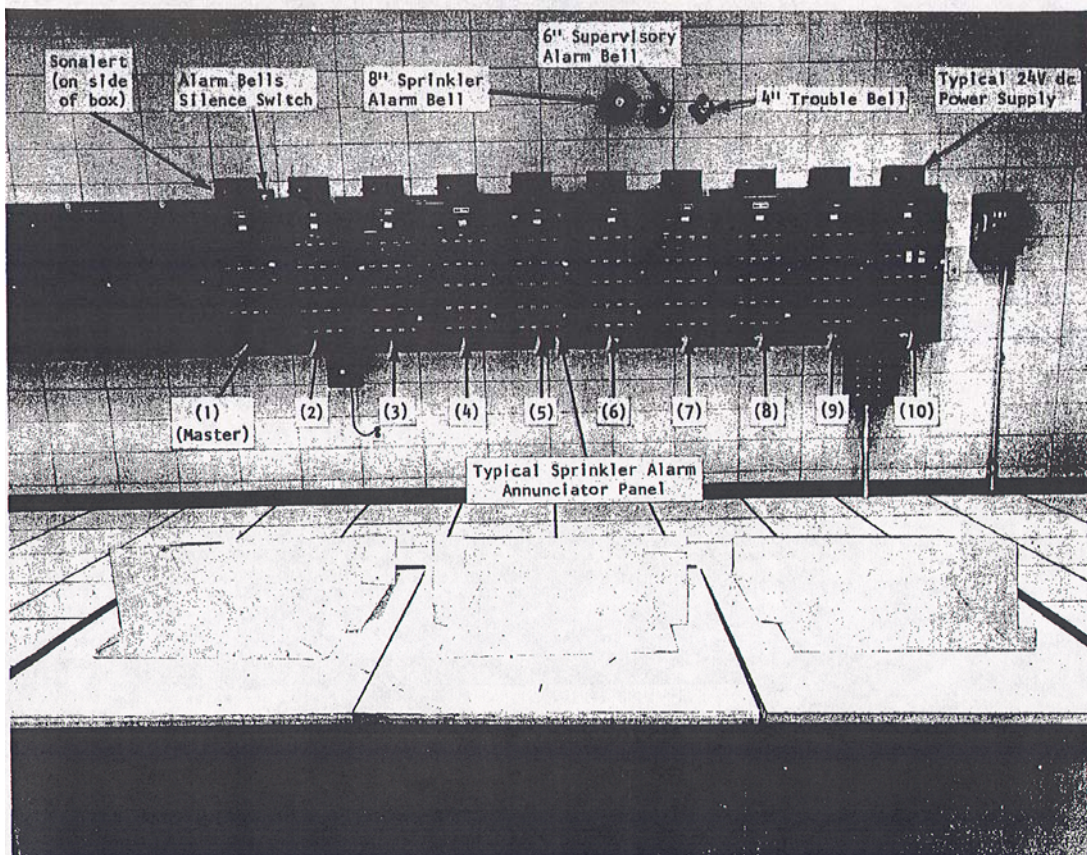

Source: PANYNJ 1986. Reproduced with permission of The Port Authority of New York and New Jersey.

Figure 3–16. Sprinkler alarm annunciator in HVAC computer room.

Sprinkler Alarm Annunciator Panel

The sprinkler alarm annunciator panel was in the old HVAC computer room on Level B4. The panel contained sprinkler waterflow and supervisory alarms. The supervisory alarms indicated when and if the conditions of certain equipment in the sprinkler system were abnormal. The conditions monitored were: the level of water in the fire reserve tanks; and the operating status of the fire standpipe pumps, the sprinkler fire pumps, the combination sprinkler/fire standpipe pumps, and the sprinkler jockey pump.

3.6 STANDPIPE FIRELINE COMMUNICATION SYSTEM

The Standpipe Fireline Communication System in the WTC is dealt with in this subsection (PANYNJ 1986). Included are verbal descriptions of the system, photos of the equipment utilized, and block diagrams of the entire system.

The Standpipe Fireline Communication System in the WTC was provided for firefighter use during operation of the standpipe system. This system included two-way telephone communications.

The Standpipe Fireline Communication System was a selective-ringing, common-talking system that was comprised of a Master, Submasters, and Outlying Stations, with a power supply, and an amplifier. The

Master and Submaster Stations were in the pump rooms, MERs, main lobbies, skylobbies, and near roof manifolds of the Standpipe Fireline System. The Outlying Stations were generally near standpipe hose racks (see Figs. 3-17 and 3-18).

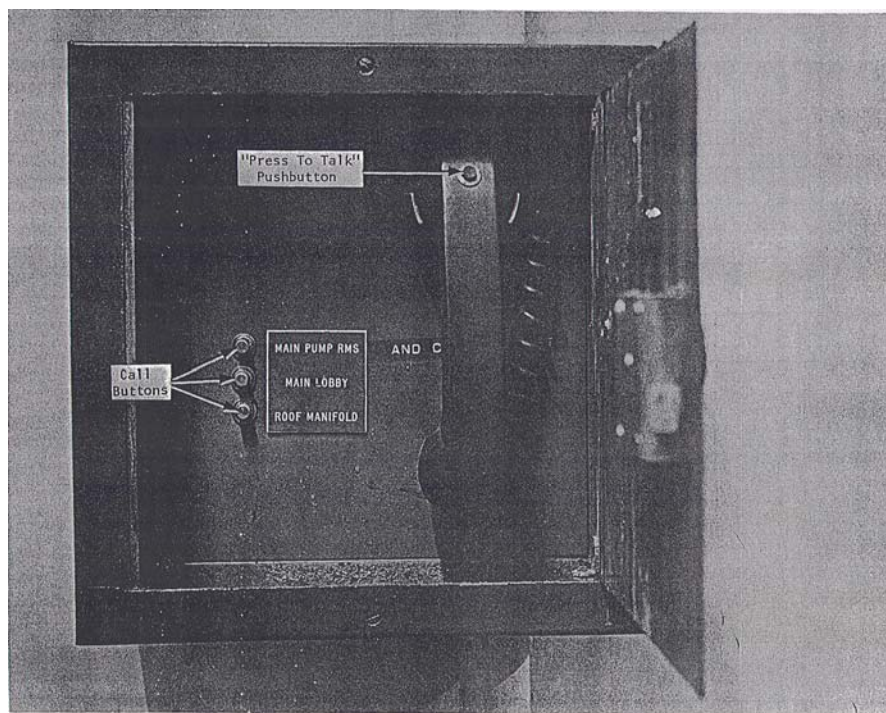

Source: PANYNJ 1986. Reproduced with permission of The Port Authority of New York and New Jersey.

Figure 3-17. Outlying station interior view.

In WTC 1 and WTC 2, the Outlying Stations were in the B staircase, on the odd-numbered floors 1 through 109, and Elevations 294 ft, 264 ft, and 242 ft (see Fig. 3-18). In the WTC 4 and 5, Outlying Stations were in the staircases, on the Concourse (Elevation 310 ft), Elevation 285 ft 6 in., Elevation 266 ft, and Elevation 246 ft.

Outlying Stations

Each Outlying Station was either surface-mounted or flush-mounted, depending upon its location. The station consisted of a red telephone handset with a press-to-talk pushbutton and three call buttons (see Fig. 3-17). By means of the three call buttons a firefighter could signal certain designated Master and Submaster Stations. The Outlying Stations were not capable of receiving signals other than voice (PANYNJ 1986).

All Outlying Stations were equipped with a Fire Department of the City of New York (FDNY or Fire Department) paracentric lock which was to be locked at all times, except when the phone was in use (see Fig. 3-18). The lock could be opened only by personnel of the World Trade Fire Safety Coordinator's Office, World Trade electrical maintenance personnel, and the Fire Department (PANYNJ 1986).

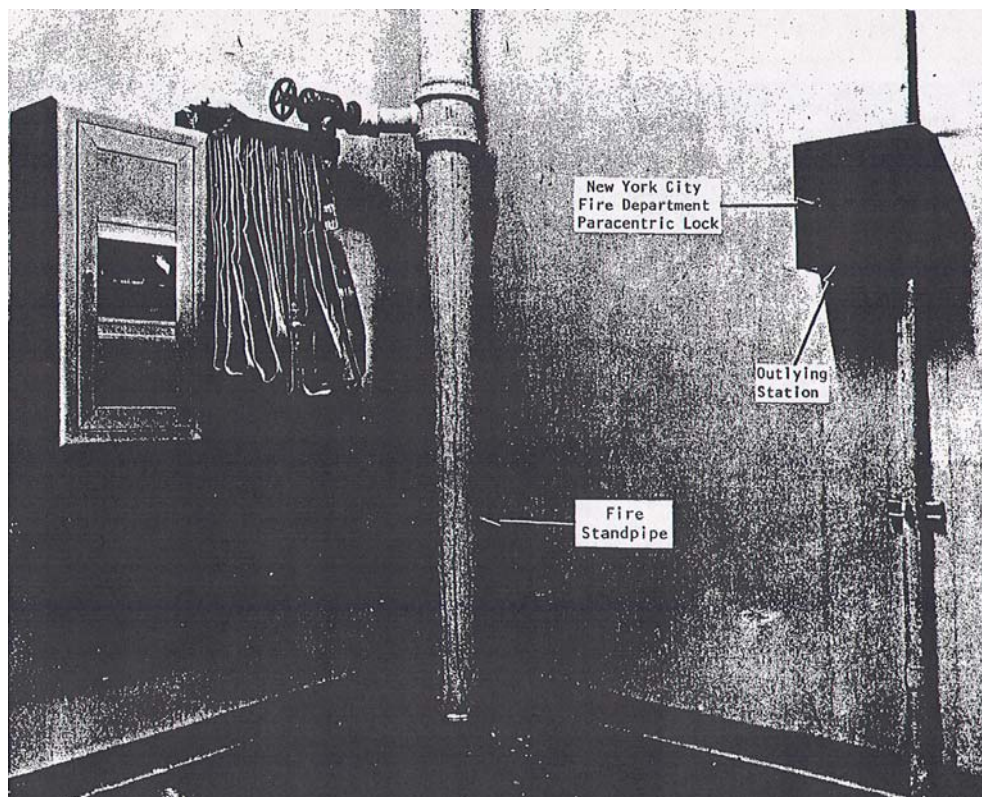

Source: PANYNJ 1986. Reproduced with permission of The Port Authority of New York and New Jersey.

Figure 3–18. Outlying station of Standpipe Fireline Communication System.

The pre-1993 Fire Alarm System in the WTC included the various Smoke Detection and Alarm Systems and the All-Purpose Public Address System used to make announcements during fire drills or an actual fire emergency (PANYNJ 1986).

3.7 COMPARISON OF THE PRE-1993 AND POST-1993 FIRE ALARM SYSTEMS

This section provides a comparison of the fire alarm systems in place in the WTC complex before the 1993 bombing with those installed after the bombing and in place on September 11, 2001 (PANYNJ 1986; Drucker 2001; Drucker 2004; SafirRosetti 2002).

3.7.1 General

The American Multiplex Digital Computer and Console was a fire alarm and communication system engineered and built specifically for the WTC. Although it was state-of-art at time of construction, fire protection technology had changed significantly in the decades since the original installation. Performance based codes and standards had consolidated the fire detection, monitoring, control, and communication systems that were originally separate packages into one system sharing common functions and capabilities. The Port Authority did upgrade the MER fire alarm protection with the installation of a microprocessor controlled, addressable Pyrotronics XL3 system in each MER, which was

monitored by a CXL Command Center monitor in the OCC. The XL3 fire alarm system was the predecessor to the Siemens Pyrotronics MXL-V system installed post-1993.

3.7.2 Fire Command Station Pre-1993

The original OCC on the B-1 Sub-Grade Level provided a single, central fire alarm monitoring and control station for both the WTC 1 and WTC 2 towers. The fire alarm system consisted of multiple components, from differing manufacturers, configured into a single-seat monitoring station for:

- Detection, monitoring, and control of fire alarm devices.
- Alarm and voice broadcast by floor.
- Floor intercom communication.
- Fire Department notification.

The original American Multiplex system was engineered and produced exclusively for the WTC towers. The manual interface for monitoring and control of the fire alarm system consisted of visual indicators, switches, audible notification appliances, alpha-numeric printouts, phones, and microphones.

The CXL Command Center monitor provided the status of the alarm and malfunction conditions for the XL3 fire alarm panels located in the mechanical equipment rooms.

3.7.3 Fire Command Station Post-1993

Each tower, WTC 1 and WTC 2, had its own Fire Command Station, which contained the building's fire alarm system. Also, there were redundant fire alarm system monitoring and controls for each building's system in the OCC. As another layer of redundancy, since the WTC 2 Fire Command Station was located above the OCC, a second remote fire alarm system for WTC 2 was located in the WTC 1 Fire Command Station.

The post-1993 fire alarm system in the Fire Command Stations and OCC were manufactured, tested, and produced as a single, integrated fire alarm system providing multiple, inter-relating functions. The system was modular in design and could be modified or expanded as needed to provide:

- Detection, monitoring, and control of fire alarm devices.
- Alarm and voice broadcast by floor.
- Floor intercom communication.
- Fire Department notification.

The system consisted of off-the-shelf technology that was produced by the manufacturer for large fire alarm projects. The manual interface for monitoring and controlling the system consisted of a Network Command Center monitor and computer keyboard, which provided alpha-numeric detail of the fire alarm

status and condition. Additional visual indicators, switches, phones, and microphone were available for interfacing with the differing fire alarm functions.

The major differences between the pre-1993 fire alarm system monitoring and control capabilities found at the main operator's monitoring station and the post-1993 fire alarm system were the level of information provided about the status of the system and the ergonomic interface improvements offered by the newer system. Since the newer system was a microprocessor based, addressable fire alarm system, it was able to provide an alpha-numeric accounting of its status in both an alarm and abnormal functioning condition. This was critical since any large system serving a facility with multiple tenants is going to experience constant changes in configuration. These dynamic changes to the system require controls by policy, procedure, and system. The system could provide immediate feedback on where changes to the system were made through internal condition monitoring capabilities that provided an alpha-numeric indication at the fire alarm monitoring stations. The system condition reports provide the general or specific location of the induced faults that occurred during any system modification. These indications allowed the system operator to remotely monitor if and when the system's status had returned to normal, or if further actions were needed to return the system to normal.

The newer fire alarm system also offered a single-seat interface for all of its monitoring functions. The Network Command Center monitor and keyboard offered the operator the ability to interrogate the status of any alarm or fault condition and provided a historic log of past alarms or changes to the overall status of the system. The control of the warden and Standpipe Fireline communications systems was accomplished at the panels within the Fire Command Station, along with the control of the emergency voice alarm communication (EVAC) capability. The newer system provided more information and better monitoring and control through fewer visual indicators, switches, phones, and microphones.

3.7.4 Base Building Fire Alarm System Pre-1993

In addition to the main Digital Computer and Console in the Operations Control Center located in B-1 Sub-Grade Level Operations Control Center, the pre-1993 fire alarm system consisted of American Multiplex RMT located on every third floor. The RMT monitored Pyrotronics CR-7 Equipment, which was connected to the non-addressable smoke detectors, tenant proprietary systems, and waterflow switches through the remote sprinkler alarm annunciator located on the B4 level.

In addition, Pryrotronics XL3 smoke detector systems, with addressable type heads, were installed in the mechanical equipment rooms of both WTC 1 and WTC 2, and connected via a CXL Communication Device to a console in the OCC.

3.7.5 Base Building Fire Alarm System Post-1993

The post-1993 Base Building Fire Alarm System consisted of a head-end MXL-V fire alarm panel connected to five MXL-VR remote panels, and the remote MXL-VR panels monitored and controlled up to eight PSR panels. The PSR panels monitored and controlled fire alarm circuits for typically three floors.

The major differences between the old and new systems were the consolidation of all fire alarm monitoring and controls into a single system and the survivability characteristics that were selected and

engineered into the newer system. The pre-1993 fire alarm system consisted of components made by different manufacturers consolidated into a single system out of necessity because all the functions and capabilities required from the system was not available from a single manufacturer at the time. Although documentation was not available to verify operator and maintenance personnel experiences with the system, historically, separate systems and components that are consolidated into a uniquely configured system can provide continual challenges for maintenance and modifications.

The improved survivability characteristic of the newer system resided in both the equipment and the architecture of the system circuits. The distribution of the system's intelligence among the five remote panels allowed each remote panel to act independently to follow its programmed sequence of operations during a fire emergency. As an example, if the remote MXL-VR panel's communication was severed from the head-end or other remote panels, it would switch to a communication degrade mode and initiate audible and visual alarms throughout its protection area upon activation of an alarm device. This capability was also true for the PSR panels, which would switch to a degrade mode and initiate a visual and audible alarm signal within its protection area if it lost communication with its remote MXL-VR when receiving an alarm indication from a monitored device. In addition to the degrade operation mode, the PSR panels contained a back-up tone generator in case they lost the main audio signal circuit that was controlled by the Head-end MXL-V panel. This allowed the PSR panels, which contained the audio amplifiers and speaker circuits, to broadcast a general alarm signal when it received an alarm indication from any connected panel or its own monitored devices. The signal would not contain a voice message since all messages originated from the head-end MXL-V panel, but could provide a general alarm signal for occupant notification.

Additional survivability was obtained from the newer system with the installation of Class A circuits when available, which provided redundant paths for the transmission of signals and information for the detection, monitoring, control, and EVAC communication. Class A circuits were not available for the Warden and Standpipe Fireline systems. The redundant paths allowed the system to switch to an alternate communication path if the cable or equipment was damaged. The extent of damage that could be sustained while maintaining communication over the redundant paths was dependent on the type of circuit. The Class A, Style 7 Signaling Line Circuit, used for detection, monitoring, and control, was able to sustain communication while experiencing a wire-to-wire fault while the Class A, Style Z Notification Appliance Circuit that provided the EVAC signal from the head-end panel was not able to sustain communication with a wire-to-wire short. Although there was a disparity in circuit performance, the circuits used provided the best survivability characteristics available for the cable used.

3.7.6 Detection, Monitoring, and Control Devices Pre-1993

Documentation shows that the original fire alarm system provided general detection, monitoring, and control capabilities for the following:

- Return air smoke detectors located on each floor.
- Elevator lobby detectors that initiated elevator recall.
- Monitoring of the sprinkler water flow and tamper switches.
- Monitoring of tenant fire alarm system.

- Monitoring of the air handling unit's smoke detectors in the mechanical equipment rooms. The activated smoke detector would shut down the associated air handling unit.
- Manual break glass station would automatically activate an alarm on the floor of occurrence if the system operator did not respond within 20 s.

The detection, monitoring, and control were performed by devices and equipment from different manufacturers.

3.7.7 Detection Monitoring, and Control Devices Post-1993

The replacement fire alarm system provided detection, monitoring, and control capabilities for the following:

- Return air smoke detectors located on each floor which would shut down its associated air handling unit upon alarm.
- Smoke detector protection for the electrical, telephone, and fire alarm closets.
- Elevator lobby detectors that initiated elevator recall.
- Monitoring of the tenant fire alarm panels.
- Monitoring of the sprinkler water flow and tamper switches.
- Monitoring of the air handling unit's smoke detectors in the mechanical equipment rooms. The activated smoke detector would shut down the associated air handling unit. The activation of a second detector within each air handling unit would activate the unit's sprinkler deluge system.
- Manual stations located at every stairway entrance.

The main differences between the old and newer systems were the additional information and control capability provided by the newer system and the inability of the newer system to provide automatic occupant notification upon receipt of an alarm signal.

The newer system's detection, monitoring, and control capabilities were programmable and addressable. The activation of any addressable device would provide the system operator with a detailed message for identification. The device could also be programmed to control any associated addressable device that had control functions. These capabilities provided for the automatic activation and control of life safety function without human intervention.

The automatic control capability was not incorporated into the automatic notification of the occupants upon device activation. The system had the capability to provide automatic notification based upon programmed parameters, but this capability was not implemented.

3.7.8 Notification Appliance Devices Pre-1993

Documentation shows that the original fire alarm system provided occupant notification through the following:

- Speakers in the corridors.
- Speakers in the stairways.
- Speakers in the core area of the ventilation ducts.

The PA was provided with two channels of sound transmission. Voice announcements were made via the microphones either at the Control Center Console at the Police Desk on Level B1 or at the ESPs in the Main Lobbies or Skylobbies. There was one ESP in the Main Lobby of each tower and one ESP on the 44th and 78th floor skylobbies of each tower. From these locations announcements could be made to any floor of the WTC.

3.7.9 Notification Appliance Devices Post-1993

The newer fire alarm system provided occupant notification through:

- Speakers in all floor areas spaced to insure intelligibility and audibility.
- Strobes in all common areas that were area spaced and rated to ensure adequate illumination for notification of the hearing impaired.

The major differences between the pre-and post-1993 occupant notification capabilities were the engineered spacing of the newer system to ensure performance, the inclusion of visual strobes on the new system for the hearing impaired, and the ability of the newer system to broadcast voice commands from selected telephones.

The design of the newer system required that minimum audibility and intelligibility performance requirements were met in the spacing and locations of the speakers. This effort was performed to ensure that the alarm and voice announcements could be heard and understood throughout the building.

The newer system also provided visual strobe alarms that were spaced and located in the common use areas. The location and spacing of the strobes was engineered to provide the illumination required to notify persons with hearing impairments.

The newer fire alarm system also had the ability to allow the head-end system operator the ability to patch selected telephones into the EVAC system for remote voice broadcasts.

3.7.10 Warden and Standpipe Fireline Communication System Pre-1993

Documentation shows that the original fire alarm system provided occupant and firefighter two-way communication through an Executone intercom system for the occupants, and a Standpipe Fireline

Communication System for firefighter use. The devices for the separate communication systems were as follows:

- Occupant communication was provided with break glass stations located on every floor.
- Firefighter communication was provided with phone stations located near standpipe hose racks on each floor, in the fire pump rooms, the MERs, the main lobbies, the skylobbies, and near the roof standpipe manifolds.

The Executive intercom system was monitored and controlled at the OCC. The system was also monitored by a reel-to-reel tape recorder that kept a history of all communications over the intercom system.

The Standpipe Fireline Communication System was a selective-ringing, common-talking system that comprised Master, Submaster, and Outlying Stations; a power supply; and an amplifier. The Master and Submaster Stations were in the pump rooms, the MERs, the main lobbies, the skylobbies, and near the roof manifolds of the standpipe system. The Outlying Stations were generally near standpipe hose racks.

3.7.11 Warden and Standpipe Fireline Communications System Post-1993

The newer fire alarm system provided warden and firefighter communications through:

- Floor Warden telephone stations located on each floor.
- Standpipe fireline communication stations located near standpipe hose racks on each floor, in the fire pump rooms, the MERs, and near the roof standpipe manifolds.

The major differences between the pre-and post-1993 arrangements were the use of a single communication system for both the warden and the firefighter communication in the new system and the ability of the newer system to broadcast voice messages over the speakers.

This page intentionally left blank.

Chapter 4

FIRE ALARM SYSTEM PERFORMANCE REQUIREMENTS

As an interstate compact under the U.S. Constitution, the Port Authority was not subjected to any state or local building codes. The World Trade Center (WTC) was designed in accordance with the New York City Building and Fire Prevention Codes of 1968 in effect at the time of the building's construction. The Port Authority of New York and New Jersey's (PANYNJ or Port Authority) objective was to adhere to or exceed local code requirements.

In addition to the New York City building codes, the Port Authority relied on nationally recognized fire safety standards published by the American National Standards Institute and the National Fire Protection Association, as well as internal protocols established with fire officials in the city. Two noteworthy protocols included the "Protocol for Periodic Joint Port Authority/ Fire Department of New York Inspections of Port Authority New York City Facilities" of 1988 and the "WTC/ FDNY Joint Protocol for Inspectional Activity at the World Trade Center Complex" of 1986. The Port Authority maintained a positive working relationship with The Fire Department of the City of New York (FDNY or Fire Department) through these protocols that allowed the Fire Department access for inspections and evaluation of life safety and fire protection systems at the complex. The Fire Department was provided with the authority to issue advisory reports resulting from their inspections, which the Port Authority could consider on a voluntary basis (NIST NCSTAR 1-1H¹).

This spirit of cooperation was reciprocated with the New York City Department of Buildings and formally acknowledged in a Memorandum of Understanding between the two parties after the explosion at the towers on November 3, 1993. The most current edition of the New York City Building Code was identified as the design basis for any construction after November 1993.

The applicable building codes document the requirements to achieve the minimum acceptable level of safety for occupants. The building codes in effect are the primary source for determining what safety features will be installed in a building. Many building codes include referenced standards that address how various aspects of the building and systems are to be installed and constructed in order to provide the intended levels of safety. Another regulatory element that comes into play is product safety standards. Building codes and installation standards require the use of products that have been investigated to verify that they perform as intended without causing a safety hazard. Product safety standards and listing agencies, such as Underwriters Laboratories, Inc., provide vehicles for evaluating the performance of products from a safety perspective. Verification and testing of products for public safety ensures that the level of safety established by the building codes for the building design, and implemented per recognized installation standards during the building's construction, will be accomplished through the products' performance.

¹ This reference is to one of the companion documents from this Investigation. A list of these documents appears in the Preface to this report.

4.1 GENERAL FIRE ALARM REQUIREMENTS

The fundamental purpose of a fire alarm system is to detect fires, notify occupants, and summon emergency responders. The applicable building and fire codes establish basic requirements for the types of devices and functions required for a specific facility based on its use. The actual layout and interaction with other building systems are established by the designers as part of the fire protection plan for a facility. The goals and objectives of the fire alarm system are usually defined by a Fire Protection Engineer as they relate to the fire protection needs of the facility.

4.2 FIRE COMMAND STATION FIRE ALARM SYSTEM FUNCTIONS

The fire alarm system within the WTC offered multiple functions to enhance the overall life safety features within the buildings. The primary monitoring and control of the fire alarm system was performed at the Fire Command Station (FCS) within each building. The life safety functions performed by the FCSs were (PANYNJ 1999a; NIST NCSTAR 1-1H):

- An audible alarm signal upon an alarm condition or system malfunction.
- Manual control of the emergency voice and alarm communication capability. Voice or alarm notification could be selected by individual floor, group of floors, or throughout the building.
- A means to silence the audible alarm signals when the loud speakers were in use and for activating the audible alarm system automatically when use of the loud speakers was terminated.
- Manual acknowledgment of the alarm or system fault condition through an alpha/numeric display and keyboard.
- A two-way telephone system for the firefighters with the capability to make announcements over the emergency voice and alarm communication system.
- A two-way telephone system for the floor warden stations, mechanical control center, and air-handling control rooms.
- A means to manually transmit a fire alarm signal to the Fire Department.
- Means for testing the display, alarms, and connection to the Fire Department.

4.3 FIRE ALARM SYSTEM FUNCTIONS

The detection and notification functions were performed throughout the building by the fire alarm system. The life safety functions performed by the fire alarm system were (PANYNJ 1999a; NIST NCSTAR 1-1H):

- Emergency voice and alarm speakers for audible notification and communication in all areas within the building.

- Strobes to provide visual alarm indications for the hearing impaired.
- Two-way firefighter telephone communication system.
- Two-way floor warden telephone communication system.
- Two-way maintenance telephone communication located at the remote fire alarm panel locations.
- Automatic smoke detection that would provide an alarm signal at the FCS upon activation.
- Monitor the fire sprinkler system for water flow or disabled performance conditions that would alarm at the FCS upon activation.
- Manual stations for occupant activation that would alarm at the FCS upon activation.
- Monitoring of independent fire alarm systems installed by individual tenants that would annunciate their alarm condition at the FCS.
- Automatically notify the Fire Department upon fire alarm activation.

4.4 FIRE ALARM SYSTEM INSTALLATION CRITERIA

The overall performance of the fire alarm system is dependent on the installation of the equipment and devices meeting prescribed standards. Installation standards originate from the manufacturer, design criteria, and local requirements. A synopsis of the major equipment installation standards as they relate to their performance included (PANYNJ 1999a; NIST NCSTAR 1-1H):

- Speakers located to ensure their operation would be heard clearly above ambient noise level.
- The voice loudspeaker system was required to ensure 50 percent of the system would remain operable throughout the building in the event 50 percent became inoperable.
- Visual alarm devices were required in common use spaces.
- Automatic smoke detectors were required in the mechanical rooms, electrical switch gear rooms, electric and telephone closets.
- Automatic smoke detectors installed at the return air ducts serving each floor were required to shut down its corresponding air handling unit upon the detector's activation.
- Automatic smoke detectors at each elevator landing for recalling elevators upon detector activation.
- At least one manual fire alarm station was required to be installed in each story in the path of escape. No point on a floor could be more than two hundred feet from the nearest station.
- Floor warden telephone stations were required to be located between required stairways.

- Firefighter telephones were required near the main standpipe in the stairway on each floor, and within the sprinkler water tank and fire pump rooms.
- FCS was required to be located in the lobby of the building.
- The fire alarm wire criteria required a minimum size and type that would not support flame.
- Riser cable and its branches were not required to be installed in conduits or raceways if not exposed to public view.
- A terminal connection box for the wiring served a maximum of five floors above and five floors below the terminal box.

Chapter 5

FIRE ALARM SYSTEM DESIGN, EQUIPMENT, INSTALLATION, AND PERFORMANCE CRITERIA

The magnitude, size, and scope of the World Trade Center (WTC) fire alarm retrofit project rivaled any effort performed by the fire protection industry. It was estimated that over 10,000 initiating devices (smoke detectors, manual pull stations, waterflow indicators, etc.), with 30,000 notification appliances (speakers and strobes), supported by over 700,000 ft of conduit and 5 million ft of wire was installed in the WTC as part of the fire alarm system retrofit project (Mizrahi). Project development documentation found and analyzed was focused on the system's architecture and performance. No documentation was found that indicated cost was a factor in obtaining the WTC's fire protection goals.

Before the original fire alarm system operation was fully restored after the 1993 bombing, The Port Authority of New York and New Jersey (PANYNJ or Port Authority) Engineering Department began to explore the WTC's fire detection and alarm system's goals, and how to incorporate these requirements into a replacement system. Based upon its findings, the Port Authority Engineering Department initiated a fire alarm retrofit project, which was developed from the following objectives (PANYNJ 1998):

1. Identify the type and extent of fire detection, communication, notification, and monitoring capabilities required.
2. Select the fire alarm technology to support the size of the WTC complex (approximately 12,000,000 ft²), with the capability to interface with the existing fire alarm systems. All the equipment was required to be New York City (NYC) BSA/MEA approved, and was required to be readily available for initial purchase and spare parts.
3. Determine the size, type, and number of equipment, devices, and hardware needed for the fire alarm infrastructure. Identify location and space for the infrastructure.
4. Determine how to interface the new system with the existing fire alarm systems and their components.
5. Develop standards, guidelines, and specifications for the design of the retrofit fire alarm system.
6. Develop standards, guidelines, and specifications for the installation of the fire alarm system.
7. Institute maintenance procedures to ensure the availability and performance of the fire alarm system.

Although documentation of the decision-making processes or directives defining the WTC fire alarm protection goals were not located, the overall design development, installation, and maintenance of the system indicates that it was the intention of the Port Authority to meet or exceed all local code and American with Disabilities Act requirements as interpreted by the Chief Engineer of the WTC. If the Port

Authority believed that it was in the best interest of the WTC and its tenants to vary from the code requirements due to operations and/or other features of the fire alarm system, the Port Authority would obtain agreement or approval from the Fire Department and/or Department of Buildings as per the Memorandum of Understanding signed between the Port Authority and the Department of Buildings (Semah 1996).

5.1 SYSTEM DESIGN AND INSTALLATION CRITERIA FOR WTC 1 AND WTC 2

The magnitude and size of the fire alarm system was reflective of the protected building's size and large number of people that occupied the building on any given day. To control a project of this size, specific design criteria were developed based upon the system's performance objectives and fire protection goals. The design criteria designated type, models, location, and performance of the fire alarm control and monitoring equipment, supporting hardware, and fire alarm devices. Procedures were also developed to monitor and track the project's progress. The phased project approach and its criteria allowed the transfer of the original system's fundamental monitoring, controls, and communication capabilities to be transferred to the replacement system during the first phase of the project, and allowed new or revised fire alarm devices to be put into service as soon as they were functional during succeeding phases.

The coordination of multiple projects involving the installation of the system and changes during tenant fit outs required close coordination between the Port Authority, equipment supplier, architects, engineers, and contractors. The equipment supplier, Siemens, provided the fire alarm equipment, system engineering, technical support, and overall project management liaison. Project coordination meetings were held on a weekly basis with the Port Authority Engineering, Risk Management, Operations, and Contractor Representatives to coordinate all project activities. Additionally, daily conference calls were made with the Port Authority Maintenance Supervisor to review the effect of all ongoing projects on the overall operational status of the system. Tracking ongoing projects was documented through (Drucker 2001):

1. System inspection records and Fire Department logs.
2. System maintenance records.
3. Updates to core capital record for changes.
4. Design compliance review functions.
5. System reacceptance testing records.

5.1.1 System Arrangement

The baseline for defining the fire alarm system's performance was derived from the objective to meet Local Law 76 as it related to existing high-rise office buildings over 100 ft tall. The Fire Alarm and Communication System for a Class "E" building was required to contain the following components to monitor and annunciate the status of its devices and initiate an appropriate response (PANYNJ 1999a; NIST NCSTAR 1-1H):

1. Fire Command Station (FCS) located in the lobby of the building on the entrance floor.
2. Manual Fire Alarm Stations provided in each story along the path of escape with additional stations installed so that the maximum travel distance between stations would not exceed 200 ft.
3. Speakers located on all floors, stairways, and elevators² that can be operated in the FCS.
4. Visual Alarm Devices (strobes) are to be provided in spaces used by people having physical disabilities. The Americans with Disabilities Act Accessibility Guidelines for Buildings and Facilities (ADAAG) was used as the criteria for determining what areas require visual alarm devices.
5. Floor Warden Stations on each floor that provided two-way communication with the Fire Command Station.
6. Standpipe Fire Line Telephone System with communication stations provided at FCS, each floor near the standpipe riser, gravity tank rooms, and fire pump rooms.
7. Associated monitoring and controls:
 - a. Smoke and heat detection
 - b. Sprinkler monitoring
 - c. Status of air handling systems

5.1.2 Design Criteria

The fire alarm system was considered a single part of a comprehensive approach for the WTC's fire protection needs. As such, quality controls were maintained through quality assurance analysis, standards, and criteria for the design and installation of the replacement fire alarm replacement system. This was an ongoing effort that introduced changes as studies or experiences identified areas requiring improvement or new technology offered enhanced system performance (Drucker 1994; WTC Engineering Dept 1994; Syska & Hennessy 1996; Drucker 1996; Semah 1996; Menno 1998; Drucker 1998; Semah 1998; Barbella 1999; Boyle 1999; Bonacci 1999; Drucker 1999; Drucker 1999).

5.1.3 Speaker Audibility and Intelligibility

The Port Authority performed an in-depth analysis on speaker intelligibility and audibility for the WTC (see Fig. 5-1). The intent of the analysis was to develop a speaker location guideline that would ensure an acceptable level of intelligibility (message clarity) and audibility (loud enough to be heard).

² Elevator speaker communication controlled by a separate elevator system.

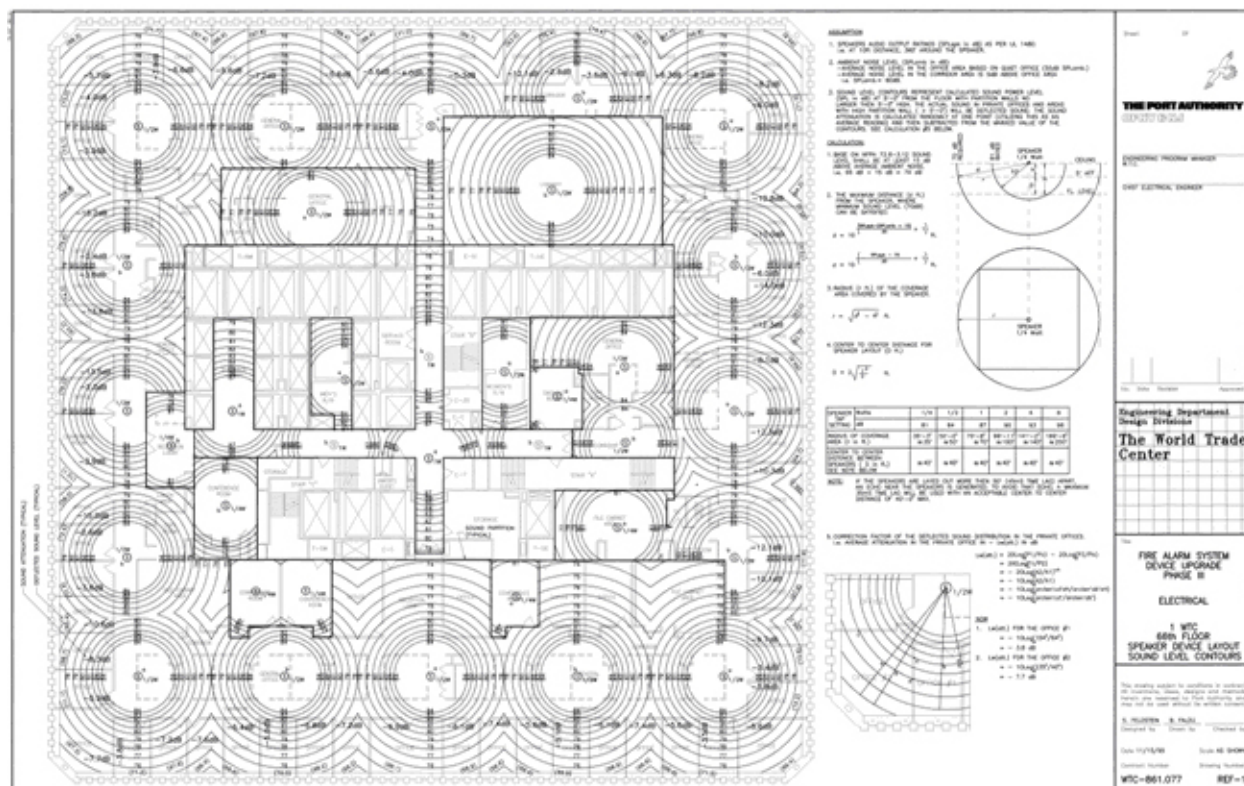

Source: PANYNJ. Reproduced with permission of The Port Authority of New York and New Jersey.

Figure 5–1. Speaker intelligibility and audibility performance drawing.

5.1.4 Design Guidelines

The “MANDATED Fire Alarm Guidelines” (WTC 1999) was the basis for the installation of new equipment and changes during new tenant fit out. The guideline provides a comprehensive approach that includes:

1. An introduction providing a general description of the WTC.
2. Terms, definitions, and general information required for the design and installation.
3. Fire alarm system backbone system architecture that describes the core system interface equipment and hardware.
4. Intent, location, and requirements of the distributed fire alarm interface cabinets. The guideline included typical cabinet configurations and connections.
5. Fire detection and interface device design criteria for device locations, installation, and connections.
6. Audio and visual notification appliance design criteria for device locations, installation, and connections. The notification appliance information was required to include its audio power in watts and luminous intensity in candela requirements for the speakers and strobes.

7. Fire alarm riser/one line diagram criteria requiring a diagrammatic format for each interface cabinet, circuit, raceway, detection device type, and notification appliance type.
8. Circuit performance criteria with forms for documenting test procedures, results, and verification.
9. Contractor tie-in and pretest checklist to document that the design and installation procedures have been followed.
10. Acceptance testing forms to document and assure the performance of the fire alarm monitoring, detection, and notification devices.
11. Project summary that reviews the deliverables required for the fire alarm installation through design, installation, acceptance, as-built documentation, and final project close out.

The standardized design concept was reinforced in the “Tenant Construction Review Manual” that provided the technical criteria for all architectural and engineering consultants in connection with construction work undertaken by the WTC tenants (Engineering Dept 1997).

5.1.5 Design Approach

A standardized approach for the design and installation of the tower fire alarm equipment and devices was developed by subdividing a typical floor plate into a core and quadrants (see Fig. 5–2). The intent was to set quality control standards with typical requirements and locations for common equipment, devices, and circuits within an assigned area.

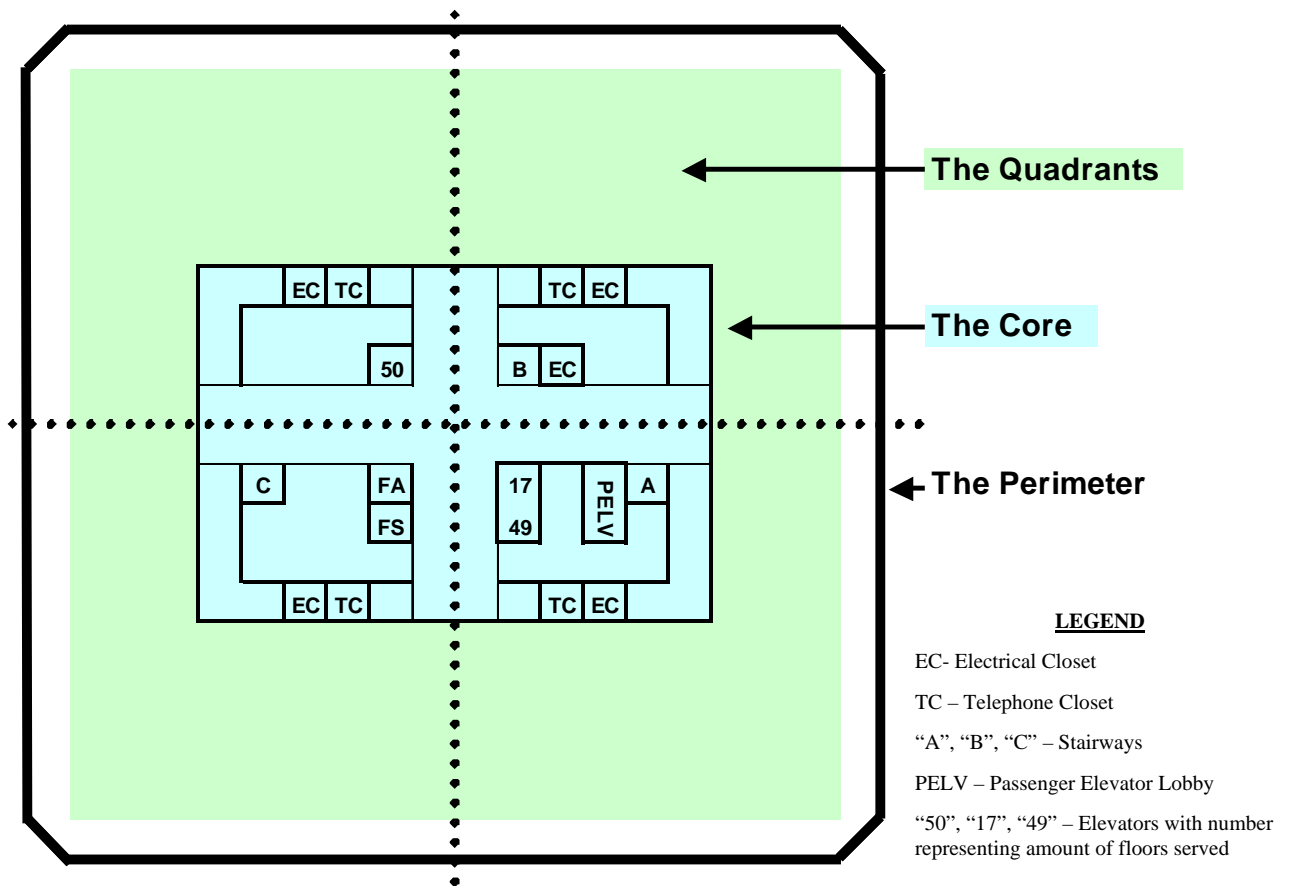

Source: Drucker 2001.

Figure 5–2. Core and quadrants.

5.1.6 Typical Fire Alarm Equipment and Device Locations

Specific areas within the typical floor template were designated for the fire alarm control equipment, initiating devices, and communication equipment (see Fig. 5-3).

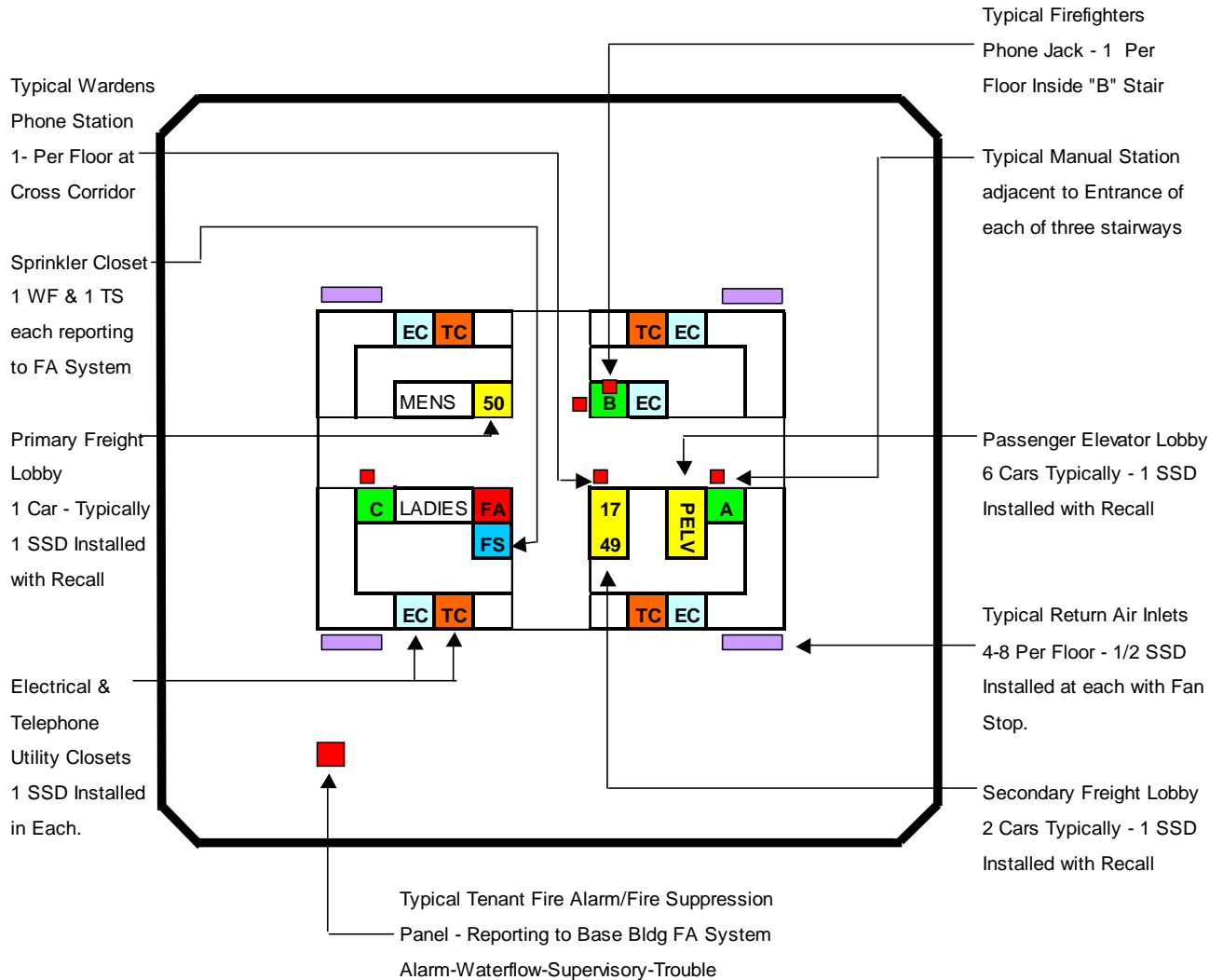

Source: Drucker 2001.

Figure 5-3. Standard locations for fire alarm equipment and devices.

5.1.7 Typical Fire Alarm Cabinet Connections

The Core Fire Alarm Closets and Core Fire Sprinkler Closets were designated locations for fire alarm interface panels and cabinets, which supported and distributed the system’s monitoring, control, and communication circuits. The Terminal Strip Cabinet (TSC) was located in the fire alarm closet when a remote fire alarm panel was present, and located in the fire sprinkler closets on floors without remote fire alarm panels (see Figs. 5-4 and 5-5). The TSC supported the telephone, speaker, and strobe notification appliance circuits. The typical drawings for the TSC included the cable connection details to maintain quality control.

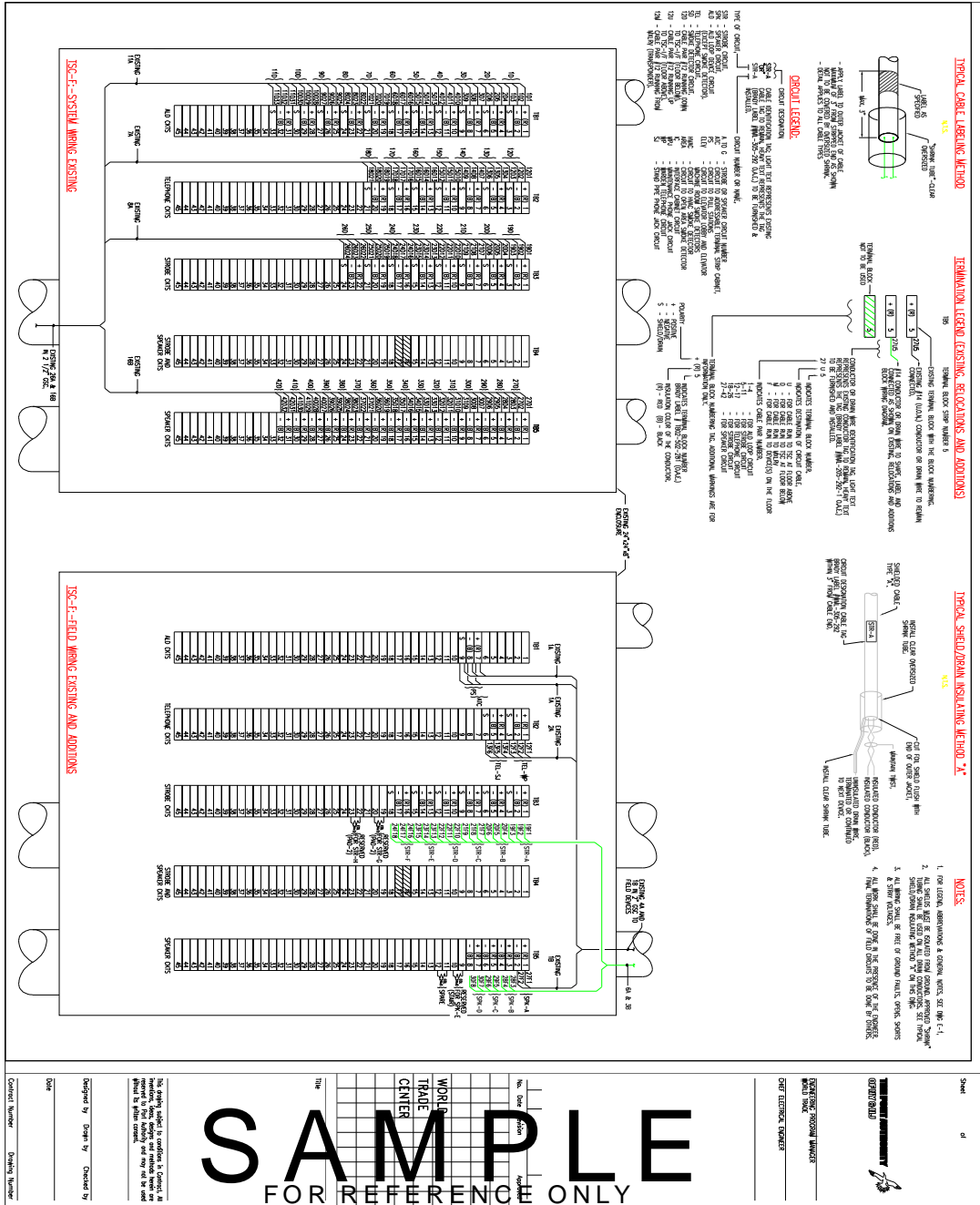

Source: Reproduced with permission of The Port Authority of New York and New Jersey.

Figure 5–4. Standard configuration for Terminal Strip Cabinet

The ALD Terminal Cabinets (ATC) were located in the core fire sprinkler closets. ALD is the fire alarm manufacturer’s abbreviation for “Analog Loop Driver,” which are the circuits for the fire alarm monitoring and control devices. The typical drawing included device and circuit connection details.

5.1.8 Typical Fire Alarm Installation Detail

Typical drawings were developed to provide guidance on the installation criteria for the devices to meet tolerances required by code and the manufacturer (see Figs. 5–6 and 5–7).

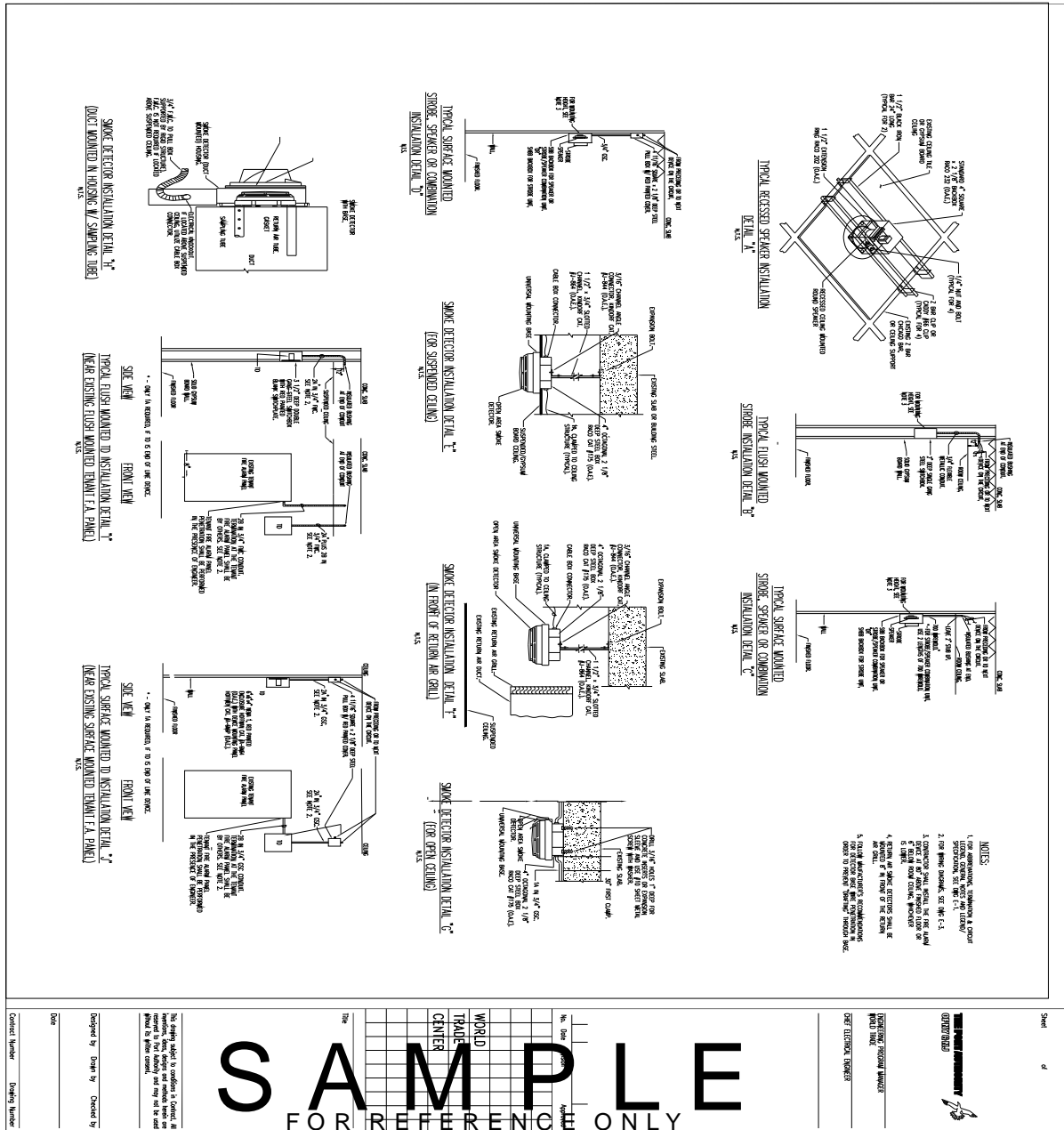

Source: Reproduced with permission of The Port Authority of New York and New Jersey.

Figure 5–6. Standard location for fire alarm devices.

5.1.9 Typical Fire Alarm Circuit Routing Criteria

A schematic diagram was included in the design criteria, providing a standard for the layout of the fire detection and notification circuits (see Fig. 5–8). The circuit configurations were developed to meet code requirements and to improve overall survivability of the system’s functions within the protected area. The intent of the circuit configurations was to limit the effects from a single circuit loss to performance degradation of its function within the protected area, without causing a catastrophic failure.

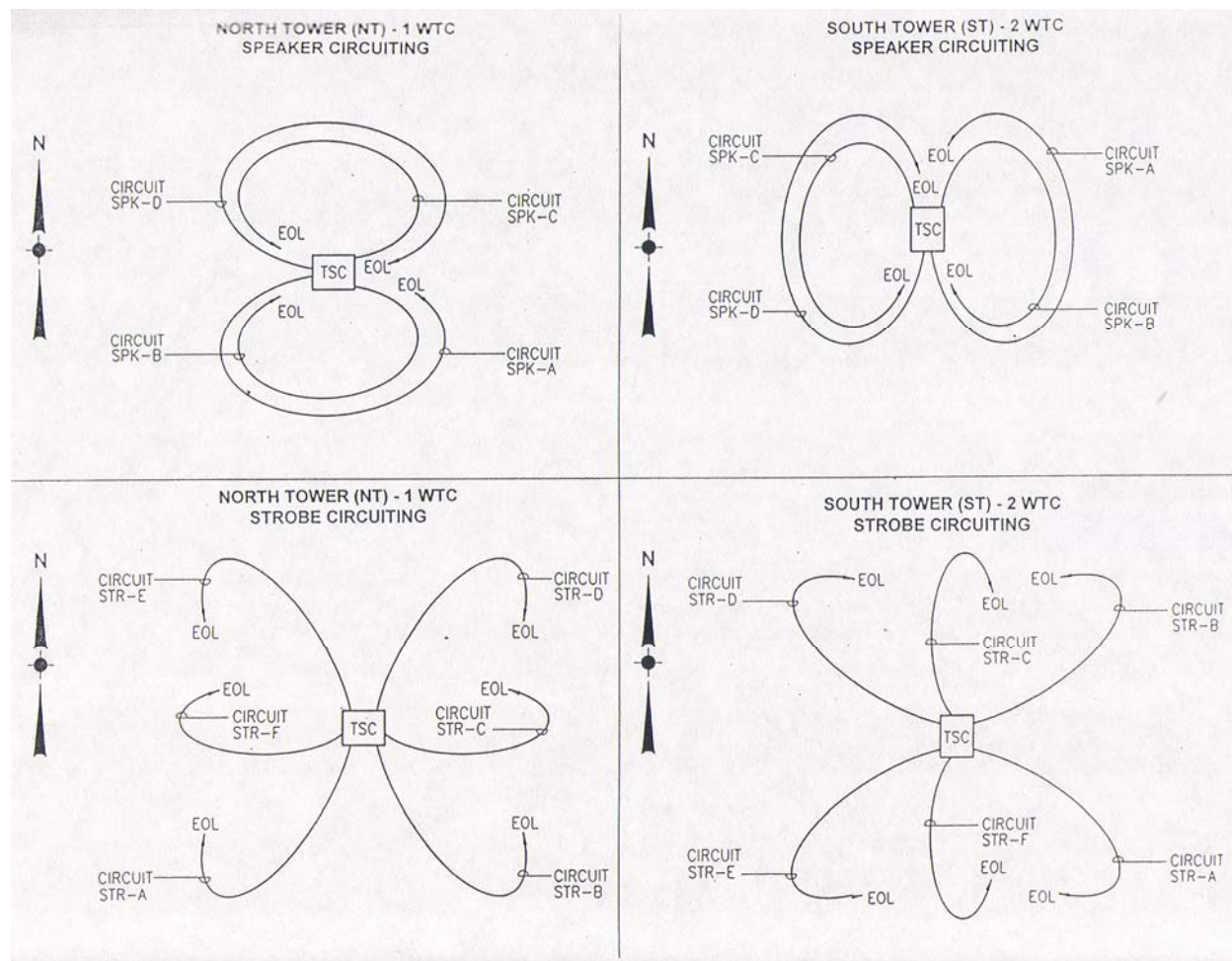

Source: Reproduced with permission of The Port Authority of New York and New Jersey.

Figure 5–8. Standard routing for fire alarm circuit.

5.1.10 Typical Fire Alarm Device Design Detail

Typical drawings were developed to provide a submittal format for architects, engineers, and contractors. The intent was to set a standard on what information was required, and how the information was to be presented on a drawing submitted for approval. Typical drawings were developed for the fire detection, speaker, and strobe design submittals (see Figs. 5–9 to 5–11).

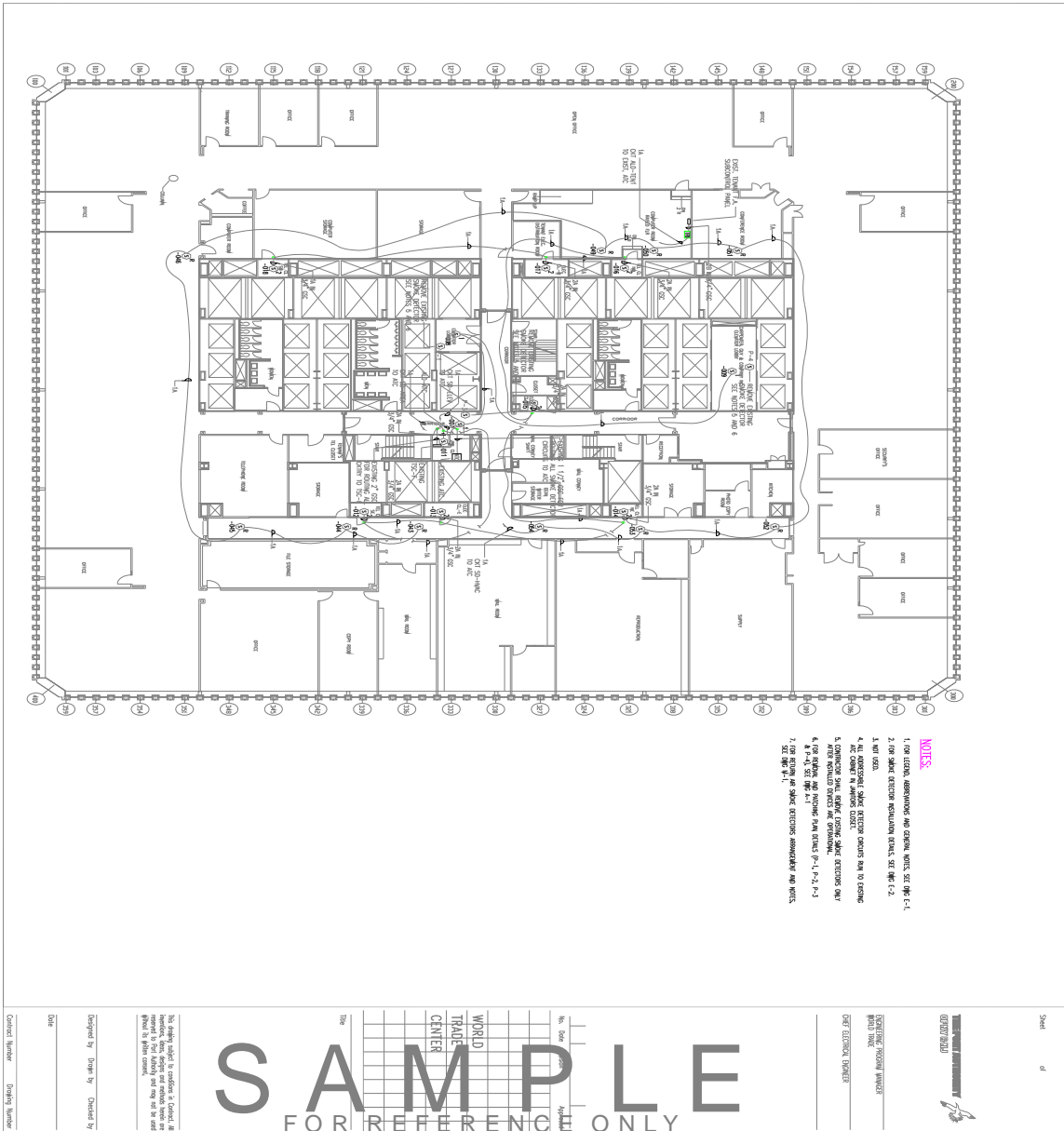

Source: Reproduced with permission of The Port Authority of New York and New Jersey.
Figure 5–9. Standard layout for fire alarm detection.

5.1.11 Typical Fire Alarm Device Riser Detail

Typical fire alarm riser drawings were developed to provide a standard on what information was required and how the proposed system installation or expansion would interface with or affect the existing system's performance and capabilities (see Fig. 5–12).

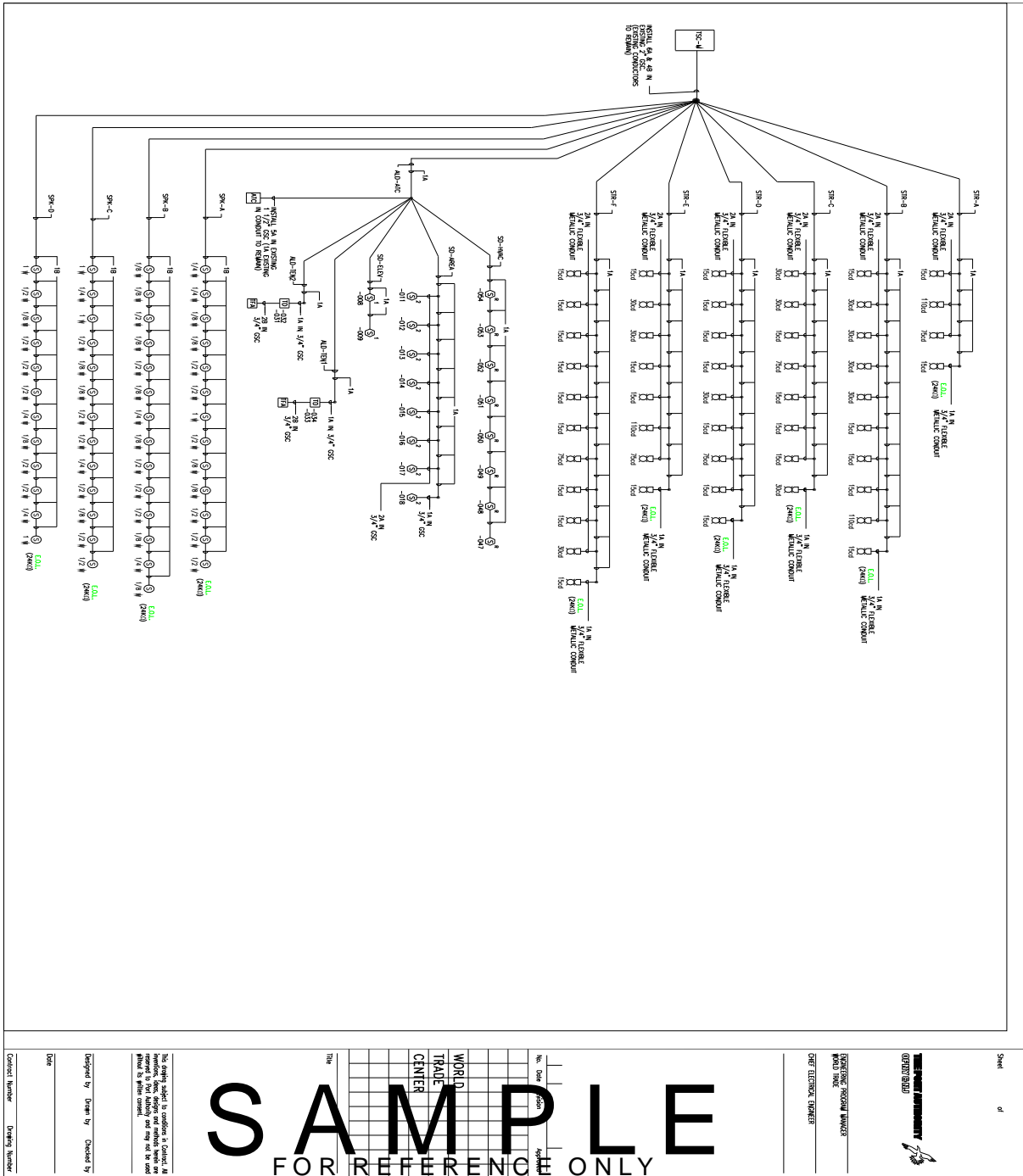

Source: Reproduced with permission of The Port Authority of New York and New Jersey.

Figure 5–12. Standard detail for fire alarm riser.

5.1.12 Installation Acceptance Testing and Commissioning Procedures

The installation of the approved fire alarm design required the contractor to perform specific quality control procedures. Since any system modifications would affect both the building occupants and the contractor’s safety, specific testing and acceptance practices were developed to address these issues (see Fig. 5–13).

CERBERUS PYROTRONICS SPECIAL PROJECTS / WTC	----- OPERATIONS BEST PRACTICES -----	CG 19367.00	Drucker 06/01/98
Subject: Fire Alarm System Acceptance Testing - Phase III BBFAS Engineering Projects - Part 1			
WHAT:	This document describes the Acceptance Test Procedures that are to be followed when performing this work on Smoke Detectors, Sub System TRI's, Speakers, Strobes, Pull Stations Warden Phones, Standpipe & Maintenance Jacks		
WHY:	A standardized procedure insures that the required testing is performed efficiently, effectively and in accordance with project requirements. It also insures that coordination activities and safety precautions are followed.		
HOW:	<ol style="list-style-type: none"> 1) PA Manager to assign Acceptance Test dates and times based on successful connection of and pretesting of fire alarm equipment. 2) Building Fire Safety Director, Elevator Starters and Operators must be advised of the Work Area, Time of and Scope of Work being Performed. 3) A SD Maintenance Log Worksheet shall be started for each EMR/MGR. The Worksheet must be filled out completely. 4) (2) Sets of Ladders, Cleaning and Testing Agents, Meters, Hand Tools and Velocity Meter are required. 5) Entry Into EMR/MGR must be in the company of an elevator mechanic. Two Way Radio communications with the accompanying Elevator Mechanic must be maintained at all times. 6) Prior to entry into, around or above Elevator Machinery the site shall be examined for personal hazards. Where it is found that electrical equipment, motors, cables, or other UNPROTECTED hazards that could cause injury or death are encountered the work in these areas shall be performed only after the Elevator Mechanic has shutdown and locked out the equipment. 7) Only proper Ladders, Stairs or Access Ramps shall be utilized to reach equipment. Work shall not be performed using motors, electrical panels, conduits, pipes, etc for support. 8) Encounters with Hazardous Substances, including but not limited to ACM shall be reported immediately to the CPY Project Manager. Work shall not proceed in these areas. 9) Each Detector shall be maintained in accordance with the Contract Specifications (Para. 2.) and RCNY-17-06. Actual Function Testing of Elevator Recall shall occur. 10) The following procedure shall apply for each unit: <ol style="list-style-type: none"> a.) Lead Tech Directs operation - makes appropriate notification calls. b.) One Tech works on Casing SD, One Tech works on Duct SD. c.) Perform Detector Cleaning and Examination. Duct Detector Velocity (V) to be Checked. d.) Duct Detector sampling tubes are to be checked & cleaned via Access Doors if V Readings are Low. e.) Trip Duct Smoke Detector - Verify Fan Shutdown - Reset -Restart Fan f.) Trip Casing Smoke Detector - Verify Fan Shutdown - DO NOT RESET f.) Trip Duct Smoke Detector - Verify Deluge Sprinkler Operation - Reset - Restart Fan. 11) System Functions shall be documented, unexpected or failed operation shall be noted. Detectors found water damaged, wet or otherwise contaminated with other than normal dusts and dirt shall be reported. Duct Detector Velocity reading shall be recorded. 12) System(s) Shall be returned to Fully Operational Status and or the condition found prior to the work. Verify with Mechanical Mechanic that Deluge Valve is Reset. 		
SUBJECT TO CHANGE PENDING CONTRACT AND OR PROCEDURAL REVISIONS			

Source: PANYNJ 1999a. Reproduced with permission of The Port Authority of New York and New Jersey.

Figure 5–13. New work acceptance best practices.

5.1.13 Quality and Performance Assurance Forms

New fire alarm work was required to be tested to ensure its compliance with adopted performance criteria. Quality assurance forms were developed to provide testing accountability (see Figs. 5–14 and 5–15).

The Port Authority of NY & NJ	WTC BASE BUILDING FIRE ALARM SYSTEM CONTRACTOR TIE-IN & PRE-TEST CHECKLIST	Electrical Operations and Maintenance	
<p>This checklist is designed to assist the contractor, to reduce construction delays, accelerate tenant occupancy, increase productivity and reduce delivered costs. The items listed are required to be completed prior to the scheduling of the WTC Base Building Fire Alarm System Tie-In and Pre-Testing.</p>			
<p>Please direct completed forms, scheduling and technical requests to Mr Ray Simonetti, at 212-435-5005 >>>> 24 Hour Advance Notice Required Prior to Tie-In and Pre Testing Scheduling <<<<</p>			
1	TENANT Name: _____ (PRINT)		
2	BLDG Location: <u>1WTC</u> 2 WTC 4WTC 5WTC CONCOURSE SUBGRADE (CIRCLE)		
3	BLDG Floor: _____ (PRINT)		
4	CONTRACTOR Name: _____ (PRINT)		
5	Wire Test Results - Submitted, Corrected as Required and Approved.	<input type="checkbox"/> Completed <input type="checkbox"/> Not Applicable	
6	Speaker/Strobe Wiring in TSC, ALD Wiring in ATC Ready for Tie-In.	<input type="checkbox"/> Completed <input type="checkbox"/> Not Applicable	
7	Speakers set at selected power levels and installed. <i>(Power setting ,in Watts, per Design)</i>	<input type="checkbox"/> Completed <input type="checkbox"/> Not Applicable	
8	Strobes match selected power levels and installed. <i>(Power setting ,in Candela, per Design)</i>	<input type="checkbox"/> Completed <input type="checkbox"/> Not Applicable	
9	Smoke Detectors programmed, labelled and installed.	<input type="checkbox"/> Completed <input type="checkbox"/> Not Applicable	
10	TRI Interfaces programmed, labelled and installed.	<input type="checkbox"/> Completed <input type="checkbox"/> Not Applicable	
11	Waterflow and Tamper Devices Installed and Operational.	<input type="checkbox"/> Completed <input type="checkbox"/> Not Applicable	
12	Tenant SubSystem(s) Installed and Operational.	<input type="checkbox"/> Completed <input type="checkbox"/> Not Applicable	
13	Fire Alarm Drawings - As Installed including all Changes. <i>(2 Sets - Submitted in Advance to PA O&M Electrical Supervisor)</i>	<input type="checkbox"/> Completed <input type="checkbox"/> Not Applicable	
14	Architect, Engineer, and General Contractor concur with Status.	<input type="checkbox"/> Completed <input type="checkbox"/> Not Applicable	
15	I certify that the WTC Base Building Fire Alarm Work required for the referenced Tenant Project has been completed in its entirety compliant with the Plans and Specifications submitted and Released, and I am ready for the System Pretest	<table border="1"> <tr> <td data-bbox="938 1499 1224 1598"> FAX COMPLETED FORMS TO: Mr Ray Simonetti WTC O&M - Electrical 1-212-435-5717 </td> </tr> </table>	FAX COMPLETED FORMS TO: Mr Ray Simonetti WTC O&M - Electrical 1-212-435-5717
FAX COMPLETED FORMS TO: Mr Ray Simonetti WTC O&M - Electrical 1-212-435-5717			
16	Signed: _____		
17	Date: _____		

SCD/SPWTC Rev3. 02/17/1999

Source: PANYNJ 1999a. Reproduced with permission of The Port Authority of New York and New Jersey.

Figure 5–14. Contractor tie-in and pre-test checklist.

5.1.14 Fire Command Station Performance Standard

The FCS for Class E high-rise office buildings over 100 ft tall is required to be located in the lobby of the building on the entrance floor and contains the following components to monitor and annunciate the status of the fire alarm system and its devices (PANYNJ 1999a; PANYNJ 1999b; Drucker 2001; Drucker 2004):

1. An audible alarm signal.
2. Emergency voice and alarm communication capability.
3. Means for silencing the audible alarm signals when the loud speakers are in use and for activating the audible alarm system automatically when use of the loud speakers is terminated.
4. A means to control the alarm sounding devices on any floor throughout the building.
5. A manually reset information display to indicate the floor where the alarm was activated.
6. Manual controls and display lamps to include on/off condition of air-handling systems.
7. A Standpipe Fire Line Telephone system for the firefighters with the capability to make announcements over the emergency voice and alarm communication system.
8. A two-way communication system connected to a designated floor warden station on each floor, the mechanical control center, elevators, air-handling control rooms, and elevator machine rooms.
9. Means to manually transmit a fire alarm signal to the Fire Department via a central station of a franchised operating company.
10. Means for testing the display, alarms, and connection to the central station.

5.1.15 Fire Command Station Equipment

After the 1993 bombing, the Port Authority built FCS for WTC 1 and WTC 2 based upon the Building Code of New York code requirements as the baseline for design and performance (see Figs. 5–16 and 5–17). A master MXL-V and primary Network Command Center (NCC) for each building was installed in the building's FCS as the fire alarm system's main monitoring and control center. The master MXL-V consisted of numerous panels, with each providing specific functions required to meet the FCS performance criteria. The master fire alarm panels located in the FCS contained an alpha/numeric annunciator with switches for acknowledging the system alarms and for controlling system functions. These functions were also monitored, displayed, and controlled by the NCC located within the FCS. Additional panels contained the microphone and controls for the emergency voice/alarm communication (EVAC) system and controls for the firefighter and warden telephone communication systems.

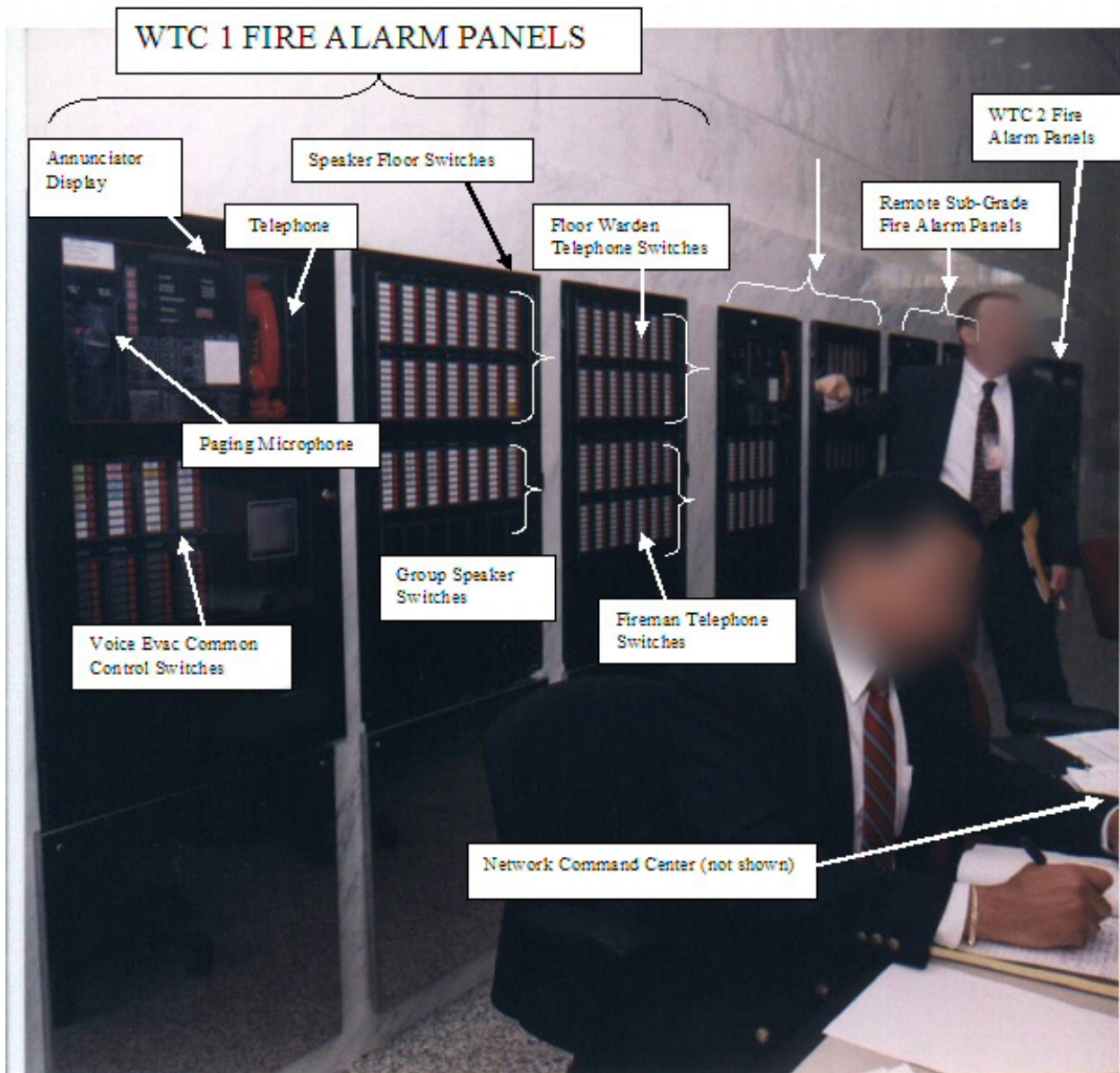

Source: PANYNJ 2000. Reproduced with permission of The Port Authority of New York and New Jersey.

Figure 5-16. WTC 1 fire command station.



Source: PANYNJ 2000. Reproduced with permission of The Port Authority of New York and New Jersey.

Figure 5–17. WTC 2 fire command station.

5.1.16 Fire Command Station Design, Installation, and Operation

Although the history of the overall fire alarm design development indicates that there was detailed design documentation for the FCS architecture and fire alarm equipment layout, only limited pictures and schematic representations were located. The pictures and documentation indicate that the FCS was designed in a professional manner, met the adopted performance requirements for the systems installed, and was ergonomically designed for monitoring and control of the equipment by operating personnel.

The majority of fire alarm monitoring and control operation was performed at the NCC monitor. The NCC monitor provided an interactive display of the system's status and the options available to the responding operator in relation to the system's status. In addition to the NCC monitor, the fire alarm panels mounted on the FCS wall provided the following controls (PANYNJ 1999a; PANYNJ 1999b; Drucker 2001; Drucker 2004):

1. Manual controls and alphanumeric display that provided NCC redundancy.
2. The microphone for the emergency voice alarm communication system.

3. The control switches and status indicators for the emergency voice alarm communication system.
4. The telephone handset for the floor warden and firefighter telephones.
5. The control switches and status indicators for the floor warden and firefighter telephone system.

5.2 BASE BUILDING FIRE ALARM EQUIPMENT PERFORMANCE STANDARD

The backbone of the WTC 1 and WTC 2 fire alarm system was designated as the “Base Building Fire Alarm System” (BBFAS). The BBFAS provided the basic support structure and interface components for the fire alarm system throughout each building. The NYC Code provided the baseline performance standards for the equipment, electrical power, and wiring requirements for the design and installation of the BBFAS equipment (PANYNJ 1999a; PANYNJ 1999b; Drucker 2001; Drucker 2004; NIST NCSTAR 1-1H).

5.2.1 Base Building Fire Alarm System Equipment

The FCS monitored and controlled the BBFAS. The system chosen as the BBFAS was the Cerberus Pyrotronics MXL-V integrated fire detection system with EVAC capabilities. The original BBFAS contained a MXL-V master panel located in the FCS and 34 slave PSR (Pyrotronics Remote Transponder) panels distributed throughout each tower. Although the system architecture introduced survivability improvements through the introduction of redundant signal transmission network risers and command centers, the centralized intelligence of each tower’s system resided in the FCS’s MXL-V master panel. The manufacturer developed an improved network configuration that would improve survivability and overall signal processing time through the introduction of an additional distributed intelligence network. The installation of the new distributed intelligence network was performed during the end of Phase II and Phase III. The system improvement caused minimal impact to the overall planning and execution of ongoing projects since the original BBFAS installation included spare cables that were used for the new signal transmission network.

The final system architecture consisted of the main head-end MXL-V panel located at the FCS; distributed MXL-VR remote control panels which were located within both towers on levels B6, 7, 41, 75, and 108; and PSR panels that were monitored and controlled by the MXL-VR panels (see, for example, Fig. 5–18). The MXL-VR panels provided localized intelligence and acted as the master over the PSR slave panels. Each master MXL-VR monitored and controlled up to 8 PSR slave panels, which were located every third floor (typically) and contained system transponders, amplifiers, terminal cabinets, and interface points that provided access to the BBFAS platform. Each PSR provided the central monitoring and control point for fire alarm cabinets located on their respective floors.



Source: PANYNJ 2000. Reproduced with permission of The Port Authority of New York and New Jersey.

Figure 5–18. Mechanical equipment room (MER) MXL-VR location.

The FCS head-end MXL-V fire alarm panel provided the main point of processing and control for the fire alarm functions. Although the NCCs provided a video interface for the fire alarm system operator, the actual operation, control and monitoring of device status, identity, and network communications was performed by the MXL-V panel. The configuration of the MXL-V modules that provided these capabilities consisted of:

- The main board for information processing (model MMB-1)
- The display and keyboard for redundant status display and control (model MKB-2)
- Floor warden and firefighter telephone master module (TMM-1)
- Emergency voice alarm microphone master module (MMM-1)
- 40 switch and status light modules for the control of the emergency voice alarm communication system and telephone system. Each module contained 8 individual switches with status lights, for a total of 320 separate control zones (VSM-1).
- Audio control module for alarm tone generation and overall control of the voice alarm transmission signals (ACM-1)
- XNET Style 7 Network Interface module (NIM-1R)
- Power supply rated at 6.5 amps (MPS-6)
- Battery back-up supply (BP-61)

The MXL-VR remote panels distributed through the towers provided intelligence and gateways for signal transmission and action between the MXL-V panels. They also provided a remote location to interrogate the system status when performing system maintenance and repairs. The configuration of the MXL-VR modules that provided these capabilities consisted of:

- The main board for information processing (model MMB-1)
- The display and keyboard for redundant status display and control (model MKB-2)
- XNET Style 7 Network Interface module (NIM-1R)
- Style 7 Communication Modules (NET-7)
- Power supply rated at 6.5 amps (MPS-6)
- Battery back-up supply (BP-61)

The PSR slave panels performed the main fire alarm device monitoring and control functions for each building's fire alarm system. To perform these functions, each PSR contained power supplies, battery chargers, audio amplifiers, network transponder, initiating, notification, control, and communication modules. The typical PSR panel configuration consisted of:

- Three 10 Amp Power Supplies (model PS-35)
 - Power Supply #1 was for the strobes on the floor above the fire alarm closet.
 - Power Supply #2 was for the strobes on the floor containing the fire alarm closet.
 - Power Supply #3 was for the strobes on the floor below the fire alarm closet.
- Battery backup for 4 h standby followed by 15 min of alarm capability.
- Three 100 watt amplifiers (model EL-410D)
 - Amplifier #1 was for Channel #1 – page/alert messaging.
 - Amplifier #2 was for Channel #2 – EVAC messaging.
 - Amplifier #3 was for backup – standby function.
- Backup tone generator (BTC-1)
- Four addressable initiating device loops – one loop for each floor with one spare (ALD-2)
- 16 audible speaker circuits – five circuits for each floor with one spare (ZC2-8B-70)
- 24 visual strobe circuits - six circuits for each floor with six spare (ZC1-8B-25)
- Fire Fighters and Warden Telephone Communication (ZCT-8B)

A fire alarm closet was designed to support the new fire alarm equipment and hardware, and was built into the existing sprinkler closets (see Fig. 5–19). The designated fire alarm closet contained the PSR, supporting an amplifier cabinet, a TSC, and Network Terminal Cabinet (NTC). The fire alarm closets were only built (typically) on every third floor. The NTC supported the vertical signal transmission network risers interconnecting the distributed MXL-VR and PSR panels.



Source: PANYNJ 2000. Reproduced with permission of The Port Authority of New York and New Jersey.

Figure 5–19. Fire alarm closet with PSR location.

Additional TSC cabinets were installed on each floor and were interfaced through a PSR. Each TSC supported four speaker circuits and six strobe circuits for each floor.

The PSR also supported an Interface Cabinet (IC), located in the electrical closet containing the Remote Monitoring Transponder (RMT) for monitoring the existing American Multiplex fire alarm system during the transition to the new MXL-V fire alarm system. The electrical closet also contained the emergency power panel that supplied power to the MXL-VR, PSR, and amplifier cabinets through a dedicated fused circuit.

In addition, the PSR supported Addressable Terminal Cabinets (ATC), which were located on each floor. The ATC cabinets provided one device loop sub-divided into five branch circuits (see Fig. 5–20). Each branch circuit was assigned specific monitoring functions:

1. ELEV Branch – Smoke detectors for passenger and freight elevators.
2. AREA Branch – Open area smoke detectors for the phone, electrical, and fire alarm closets
3. HVAC Branch – Ventilation smoke detectors for plenums and ducts.

4. TEN1 Branch – Dedicated branch for monitoring any tenant subsystems.
5. TEN2 Branch – Dedicated branch for monitoring tenant subsystems.

The floors without a fire alarm closet had their ATC and TSC located in the sprinkler closet on that floor.

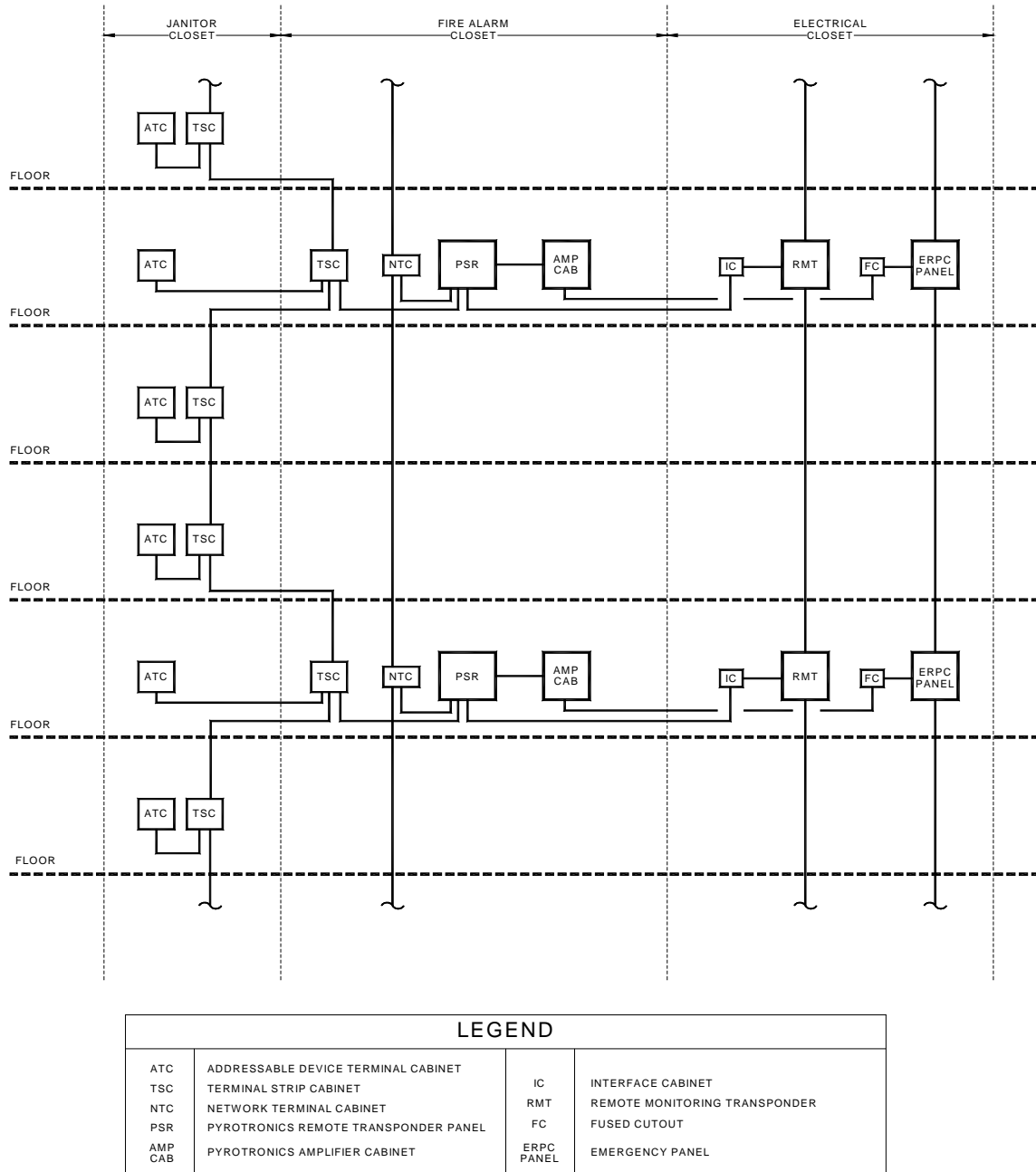

Figure 5–20. Fire alarm closet with PSR location.

5.2.2 Base Building Fire Alarm System Design, Installation, and Operation

The Port Authority standardized the design and criteria, equipment configuration and layout, which was critical to maintain quality controls. Equipment locations were also standardized, and dedicated fire alarm closets were constructed to support the equipment. The overall design, equipment layout, and installation of the BBFAS were consistent with applicable codes and standards.

The FCS NCCs provided the main point of control for the BBFAS equipment. The MXL-VR panels located at floor levels B6, 7, 41, 75, and 108 provided a redundant point of monitoring and control of the individual MXL-VR and its slave PSR panels. The FCSs provided the main point of monitoring for all alarms and fault conditions, with the MXL-VR providing remote status query capability.

5.3 SYSTEM NETWORK TRANSMISSION PATHS PERFORMANCE STANDARDS

The WTC 1 and WTC 2 fire alarm systems consisted of numerous panels located throughout each tower. The interconnection of the distributed panels within each tower was accomplished through multiple vertical system network transmission paths commonly referred to as risers. The NYC Code provided the baseline performance for the risers. This baseline was very limited in scope, as are all model building codes when regulating the performance and installation of risers.

A fire alarm riser may contain numerous transmission paths for multiple functions associated with the system. The WTC 1 and WTC 2 system risers controlled functional capabilities that included:

1. Fire detection
2. Life safety system monitoring
3. Life safety system control
4. Occupant notification
5. Floor warden and firefighter telephone communication capability
6. System display and control of the fire alarm system

The type and performance of fire alarm transmission paths within a riser are not dictated by building codes or standards. The type and performance of the communication paths are defined by the National Fire Alarm Code (NFAC) (NFPA 72), and their capabilities verified through testing by nationally recognized laboratories. The NFAC, which is developed by the National Fire Protection Association (NFPA) through a consensus standards development process approved by the American National Standards Institute, provides performance requirements for multiple types of transmission paths for accomplishing the system's functions. The requirements establish different levels of performance. The owner and system designer determine the expected level of performance.

5.3.1 Detection, Monitoring, and Control Network Transmission Path Performance

The fire alarms systems for WTC 1 and WTC 2 were very large systems with distributed panels located throughout each tower. Although each panel performed specific functions, the monitoring and control of the functions was performed as a single, holistic fire alarm system for the protected premises. The sharing of intelligence, monitoring, and control between the panels within the protected premises were accomplished through the system's network transmission paths. Tables within the NFAC define the performance requirements for the transmission paths. The Signaling Line Circuit table relates to the performance of the network transmission paths dealing with fire detection, life safety system monitoring and control functions.

These circuits support the fire detection, life safety system monitoring and control, occupant notification functions of the protected premises as a whole, and provide network interconnection to, monitor and control the distributed panels within each tower.

The performance criteria within the tables provide multiple levels of circuit performance, with each succeeding level proving increased survivability and endurance characteristics. All model building codes reference the NFAC, but the survivability and endurance performance of the network transmission paths as defined by the tables within the NFAC are not dictated by any model building code. It is the responsibility of the system designer to determine and specify signaling communication path performance requirements based upon the system architecture and performance goals. The Port Authority specified the most stringent circuit class and technical style available for all circuits including the Signaling Line Circuits (Class A, Style 7) and Notification Appliance Circuits (Class A, Style Z), which will be discussed in detail later in the report. The intent for using the most stringent class of circuits was to enhanced network survivability and endurance performance.

The performance criteria for the circuits are provided in Table 5–1.

Table 5–1. Performance of Signaling Line Circuits (SLC).

Class	B			B			A			B			B		
Style	0.5			1			2α			3			3.5		
	Alm	Trbl	ARC	Alm	Trbl	ARC	Alm	Trbl	ARC	Alm	Trbl	ARC	Alm	Trbl	ARC
Abnormal Condition	1	2	3	4	5	6	7	8	9	10	11	12	13	14	15
Single open	—	X	—	—	X	—	—	X	R	—	X	—	—	X	—
Single ground	—	X	—	—	X	R	—	X	R	—	X	R	—	X	—
Wire-to-wire short	—	—	—	—	—	—	—	—	M	—	X	—	—	X	—
Wire-to-wire short & open	—	—	—	—	—	—	—	—	M	—	X	—	—	X	—
Wire-to-wire short & ground	—	—	—	—	—	—	—	X	M	—	X	—	—	X	—
Open and ground	—	—	—	—	—	—	—	X	R	—	X	—	—	X	—
Loss of carrier (if used)/channel interface	—	—	—	—	—	—	—	—	—	—	—	—	—	X	—
Class	B			B			A			A			A		
Style	4			4.5			5α			6α			7α		
	Alm	Trbl	ARC	Alm	Trbl	ARC	Alm	Trbl	ARC	Alm	Trbl	ARC	Alm	Trbl	ARC
Abnormal Condition	16	17	18	19	20	21	22	23	24	25	26	27	28	29	30
Single open	—	X	—	—	X	R	—	X	R	—	X	R	—	X	R
Single ground	—	X	R	—	X	—	—	X	R	—	X	R	—	X	R
Wire-to-wire short	—	X	—	—	X	—	—	X	—	—	X	—	—	X	R
Wire-to-wire short & open	—	X	—	—	X	—	—	X	—	—	X	—	—	X	—
Wire-to-wire short & ground	—	X	—	—	X	—	—	X	—	—	X	—	—	X	—
Open and ground	—	X	—	—	X	—	—	X	—	—	X	R	—	X	R
Loss of carrier (if used)/ channel interface	—	X	—	—	X	—	—	X	—	—	X	—	—	X	—

Alm = Alarm.

Trbl = Trouble.

ARC = Alarm receipt capability during abnormal condition.

M = May be capable of alarm with wire-to-wire short.

R = Required capability.

X = Indication required at protected premises and as required by Chapter 8.

α= Style exceeds minimum requirements of Class A.

5.3.2 Detection, Monitoring, and Control Network Transmission Path Design, Installation, and Control

The fire alarm system's detection, monitoring, and control network transmission paths consisted of multiple limited area networks which consisted of 8 PSR slave panels connected to a MXL-VR master panel (see Figs. 5-21 and 5-22). The transmission path between the panels in this typical arrangement was referred to as the MNET by the manufacturer. The MXL-VR master panel monitored and controlled the PSR slave panels and their fire alarm initiating and indicating appliances (PANYNJ 1999a; PANYNJ 1999b; Drucker 2001; Drucker 2004).

In addition to the limited area networks, there was also a system network, which the manufacturer referred to as the XNET (see Figs. 5-23 and 5-24). The XNET provided an interface for the multiple MXL-VR master panels and the multiple NCC, which together operated as a single fire alarm system. The distribution of the MXL-VR master panels within each tower allowed each MXL-VR to act independently if isolated from the building XNET, or act in concert with the other MXL-VR panels when the network communication was sustained. Both towers had a NCC in their FCS and an additional Remote NCC, which was connected to their respective XNET, that was located in the OCC for redundancy (see Fig. 5-25). The remote NCC's provided complete monitoring and control of all WTC 1 and WTC 2 fire alarm system functions. In addition to the remote NCC in the OCC, the WTC 2 fire alarm system had a second remote NCC installed in WTC 1. The additional remote WTC 2 NCC was installed in WTC 1 to enhance the overall survivability of the WTC 2 fire alarm monitoring and control functions. The Port Authority determined that since the WTC 2 FCS was located above, and in relative close proximity to the OCC, an additional WTC 2 remote NCC was required in the WTC 1 FCS as an extra level of safety in case a catastrophic event affected the capabilities of both WTC 2 FCS and OCC due to their close proximity.

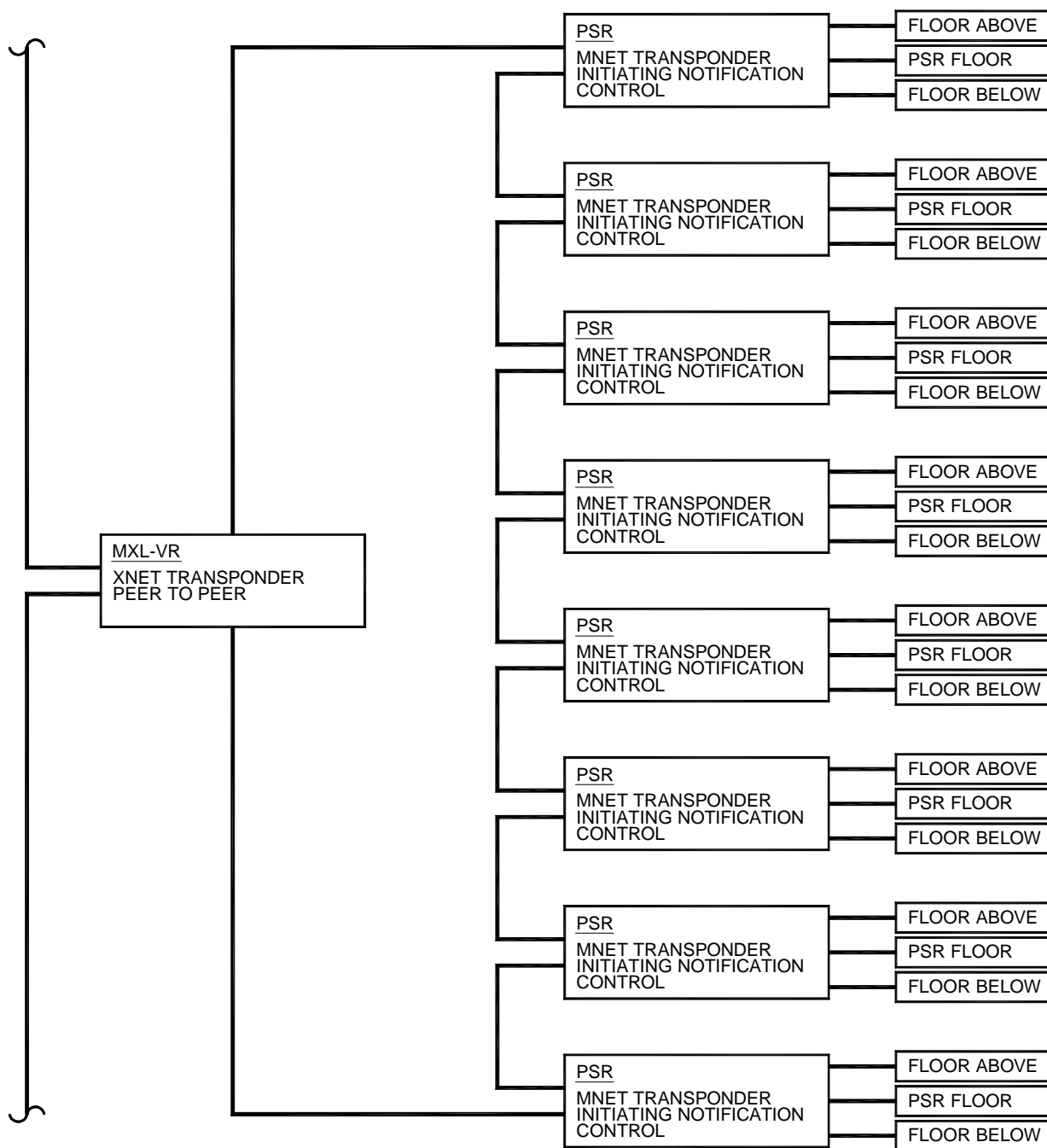

Source: Reproduced with permission of The Port Authority of New York and New Jersey.

Figure 5–21. Single-line schematic of MNET network configuration.

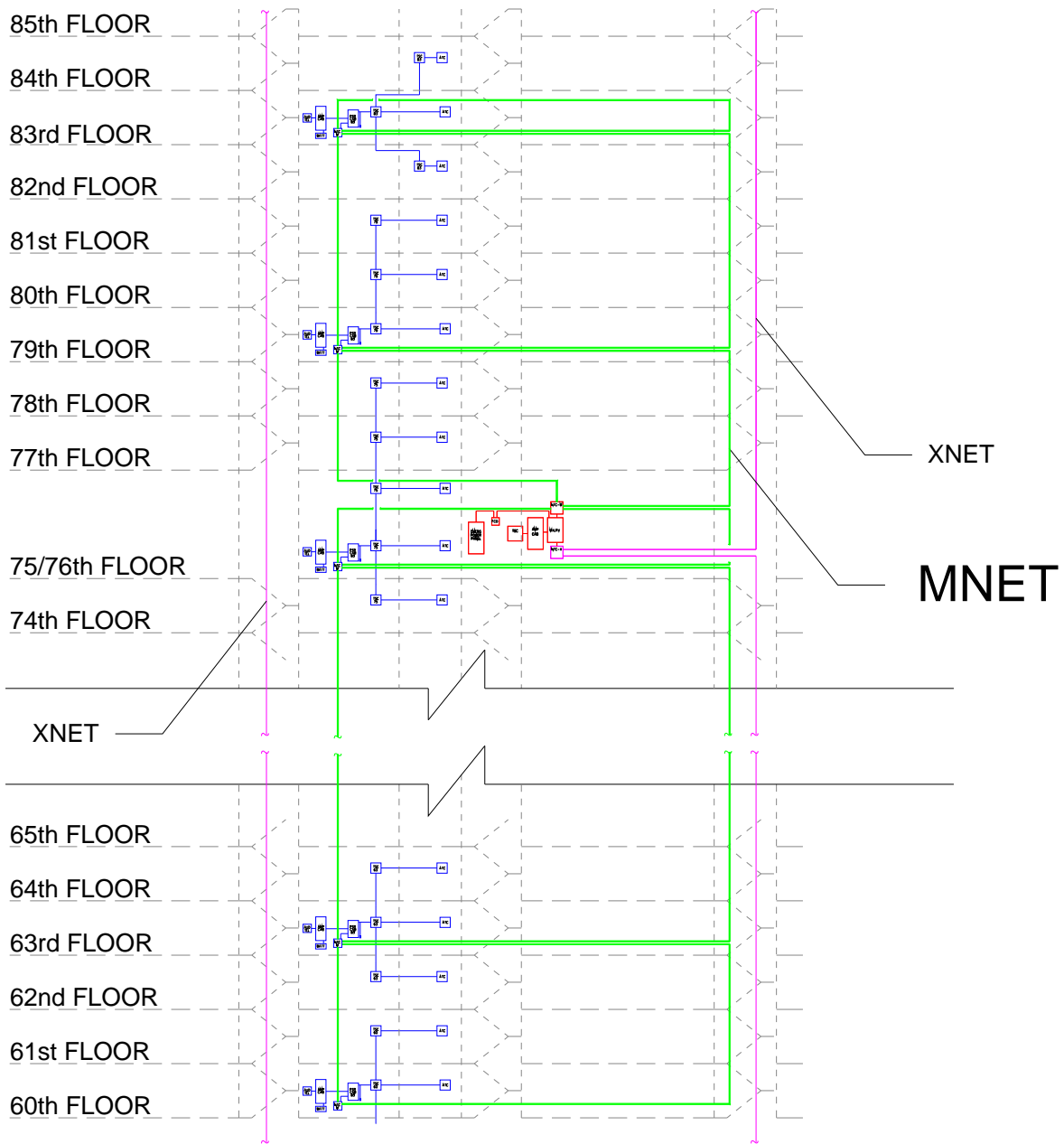

Source: Reproduced with permission of The Port Authority of New York and New Jersey.

Figure 5–22. Locations of typical MNET network equipment.

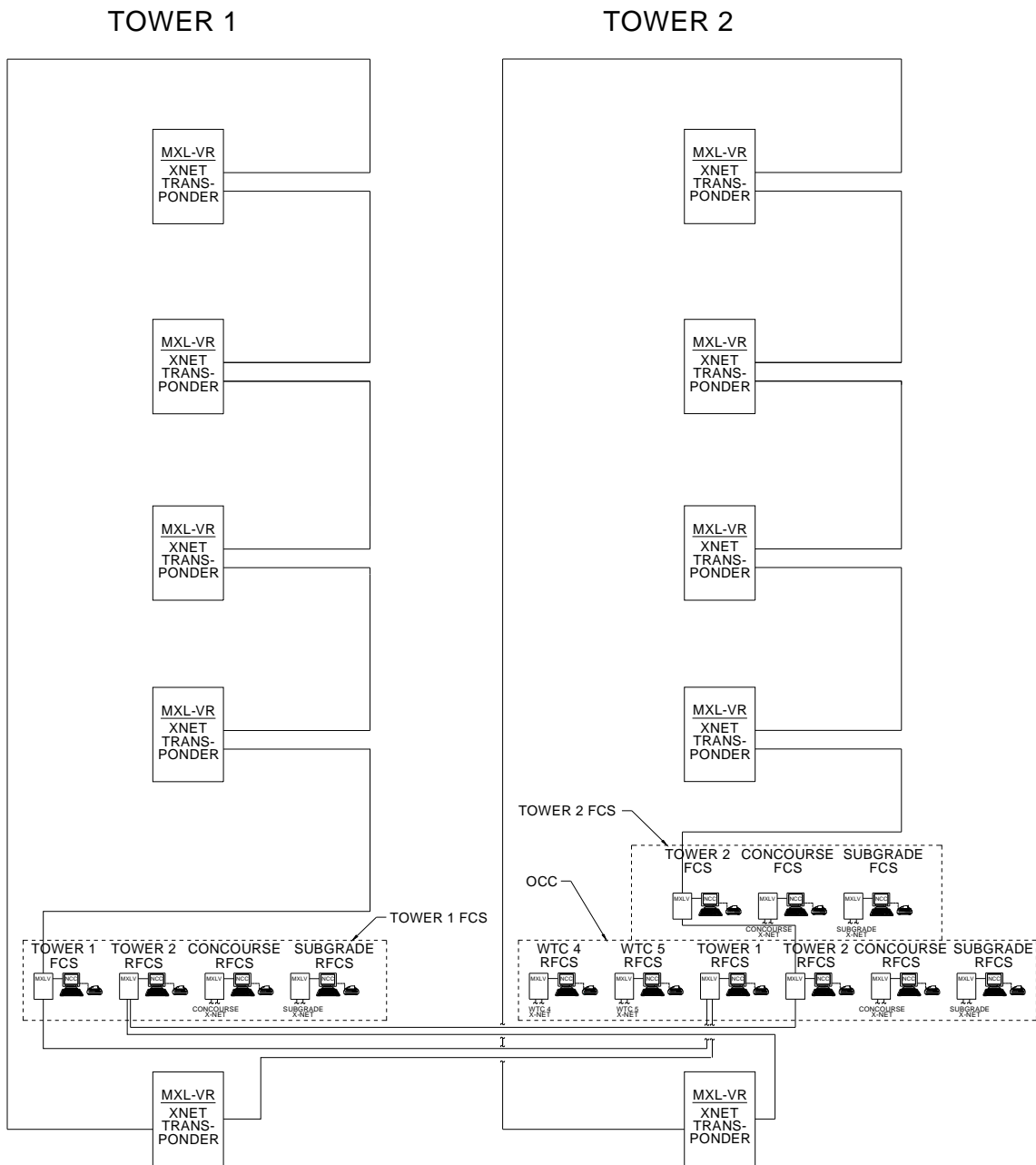

Source: Reproduced with permission of The Port Authority of New York and New Jersey.

Figure 5–23. Single-line schematic of XNET network configuration.

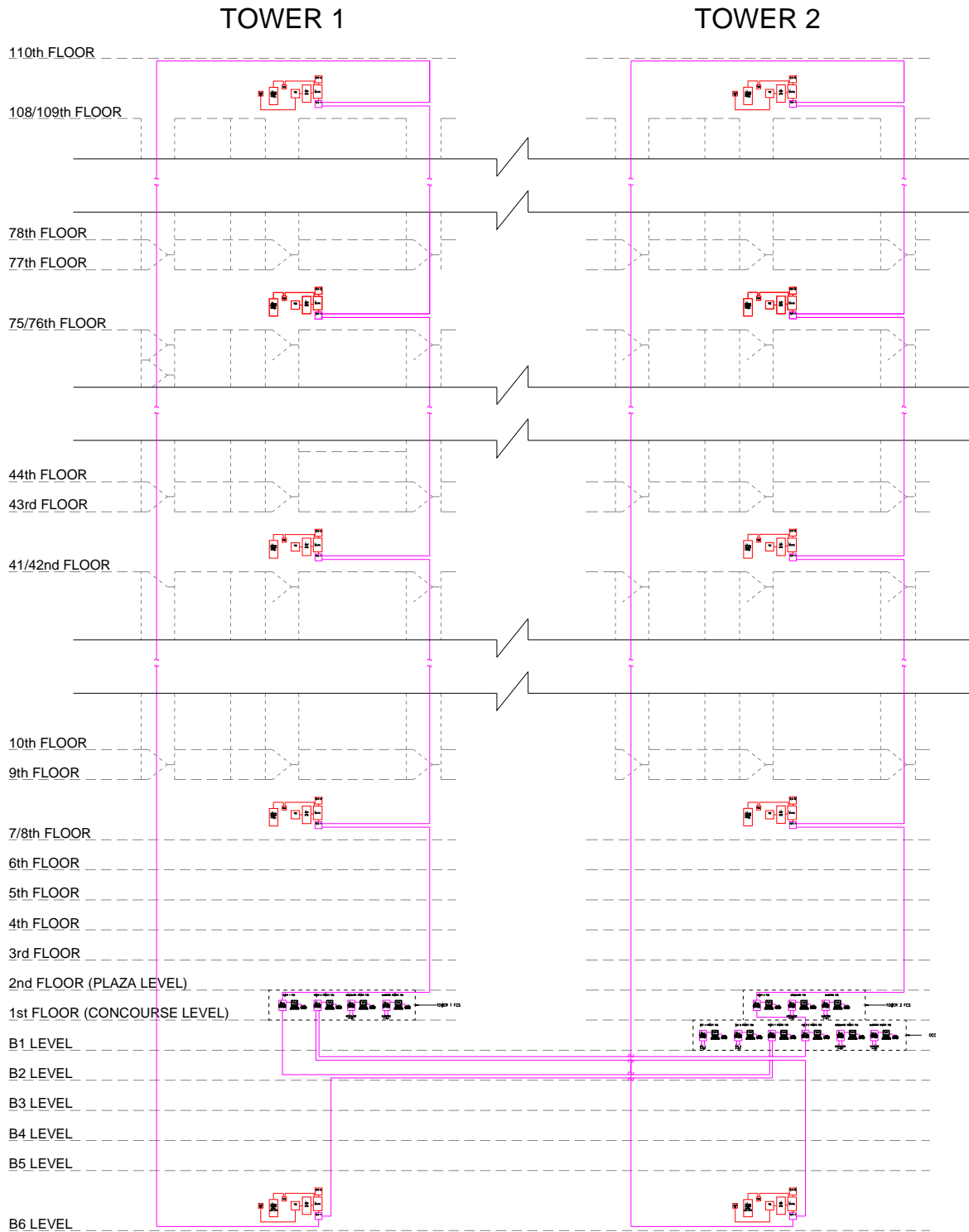

Source: Reproduced with permission of The Port Authority of New York and New Jersey.

Figure 5–24. Locations of XNET network equipment.



Source: PANYNJ 2000. Reproduced with permission of The Port Authority of New York and New Jersey.

Figure 5–25. Operation Control Center located on the B1 Level below WTC 2 with redundant fire alarm system controls.

The NCC for each tower contained central monitoring and master control through the MXL-V for the building's protected premises. The master MXL-V provided monitoring and control of the MXL-VR remote fire alarm panels through a Style 7 XNET network (see Fig. 5–22). The PSR slave panels (along with the MXL-VR panels) monitored and controlled fire alarm devices and communicated their status through a Style 7 MNET back to their Master MXL-VR panel. The XNET provided a communication path for the FCS and OCC to monitor the fire alarm and life safety system supervisory signals and control the interfaced life safety systems to the distributed MXL-VR panels and through the MXL-VR panels via the MNET (see Fig. 5–23) to the PSR panels.

The controlled life safety systems included the speaker circuits that provided the EVAC messages serving each floor and the stairways and also included controls for the switching of the warden and firefighter telephone calls. The XNET provided a pathway for the main MXL-V (located at the FCS) to control the distribution of the EVAC and telephone communication messages and calls, but did not transmit the EVAC messages or telephone calls. The EVAC and telephone transmission path circuits were separate and independent of the XNET and MNET transmission paths. The EVAC and telephone circuits provided the actual voice messages and calls when in use, and the XNET and MNET directed the distribution of the messages and calls. Figures 5–24 and 5–25 show the locations of XNET and MNET network equipment in WTC 1 and WTC 2.

The XNET and MNET design and installation provided enhanced network integrity and reliability through a loop wiring topology configuration that provided separate network communication path risers (primary and secondary) installed in three different locations (fire alarm closet and stairways “A” and “C”). Due to the excessive length of the network risers (each tower was approximately 1,350 ft high), the network was designed with #14 AWG Teflon cables (twisted pair 600 V, 200 °C). The intent of the Style 7 networks was to accommodate any type of single circuit fault, such as a cut wire, short between wires, or grounding of a wire on any section of the network. Fiber optic cable was originally presented for the network during meetings with The Fire Department of the City of New York (FDNY) Technology Management, but was rejected by FDNY electrical supervisors as not compliant with the NYC Code (CUMMISKEY 1993).

Fourteen pairs of cables were installed within the stairway “A” and “C” risers. The system only required five cables per riser, but the Port Authority intentionally installed additional cables for future use. The intent was to provide enough cables for the eventual replacement of the new fire alarm system. The additional cables would allow the installation of a redundant system during the transition from the existing system to a new system.

The system was designed to automatically compensate for faults on its XNET communication path by allowing MXL-VR systems to remain in communication with each other as a subsystem if a catastrophic failure were to separate a portion of the system from the head-end MXL-V panel at the FCS. The separated portion of the system would dynamically retain all communication and control logic associated with the remaining remote panels in communication with each other. Or, if a MXL-VR panel experienced catastrophic network failure, the panel would act as a fully independent control unit performing monitoring, notification, and control function assigned to the stand-alone control unit.

Design documents indicate that the Port Authority specified the most stringent performance criteria for the fire alarm network communication paths and installed the network cable and hardware in a manner that would enhance survivability and endurance from the risk of fire and physical damage. The XNET

and MNET riser consisted of Teflon sheathed cables rated at 200 °C and was installed in rigid conduit between the distributed panels. In addition to these stringent criteria for cable and hardware survivability, the separation of the risers provided physical protection of the network circuits from any localized fire or physical damage. The intent of the design criteria was to provide enhanced survivability through: robust circuit performance, cable and hardware with enhanced protection characteristics, and the physical separation of the risers. At the time of installation, this criteria exceeded all applicable code requirements for survivability and endurance characteristics for fire alarm systems within high-rise buildings.

5.3.3 Typical Detection, Monitoring, and Control Devices

The Siemens Pyrotronics devices used for detection, monitoring, and control represented state-of-the-art technology at the time of system design and installation. The devices included (PANYNJ 1999a):

- Addressable open area ionization smoke detectors (ILI-1)
- Addressable high-air velocity open area ionization smoke detectors (ILI-1A)
- Addressable duct ionization smoke detectors – high air velocity (ILI-1B)
- Addressable open area photoelectric smoke detectors (ILP-1)
- Addressable open area photoelectric smoke detectors with fixed heat detector (ILPT-1)
- Addressable open area rate compensated heat detectors (ID-60T-135)
- Addressable single input monitor modules (TRI-60)
- Addressable dual input monitor modules (TRI-60D)
- Addressable single input with relay control output modules (TRI-60R)
- Addressable single-action pull stations (MS-MI)

5.3.4 Typical Detection, Monitoring, and Control Device Design and Installation

As a minimum, the WTC mandated design guidelines (PANYNJ 1999a) required smoke detector protection in each elevator lobby, electrical closet, telephone closet, fire alarm closet, and at each HVAC air return (see Fig. 5–26). Also, manual stations were installed next to the three stairway access doors, and sprinkler water flow and tamper switches were monitored for alarm and trouble conditions, respectively. Additional fire alarm protection could be added by a tenant if their fire protection needs exceeded the life safety goals set by the Port Authority. If a tenant installed a fire alarm subsystem, an addressable monitor module (model TRI-60D) was required to monitor the subsystem for general alarm and system malfunction (trouble) conditions by the BBFAS.

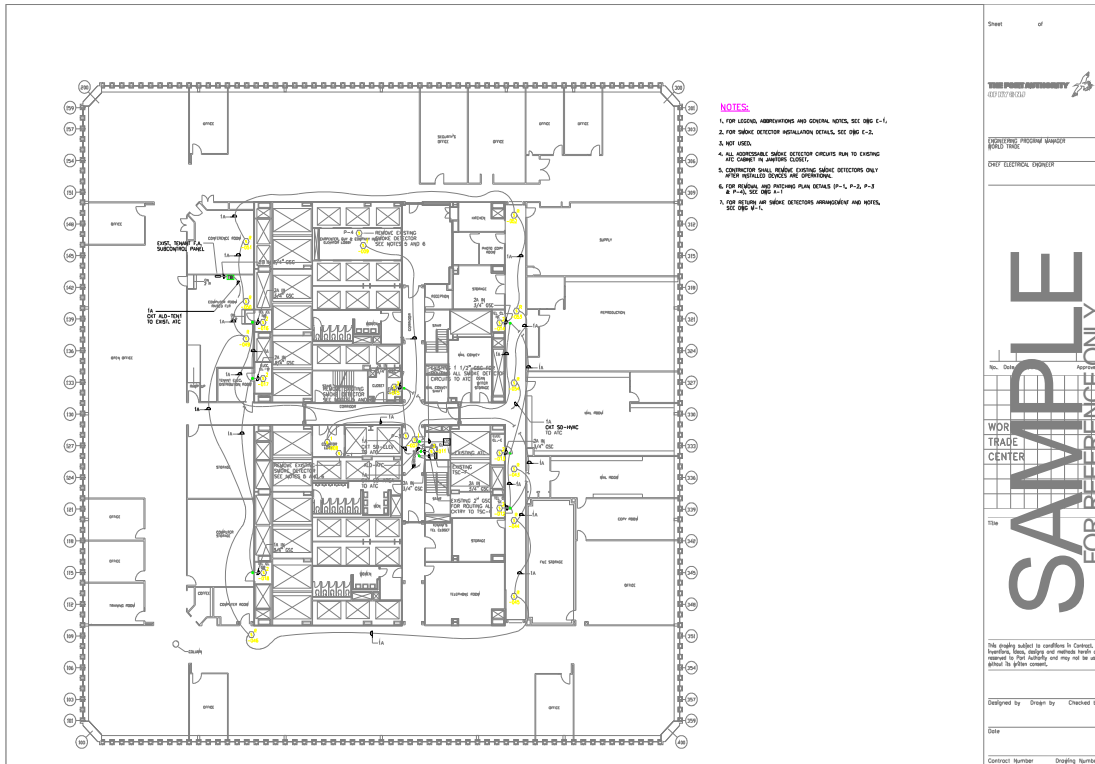

Source: PANYNJ. Reproduced with permission of The Port Authority of New York and New Jersey.

Figure 5–26. Typical detection, monitoring, and control device layout.

An Addressable Device Terminal Cabinet (ATC) was located in a typical floor’s Janitor’s Closet, and provided a Style 4 addressable device loop that was separated into five branch circuits. Each circuit used 14 AWG, shielded twisted pair 150 °C Teflon cable assemblies. Fifty-five device addresses were preallocated for each floor. The designations for the five branch circuits were (PANYNJ 1999a; Drucker 2001):

1. ELEV Branch – Elevator lobby smoke detectors, passenger and freight.
2. AREA Branch – Open area smoke detectors – phone, electric, and fire alarm closets.
3. HVAC Branch – Ventilation smoke detectors for plenums and ducts.
4. TEN1 Branch – Tenant 1 fire alarm subsystem interface monitoring by BBFAS.
5. TEN2 Branch – Tenant 2 fire alarm subsystem interface monitoring by BBFAS.

The separate elevator circuit was provided to reduce the probability of disabling the elevator recall functions during renovations or modifications of the open area circuits.

The smoke detection dedicated to the air handling units included detectors within the units located on the Mechanical Equipment Room (MER) on floors 7, 41, 75 and 108 and on each floor served by the units. The MER typically contained 12 air handling units that served 16 floors above the MER and 16 floors below the MER. A dedicated smoke detection zone in the MER was used to monitor an area smoke

detector installed within the air handling unit, past the unit's filter, and another duct detector installed in the supply duct exiting the unit. The activation of both of these detectors would activate a deluge fire sprinkler system dedicated to suppressing an air handling unit filter fire. In addition, area smoke detectors were installed in front of the air return units on each floor, which would shut down the air handling unit associated with the air return duct upon activation.

The Style 4 addressable device loop monitoring and controlling the fire alarm devices provided a custom message identifying each addressable device at the monitoring stations (FCS and OCC) whenever the device went into an alarm, was activated, or experienced a fault mode. The performance of the Style 4 circuit was compromised whenever the circuit experienced a single open (cut wire), wire-to-wire short, and loss of fire alarm communication to the device. Although the Style 4 performance serving each floor's detection, monitoring and control devices was not as robust as the network Style 7, the performance was consistent with the requirements in the building codes, fire alarm standards and codes, and product safety standards.

5.3.5 Notification Appliance Circuit Network Transmission Path Performance

The Notification Appliance Circuit performance table relates to the performance of the occupant notification network transmission paths, as opposed to the Signaling Line Device Circuit table which relates to the performance of the network transmission paths dealing with fire detection, life safety system monitoring, and control functions. The Notification Appliance Circuits used were Class A, Style Z, which requires stringent performance for the circuits as shown in Table 5–2 (NFPA 2002).

Table 5–2. Notification Appliance Circuits (NAC).

Class	B		B		B		A	
Style	W		X		Y		Z	
	Trouble indication at protected premises	Alarm capability during abnormal conditions	Trouble indication at protected premises	Alarm capability during abnormal conditions	Trouble indication at protected premises	Alarm capability during abnormal conditions	Trouble indication at protected premises	Alarm capability during abnormal conditions
Abnormal Condition	1	2	3	4	5	6	7	8
Single open	X	—	X	R	X	—	X	R
Single ground	X	—	X	—	X	R	X	R
Wire-to-wire short	X	—	X	—	X	—	X	—
X = Indication required at control equipment. R = Required capability.								

5.3.6 Notification Appliance Circuit Network Transmission Path Design, Installation, and Control

The EVAC speakers and strobes were manually controllable and operable at the FCS or the OCC, depending on which station had operational rights to the system. The control equipment consisted of a microphone and switches for turning on individual audio and visual notification zones, or the all-call capability to broadcast on all speaker zones. The speaker and strobe zones were segregated by floor and also grouped by elevator zones. The elevator speaker grouping provided a switch that would activate the floors served by the low zone of elevators serving floors 9 through 40; a separate switch would activate the floors served by the mid zone of elevators serving floors 44 through 74; and a third elevator group switch would activate the floors served by the high zone of elevators serving floors 78 through 107. In addition, the stairways were on a separate speaker zone, controlled by a switch (PANYNJ 1999a; Drucker 2001; Drucker 2004).

The switches also allowed the voice message to include an alarm tone associated with evacuation or an alert tone. Both tones would be a preamble to an advisory voice message when the microphone was activated. In addition, there was a switch to use a floor warden or firefighter telephone as a remote microphone to broadcast a voice message over selected or all zones. The status of all of these functions was visually displayed via indicator lamps. The visual display, and a distinct audible tone, also provided an indication if a specific zone or function was experiencing a technical fault that would affect its performance.

The fire alarm system's audio notification network transmission paths consisted of two separate circuits that provided two channels for emergency voice and alarm communication (see Figs. 5-27 and 5-28). The separate channels allowed the operator to broadcast separate messages or tones simultaneously. The intent was to be able to provide instructions for evacuation to the fire floor while simultaneously alerting the occupants of adjacent floors to stand by for further instructions.

The fire alarm system's emergency voice communication messages were transmitted on a network path to all the MXL-VR and PSR panels containing amplifiers and their associate speaker circuits (see Fig. 5-27). The intent of the Style Z notification appliance circuit network design and installation was to provide enhanced network integrity and reliability through a loop wiring topology configuration that provided separate network communication path risers (primary and secondary) installed in two different locations (fire alarm closet and stairway "C"). The network was designed with #14 AWG Teflon cables (twisted pair 600 V, 200 °C). The performance characteristics of the Style Z network allowed continued service if the circuit experienced a single circuit fault, such as a cut wire, or grounding of a wire on any section of the network. But, the network would not provide continued service if it were to experience a wire-to-wire short.

As with the other communication network paths, the Port Authority specified stringent performance criteria for the notification appliance circuit network communication paths (Class A, Style Z) and installed the network cable and hardware in a manner that would enhance survivability and endurance from the risk of fire and physical damage. The notification appliance riser consisted of two Teflon sheathed cables rated at 200 °C, each containing a shielded twisted pair of wires. The cables were installed in rigid conduit between the distributed amplifier panels (see Fig. 5-28). In addition to these stringent criteria for cable and hardware survivability, the separation of the risers provided physical protection of the network circuits from any localized fire or physical damage. The intent of the design

criteria was to provide enhanced survivability through: robust circuit performance, cable and hardware with enhanced protection characteristics, and the physical separation of the risers. At the time of installation, these criteria exceeded all applicable code required survivability and endurance characteristics for fire alarm systems within high-rise buildings.

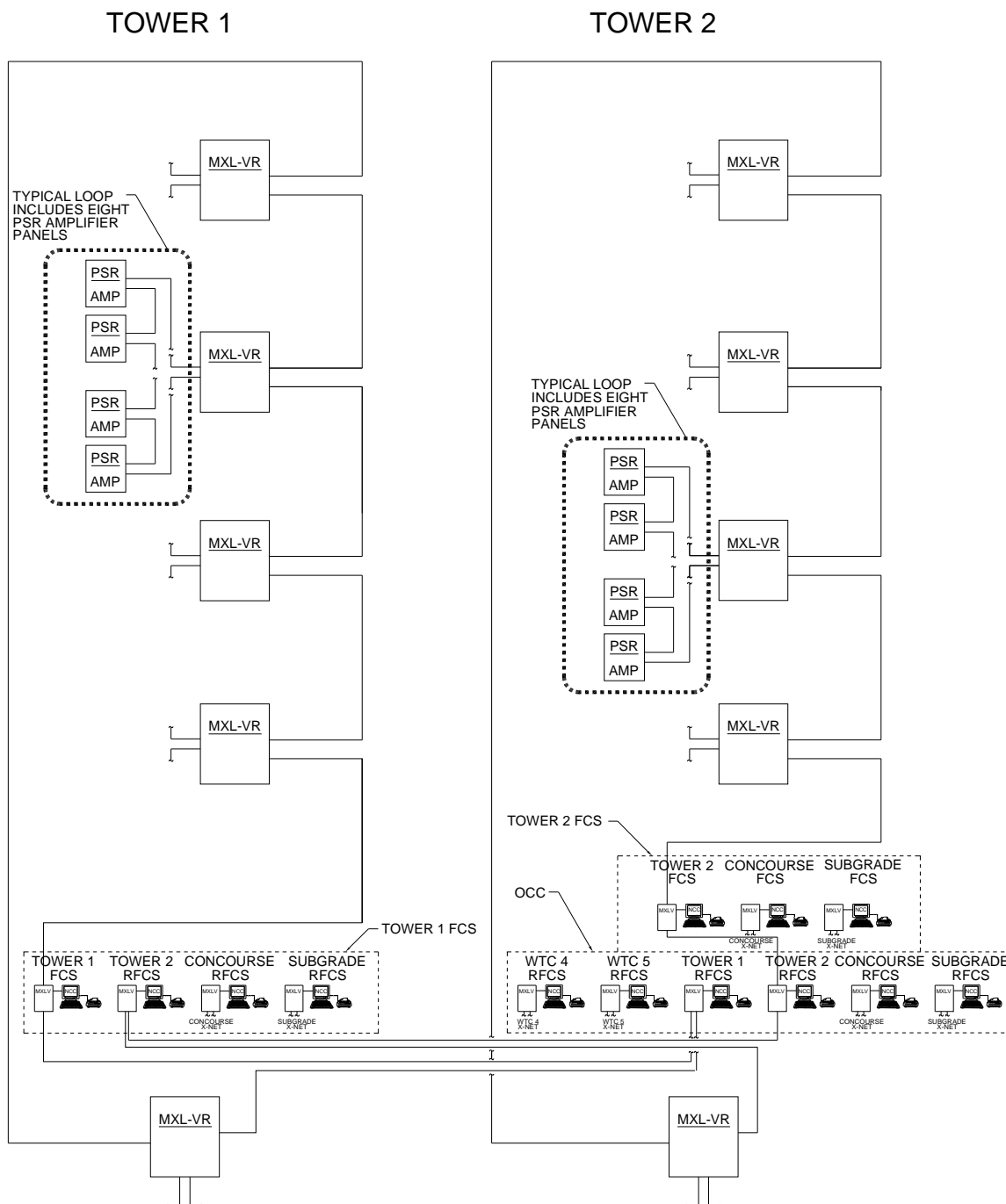

Source: Reproduced with permission of The Port Authority of New York and New Jersey.

Figure 5–27. Single-line schematic of notification appliance network.

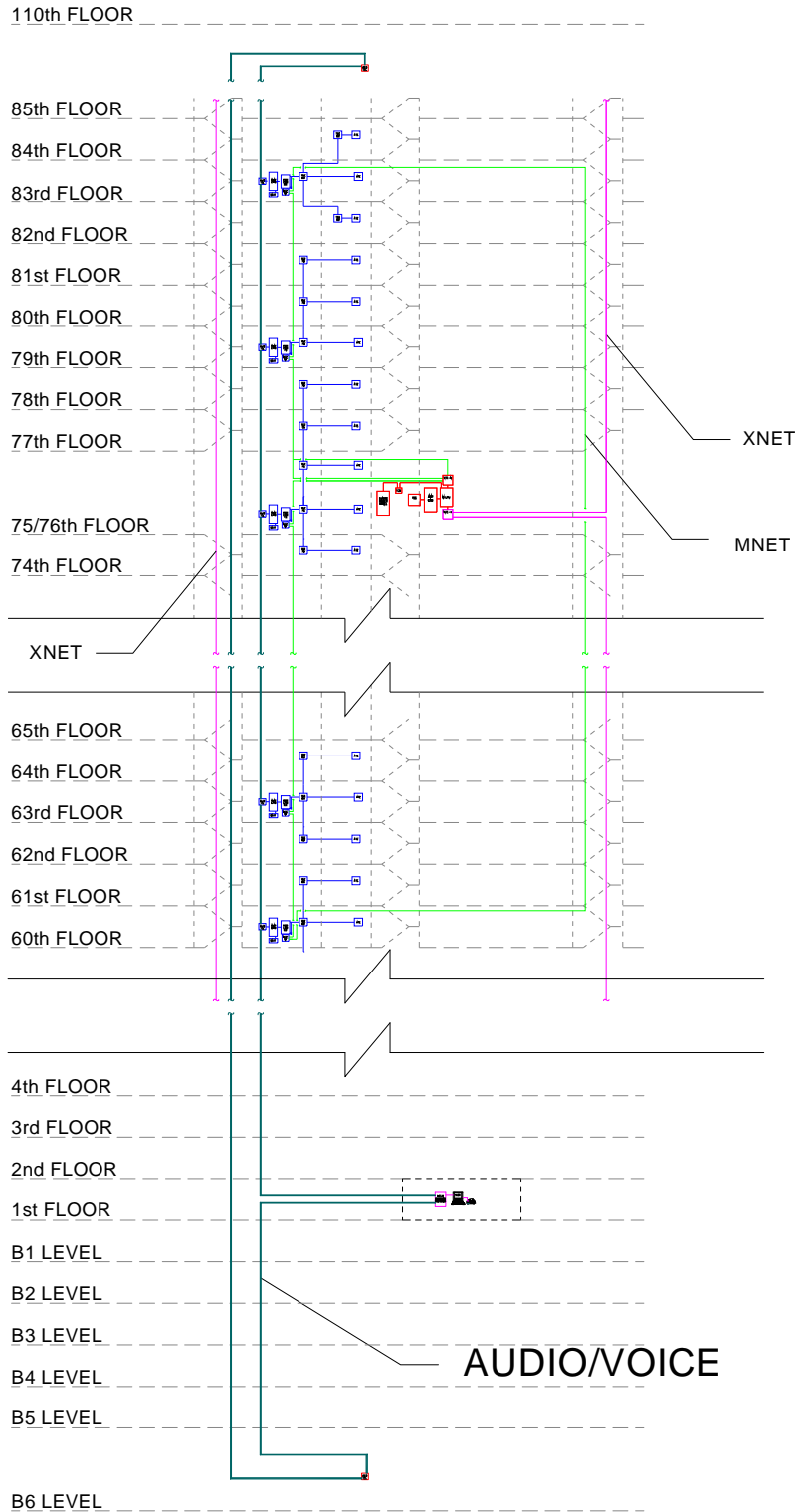

Source: Reproduced with permission of The Port Authority of New York and New Jersey.

Figure 5–28. Locations of audible notification appliance network equipment.

5.3.7 Typical Speaker Notification Appliance Devices

The Siemens Pyrotronics devices used for audio notification included (PANYNJ 1999a; PANYNJ 1999b; Drucker 2001):

- Ceiling mounted round speakers, 70 V (SPK-9070)
- Wall mounted square speakers, 70 V (SPK-7070)
- Wall mounted speakers, 25/70 V (SPK-1070)
- Wall mounted speakers, 70 V, with 24 V 15/75 cd strobe (SS70-15/75)

The Port Authority performed an in-depth analysis on speaker intelligibility and audibility for the WTC (Drucker 2001). The intent of the analysis was to develop a speaker location guideline that would ensure an acceptable level of intelligibility (message clarity) and audibility (loud enough to be heard.).

The audible alarm requirements were based upon the American with Disabilities Act and NFPA requirement for the alarm signal to maintain a 15 dBA sound pressure level above the average ambient sound level measured 5 ft above the floor in the occupied area (NFPA 2002). To establish the ambient sound level, the Port Authority conducted an extensive sound level survey to establish a baseline for design. Testing results indicated that the average ambient sound level in office areas and in occupied corridor areas was 55 dBA and 60 dBA, respectively. Based upon computations for sound loss and reverberation (echo effect), a standard was established that the distance between speakers would not exceed 40 ft.

A TSC was located in a typical floor's Sprinkler Closet or Fire Alarm Closet, and provided four Style Z speaker circuits. The speaker circuits were designated SPK –A, B, C, D, and a single stairway circuit designated SPK-E was provided for the three stairways, typically every four to five floors. Each circuit used as a minimum 14 AWG, shielded twisted pair 150 °C Teflon cable assemblies. Each circuit was rated for a maximum load of 25 W at 70.7 VRMS, with a maximum combined load of 25 W for all four circuits. The three stairways each had a dedicated speaker circuit with a speaker installed every four to five floors.

Enhanced survivability was incorporated through counter-rotating interleaved speaker circuits (see Fig. 5–29). This approach required alternating speakers to be serviced by separate circuits. The intent was to insure that a loss of a single circuit would not cause the complete loss of audible signals within the area. This concept exceeded building code requirements.

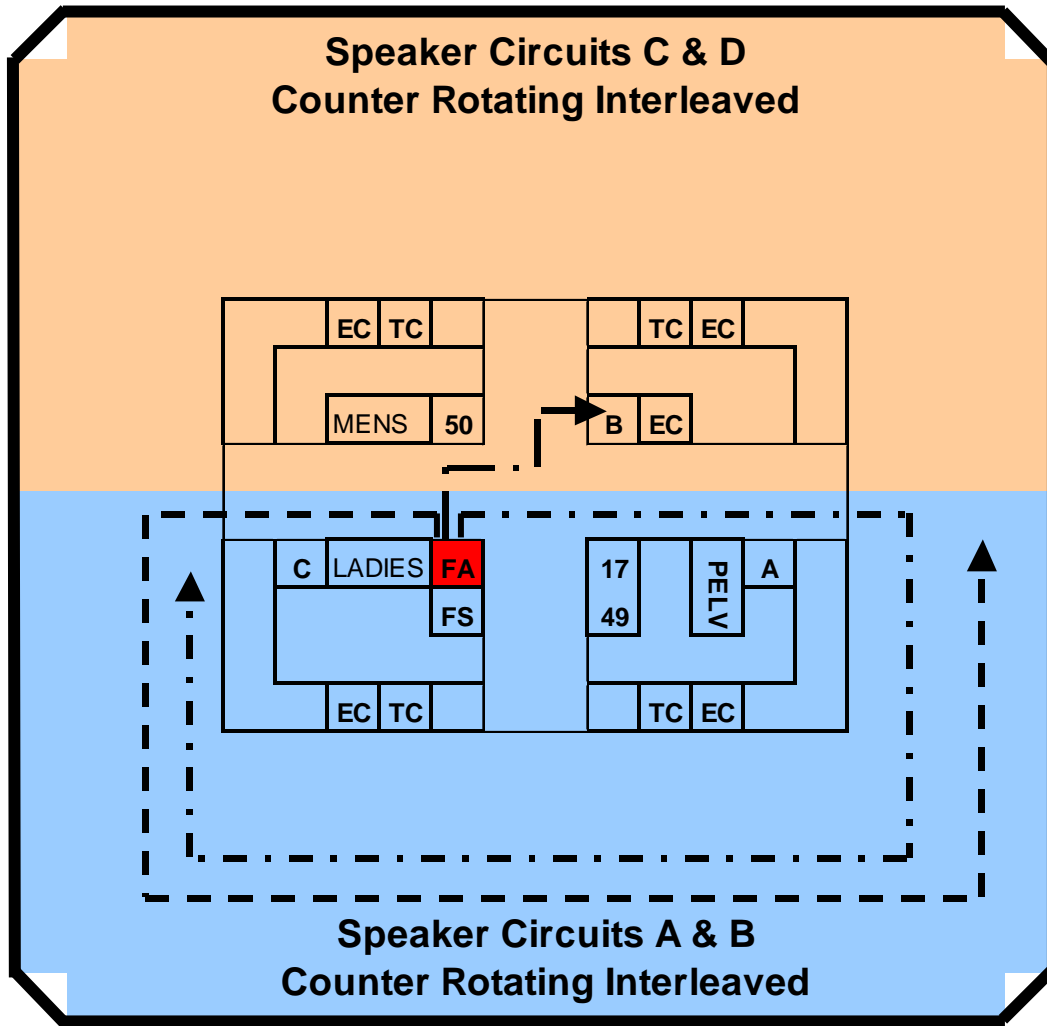

Class B- 70.7 V - 150 / 200C Teflon FPLP Free Air
 4 Circuits Provided Per Floor + Additional Stairway Only
 Circuit typically every 4-5 Floors. Coordinated with Reentry
 Points.

Source: Drucker 2001.

Figure 5–29. Speaker circuit configurations.

5.3.8 Typical Strobe Notification Appliance Devices

The Siemens Pyrotronics devices used for audio notification included:

- Wall mounted strobes, 24 V 15/75 cd (S15/75-SGL)
- Wall mounted combination speaker, 70 V, with 24 V 15/75 cd strobe (SS70-15/75)

5.3.9 Typical Strobe Circuits Equipment and Installation

The visual notification requirements were based upon the ADAAG, NFPA, and maintaining 0.0375 ft-candles illumination within the protected area (NFPA 2002).

A TSC was located in a typical floor's Sprinkler Closet or Fire Alarm Closet and provided six Class B speaker circuits for each floor (see Fig. 5–30). Each circuit used as a minimum 14 AWG, shielded twisted pair 150 °C Teflon cable assemblies. Each circuit was rated for a maximum load of 1.5 Amps at 24 VDC, with a maximum combined load of 7.2 Amps for all six circuits. The circuits were installed based upon an assigned quadrant.

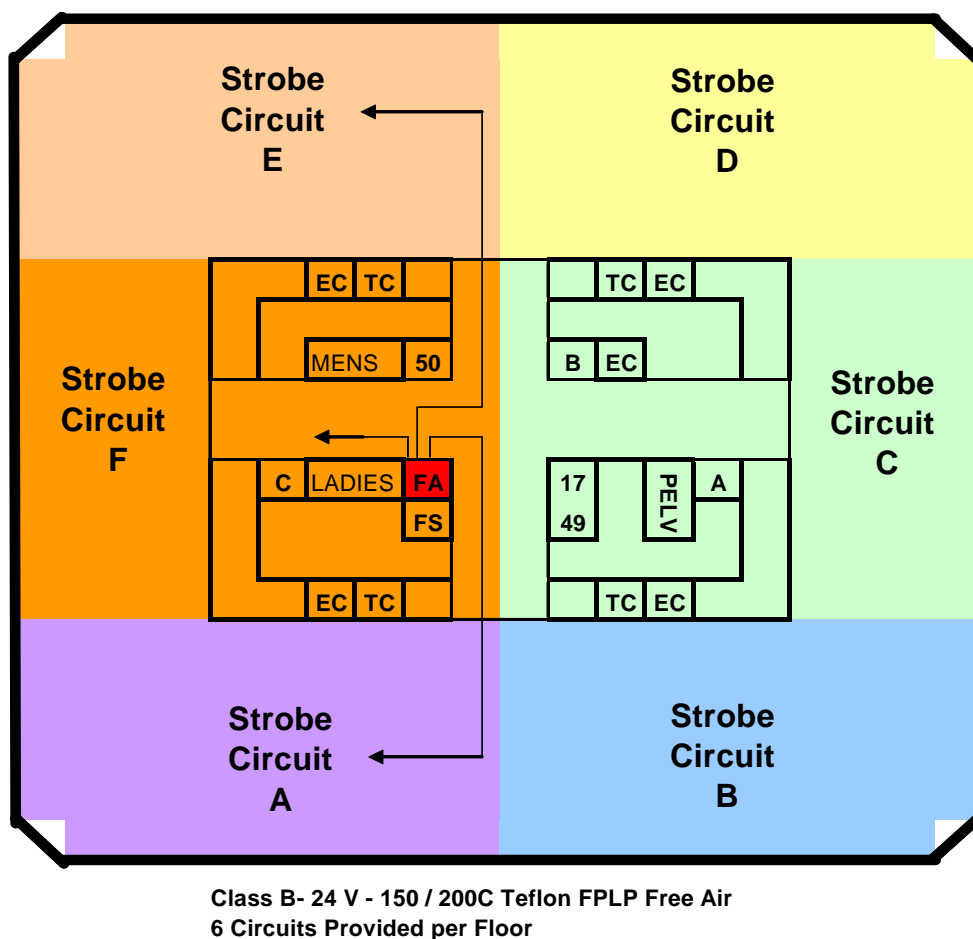

Source: Drucker 2001.

Figure 5–30. Strobe circuit configurations.

5.3.10 Floor Warden and Firefighter Telephone Network Transmission Paths

The WTC 1 and WTC 2 fire alarm systems were provided with two-way telephone communication between the FCS and the floor warden telephone stations, along with the standpipe fire line telephone stations. The two-way telephone network transmission path originated in the FCS and served each floor within the towers (PANYNJ 1999a; PANYNJ 1999b; Drucker 2004). The NFAC does not directly define

the two-way telephone circuit performance. The NFAC telephone performance requirements define the number of units that can simultaneously operate and the control parameters for their use. The ability of the telephone network transmission circuit to indicate an abnormal condition was not dictated by the NFAC. Neither the building codes nor the present ULI testing standards defines the performance of the telephone circuit. This abnormal condition monitoring of a single wire-to-wire fault, single open circuit, or single ground fault for telephone/intercom signaling circuits is scheduled to be a Underwriter Laboratory Inc. testing standard requirement effective October 1, 2005. The two-way telephone communication circuits serving WTC 1 and WTC 2 did have this circuit monitoring capability, which provided a visible and audible indication whenever the circuit experienced an open, short, or ground. This circuit monitoring capability exceeded codes and testing standards.

5.3.11 Floor Warden and Firefighter Telephone Network Transmission Path Design, Installation, and Control

The fire alarm system's floor warden and firefighter telephone transmissions were carried on a single, dedicated telephone network communication path to all the MXL-VR and PSR panels that served the telephones within each tower (see Figs. 5-31 and 5-32). The telephone network consisted of a single pair of #14 AWG Teflon cables (twisted pair 600 V, 200 °C). The single pair of wires did not have the enhanced survivability characteristics associated with the Class A, Style 7 Signaling Line Circuit or Class A, Style Z Notification Appliance Circuit. The Class B, Style Y circuit performance allowed a single open (cut wire) or wire-to-wire short to disrupt service between the head-end MXL-V panel and beyond where the wire fault occurred.

Although the circuit performance for the telephones was not as robust as the Signaling Line Circuits and Notification Appliance Circuit Networks, the telephone circuit's performance contained survivability capabilities that exceeded performance requirements for fire alarm systems. The applicable building codes, fire alarm codes, and testing standards did not require the telephone circuits to have the performance monitoring and survivability characteristics, inherent to the telephone circuits. The manufacturer provided the enhanced performance characteristics and the Port Authority selected to utilize the system for their floor warden and firefighter telephone communication needs.

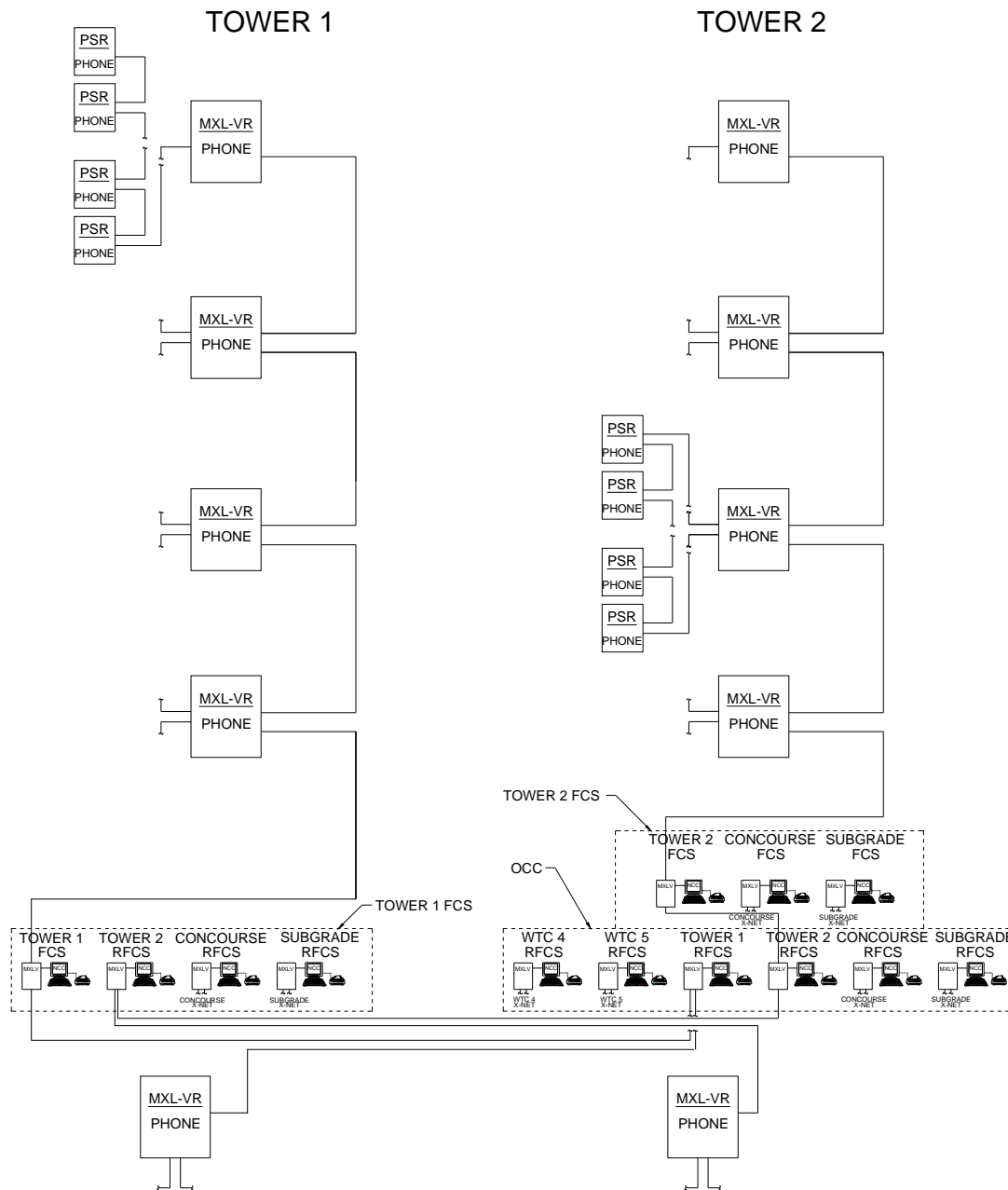

Figure 5-31. Single-line schematic of floor warden and firefighter telephones.

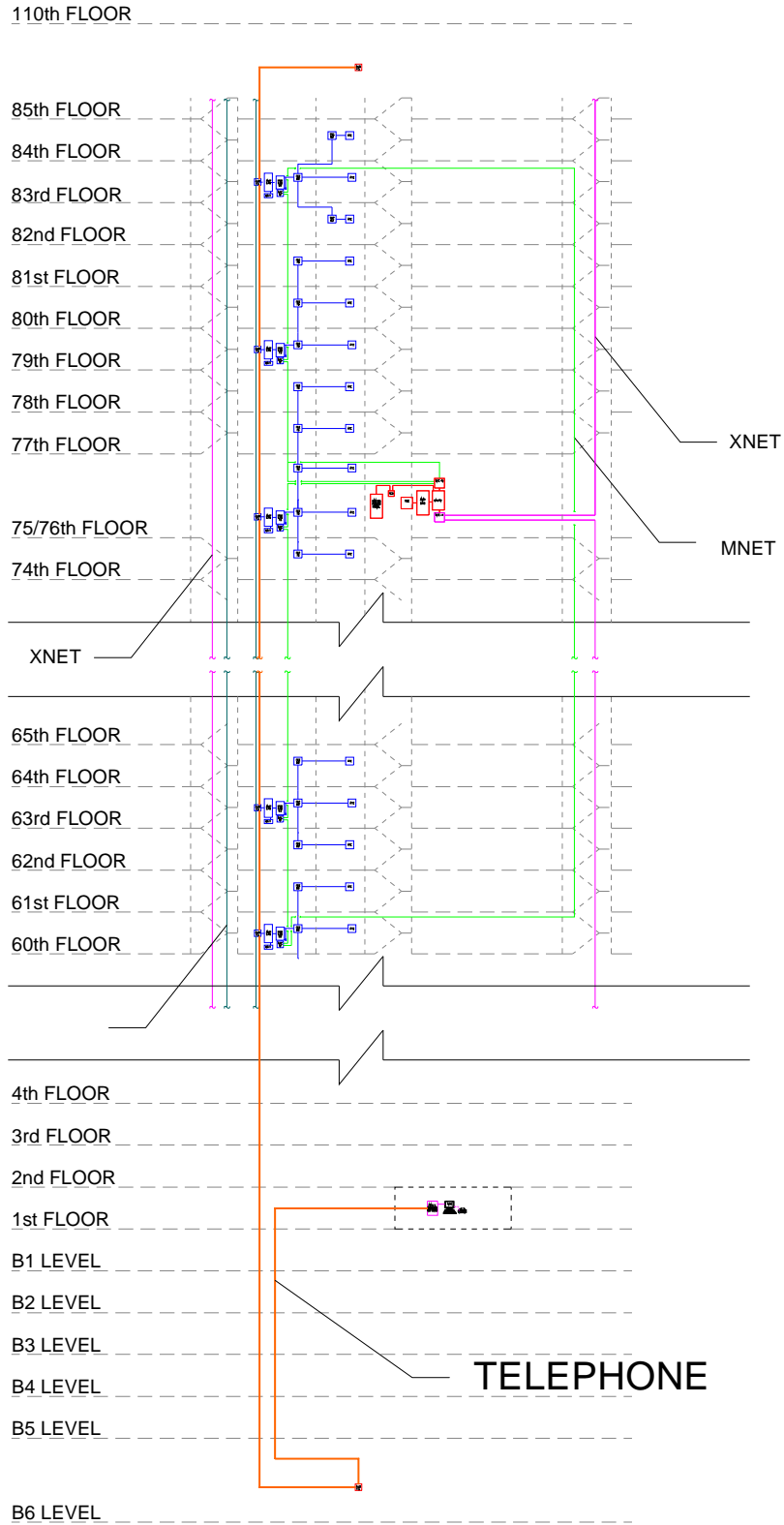

Figure 5–32. Locations floor warden and firefighter telephone network equipment.

5.3.12 Typical Floor Warden and Firefighter Telephone Devices

The Siemens Pyrotronics devices used for audio notification included:

- Flush wall mounted floor warden telephone station (FB-300)
- Surface wall mounted floor warden telephone station (FB-301S)
- Remote firefighters telephone station with armored cable (FT-301CL)
- Surface box for firefighter standpipe or maintenance jack (PUR17)
- Firefighters telephone jack (FJ-303)
- Portable firefighters telephone (PT-304)

5.3.13 Floor Warden and Firefighter Telephone Station System Design and Installation

The floor warden and firefighter telephone system consisted of the main telephone handset and controls located at the FCS and OCC, remote firefighter telephone stations located within the stairways, and floor wardens telephone stations located within the central cross-corridor on each floor. In addition to these stations, a maintenance telephone station was provided at each of the MXL-VR panel locations for maintenance personnel use (PANYNJ 1999a; PANYNJ 1999b; Drucker 2001; Drucker 2004).

The firefighter telephone station consisted of a connection point (jack) for a telephone handset. The intent was to provide responding firefighters with a handset before they were dispatched to the fire emergency. A call-in signal would be transmitted to the FCS whenever a handset was connected to the jack located at the station. The signal would indicate which floor initiated the call. Permanent handsets were not installed within the stairways. The jack connections were installed within metal boxes with locks that could only be opened by a standard FDNY key.

The floor warden station consisted of a handset that would automatically initiate a call-in signal at the FCS when the handset was removed from its cradle. The signal would indicate which floor had initiated the call.

The maintenance telephone station consisted of a connection jack for a telephone handset. The MXL-VR maintenance telephone station was connected to the same zone as the firefighter station. Separate zones were not provided since the maintenance station would not be in use during a fire emergency. As with the firefighter station, a call-in signal would be transmitted to the FCS whenever a handset was connected to the jack at the station. The signal would indicate which floor initiated the call.

The head-end FCS telephone controls, with redundant controls at the OCC, consisted of a handset and operator controls. The controls consisted of a push button switch and dual color light to indicate the status of the telephone station. When a call was placed on a telephone zone, the light would flash, and an audible tone would sound to indicate the telephone communication request. Once the operator selected the call, the telephone circuit was patched into a “party line” mode where up to five telephone stations could be on the line without loss of audio quality.

5.4 MAINTENANCE PERFORMANCE STANDARD

Fire alarm system availability and performance is dependant on four basic factors:

1. Equipment.
2. Design
3. Installation
4. Maintenance

Since the maintenance of the system affects of any system's life-cycle, its impact on the overall system availability and performance is a major consideration during the selection of equipment, design of the system, and the installation of the equipment and devices. The documentation found suggests that maintenance of the system was considered during system development and was carried out regularly after the system was installed (PANYNJ 1984; PANYNJ 1986).

A team was contracted from Siemens Pyrotronics to perform fire alarm maintenance and repair functions for the WTC. The maintenance procedures included scheduled testing of the fire alarm system's detection, controls, communication, and notification capabilities. The testing was scheduled by area and included all the fire alarm functions within the area. Before testing was performed, notices were posted informing the occupants of the pending testing. Specific testing procedures were performed by specific team members during the system test. The results of the testing were recorded for reference.

5.5 SYSTEM DESIGN AND INSTALLATION CRITERIA FOR WTC 7

WTC 7 was built in 1985. It was located across Vesey Street from the main WTC complex. It was a steel building which had forty-four floors. WTC 7 collapsed on September 11, 2001, roughly seven hours after WTC 1 and WTC 2 collapsed.

The fire alarm system for WTC 7 appears to have been the original system installed when the building was built (Syska 1984). Modifications were performed as needed to accommodate renovations and tenant fit outs. Project development documentation found and analyzed has been limited to specifications, riser diagrams, and a limited number of tenant fit out drawings that included fire alarm work. The design criteria were based on the requirements set by the Basic Design Criteria revised November 5, 1984, proposed by Syska & Hennessy, which reference the applicable local building codes at the time of construction. The only performance criteria in the design criteria that exceeds the minimum requirement was the statement requiring "All monitoring, communication and control for the fire alarm system shall be on a separate multiplex channel with its own processor" (S&K 1984). Based on the information reviewed, the overall design and installation was consistent with the applicable code requirements. Inspection, testing, and maintenance of the fire alarm system for WTC 7 was provided on a regular basis.

5.5.1 System Arrangement

The baseline for defining the fire alarm system's performance is derived from the specifications, which referred to the applicable local building codes. The basic system was required to contain the following components to monitor and annunciate the status of its devices and initiate an appropriate response (Syska 1984):

1. FCS located in the lobby of the building on the entrance floor.
2. Manual Fire Alarm Stations provided in each story along the path of escape with additional stations installed so that the maximum travel distance between stations would not exceed 200 ft.
3. Speakers located on all floors, and stairways that could be operated in the FCS. The elevator intercommunication system was provided separately.
4. Visual Alarm Devices (strobes) were provided in spaces used by people having physical disabilities during more recent renovations. When the strobes were first introduced and what areas contain strobes is unknown.
5. Floor Warden Stations on each floor that provided two-way communication with the FCS.
6. Standpipe Fire Line Telephone System with communication stations provided at FCS, each floor near the standpipe riser, gravity tank rooms, and fire pump rooms.
7. Fire Sprinkler water flow alarm and malfunction monitoring.
8. Tenant fire alarm panels monitoring for alarm and system fault conditions.
9. Fan shutdown and restart system for smoke control.
10. Elevator recall upon its smoke detector activation.
11. Fire stair door releases.
12. Smoke and heat detection

5.5.2 Design Approach

Documentation found consisted of modified riser as-built diagrams, and floor plans with fire alarm device locations. Comprehensive as-built drawings for the system were not located.

The modified riser diagrams were conceptual in nature, and provided the installation contractor with the number of devices installed on each floor, type of fire alarm equipment on each floor, and the number and type of wire interconnecting the devices and equipment. The modified riser diagram had areas crossed off, which was an indication that the area had undergone renovation. Additional renovation drawings provided a section of the riser with its modifications. The final drawings consisted of the partially

modified riser diagrams with areas crossed out, separate drawings containing a revised section of the riser, and floor plans with the locations of the devices on the designated floor.

It appears that the contractor was responsible for determining the final circuit configurations for the devices and equipment based upon the drawings found.

5.5.3 Typical Fire Alarm Equipment and Device Locations

The documentation found provided limited information on the specific location of the fire alarm control equipment, initiating devices, and communication equipment (Syska 1984). The base fire alarm system was a Firecom 8500 series fire alarm and voice communication system.

The Third Floor Lobby was found to be designated as the FCS. The FCS contained the Firecom 8500 Fire Command Center with printer and video monitor. On a typical floor, a system transponder/terminal cabinet was provided for monitoring the manual pull stations located at each stair entrance and smoke detectors in the electrical/telephone closets and elevator lobbies. Sprinkler water flow switch and valve supervisory switch in each stairwell were also monitored by fire alarm transponder/terminal cabinets. In addition, duct smoke detectors were installed in HVAC systems over 2,000 cfm and located at the main supply duct and the return air duct and were monitored by the transponder/terminal cabinets. The fire warden stations were installed separately on the north wall outside the elevator lobby.

5.5.4 Typical Fire Alarm Cabinet Connections

A mechanical room was located in the core area of each floor (Syska 1984). The south wall of the mechanical room was the designated location for fire alarm transponder/terminal cabinets, which supported and distributed the system's monitoring, control, and communication circuits. The initiation device circuits, speaker circuits, and the notification appliance circuits serving that floor were terminated at the transponder/terminal cabinet at this location. Bulk amplification for the entire building was located on the fifth floor and distributed through the transponder/terminal cabinets located on each floor. Documentation was not located that provided a standard for the equipment or device connections.

5.5.5 Typical Fire Alarm Installation Detail

Drawings were not located that provided guidance on the installation of the devices to meet tolerances required by code and the manufacture.

The riser diagrams indicate that the smoke detector, manual pull station, speaker and strobe circuits were configured to be a Class B type (Syska 1984). The use of a Class B circuit was consistent with the minimum requirements for performance, but did not have the higher level of survivability capabilities associated with a Class A circuit.

5.5.6 Fire Alarm Device Design Detail

Drawings were not located that provided design detail showing the number of wires required to run between each device and between the device and equipment.

5.5.7 Fire Alarm Power Calculations

Fire alarm power calculations were not located that would document the capability of the fire alarm equipment to power the number and type of devices connected to the equipment.

5.5.8 Quality and Performance Assurance Forms

Quality control documentation was not found for the installation.

5.5.9 Installation Acceptance Testing and Commissioning Procedures

Documentation was not found that documented the testing and commissioning procedures.

5.5.10 Inspection, Testing, and Maintenance

Inspection, testing and maintenance are mandated by the applicable building codes after a fire alarm system is installed, and in commission.³ The building owner is responsible for inspection, testing, and maintenance of the systems. This above work is permitted to be done by qualified and experienced personnel.

It appears that the inspection, testing, and maintenance for WTC 7 was performed by an outside contractor. The inspection, testing, and maintenance records were well-documented between 2000 and 2001.

5.6 COMPARISON OF WTC 7 FIRE ALARM SYSTEM TO WTC 1 AND WTC 2 FIRE ALARM SYSTEM

The fire alarm systems installed in WTC 1, 2, and 7 were consistent with the performance criteria as adopted by the Port Authority, but there were significant differences in approach in meeting these requirements. The development and implementation of the WTC 1 and WTC 2 alarm systems was approached in a methodical way. The overall fire alarm goals were identified and systematic steps developed and used for system design and installation. In comparison, documents available on the WTC 7 fire alarm system indicate that the design development for the system did not follow the approach used for WTC 1 and WTC 2. The WTC 7 fire alarm design documents consisted of basic working documents used by construction personnel for the equipment layout, which allowed the installation contractor more leeway in determining what materials were used, where devices and equipment were located, and how the system would ultimately perform. This approach does not indicate that the system design or product was substandard, it only shows that the design, hardware, and equipment layout did not follow the strict development requirements set forth by the Port Authority for WTC 1 and WTC 2. No documents were found that would indicate that the WTC 7 fire alarm system were not consistent with the performance standards required for the building.

The differences between the systems begin with the system goals. The WTC 1 and WTC 2 fire alarm system criteria placed a strong emphasis on system survivability, which was not apparent in the WTC 7

³ Fire Service Incorporated, inspection and maintenance records for the WTC over the life of the building.

system. The survivability enhancements present in the WTC 1 and WTC 2 systems that were not found in the WTC 7 system included the distribution of the fire alarm intelligence, monitoring, and controls on seven different levels. The WTC 7 fire alarm system did not use distributed intelligence. Also, the WTC 1 and WTC 2 fire alarm systems required all fire alarm riser circuits to be installed in three separate locations and within rigid conduit for additional physical protection. The WTC 7 fire alarm system documents did not indicate that this was required for the WTC 7 system. The survival of the fire alarm functions within WTC 1 and WTC 2 after impact can be directly attributed to these enhancements.

Another significant difference between the systems was the design development. Whereas the WTC 1 and WTC 2 systems had “MANDATED Fire Alarm Guidelines” (WTC 1999) as the basis for the installation of new equipment, there was no documentation available that indicated that the same controls were developed for the WTC 7 system. The advantages gained from the use of adopted guidelines are increased reliability and known performance through design and installation controls. This is especially true for large systems that undergo frequent renovations, maintenance, and repairs.

The final major difference was the commissioning and acceptance controls. The WTC 1 and WTC 2 fire alarm systems had comprehensive quality assurance procedures to maintain established performance levels for the fire alarm systems. The procedures included specific design, installation, and maintenance requirements. An example of the controls was the verification of the voice loudspeaker system capability to ensure fifty percent of the system remained operable on a floor if there was a loudspeaker circuit failure. The WTC 1 and WTC 2 design criteria provided typical circuit diagrams, design documentation, and quality assurance procedures to make sure this requirement was met. These strict quality controls were implemented because it is extremely difficult without disabling the voice circuit to verify this capability after the system is installed. The WTC 7 documentation does not indicate that this level of quality assurance was performed. The maintenance of the records for these processes provided a baseline for determining performance levels at the time of acceptance in comparison to any future date. This baseline is a major factor in maintaining system performance and availability.

The approach taken for the design, installation, and acceptance of the fire alarm system in WTC 7 was an approach that is commonly taken for commercial high rise construction. The absence of design, installation, and commissioning controls mentioned above does not indicate that common practices were not used in the development and installation of the fire system. This comparison shows the differences and enhanced measures that fire alarm system installation followed during its life-cycle to increase performance and survivability.

This page intentionally left blank.

Chapter 6

ESTIMATES OF PERFORMANCE OF THE FIRE ALARM SYSTEM ON SEPTEMBER 11, 2001

6.1 ANALYSIS DEVELOPMENT

Documenting the actual performance of the World Trade Center (WTC) 1 and WTC 2 fire alarm systems was significantly hampered by the loss of all historic documentation stored within the buildings and the loss of electronic files that were generated by the fire alarm system during the events of September 11, 2001. The analysis of the fire alarm's performance was limited to brief images of illuminated status lamps on the fire alarm system's panels located in the WTC 1 Fire Command Station (FCS), which were filmed by Goldfish Pictures during the event in 2001. Additional information was provided through interviews by National Institute of Standards and Technology (NIST) which provided information from interviews of individuals in the buildings, or in contact with people in the building during the event. The former project manager for the fire alarm installation in WTC 1 and WTC 2 was instrumental in clarifying system architecture nuances.

The performance of the WTC 7 fire alarm system was limited to the printout of the remote monitoring of the fire alarm system's alarm and condition status. The printout indicates that the system registered an alarm at 10:00 a.m.⁴ No other information has been found on the performance of the system during the event.

6.2 OBSERVATIONS

The review of the WTC 1 and WTC 2 fire alarm system performance indicated that the systems did work, but not all functions performed as intended. The factors that directly influenced the performance were which building experienced the alarm condition, WTC 1 or WTC 2, and the location of the fire alarm function in relation to the impact damage in the building.

As a baseline for understanding, the first plane impacted WTC 1 at 8:46 a.m., and floors 93 through 99 experienced extensive, immediate impact damage. The second plane impacted WTC 2 at 9:03 a.m., and floors 77 through 85 experienced extensive, immediate impact damage. The following provides observations of the fire alarm performance based upon the interviews and film documentation.

WTC 1 Interviews – NIST interviews of survivors often included discussion of whether the occupant heard or did not hear various alarm system functions during their evacuation (NIST NCSTAR 1-7⁵). The WTC 1 interviews provided the following observations on the fire alarm functions:

- There was no confirmation that audible fire alarms were broadcast above the floors of impact.

⁴ Letter from Richard Kleinman, President, AFA Protective Systems, dated July 16, 2003, based on a request by NIST.

⁵ This reference is to one of the companion documents from this Investigation. A list of these documents appears in the Preface to this report.

- There was no confirmation that the emergency voice communication system functioned on any floor within WTC 1 after the impact.
- Confirmation was provided that alarm tones (not voice messages) were heard on the floors below impact.⁶ Fourteen percent of occupants in WTC 1 and 11 percent in WTC 2 reported hearing alarm tones in the building (NIST NCSTAR 1-7).
- There was no confirmation that the floor warden or firefighter telephone system functioned after impact.

WTC 1 Film Observations- The Goldfish Picture video provided brief images of the fire alarm visual status indicators, along with a timeline to reference the observations. Although the images were limited, the following provides a timeline of the observations:

- 8:59 a.m. – The WTC 1 Fire alarm panel general alarm visual indication and system fault visual indications are illuminated. Speaker zones 84 and 89 also indicate that they are in a fault condition. The majority of speaker zone lamps on the WTC 1 fire alarm panel are illuminated solid red, which indicates that the speaker zones illuminated are in use. Floors 1 through 84 appear to have their zones illuminated, which indicates activated speakers. The exact floors may not be correct because the analysis of the visual indicators was from the personal memory of the fire alarm project manager and was not in comparison with as-built documentation (Drucker 2004). It is not known if a voice command, or an alarm tone was broadcast over the activated speaker zones. It is not known if all speaker zones were activated, but the interview transcripts indicate that no alarm tones or voice messages were heard above the floors of impact.
- 9:06 a.m. – The alarm slow whoop tone was heard in the lobby.
- 9:58 a.m. – The visual indicators on the Concourse and Sub-Grade fire alarm panels indicate that they are in alarm and their notification appliances have been silenced.
- 9:59 a.m. – WTC 2 collapsed, and all video of the fire alarm panels ceased.

WTC 2 911 Call Recordings – 911 calls from WTC 2 provided the following observations on the fire alarm functions:

- Confirmation was provided that voice messages and alarm tones were broadcast before and after the impact, and were heard above the impact floors.⁷

⁶ NIST Interview data set 2004 and New York City 911 Emergency Call Recording, 2001.

⁷ New York City 911 Emergency Call Recordings, 2001.

WTC 2 Film Observations- The Goldfish Pictures video (Fig. 6–1) taken inside WTC 1 also provided brief images of the fire alarm visual status indicators, along with a timeline to reference the observations. Although the images were limited, the following provides a timeline of the observations:

- 9:58 a.m. – The WTC 2 fire alarm panels indicate that the floor warden telephones on floors 64, 71, 73, 93, and 99 are in use. Also, zones 76 through 84 on the speaker zones, warden telephone zones and fireman telephones zones are in a fault condition (see Fig. 6–1). Again, the zone numbers are based upon the fire alarm project manager’s memory and may not be exactly correct (Drucker 2004). But, the sequential number of the zones correspond closely with the floors served by the PSR panels located on floors 74, 79, and 83. It is believed that the PSR panels were damaged, and the MXL-VR remote panel supporting the PSR panels maintained communication with the head-end MXL-V in the FCS to report the damage.
- 9:59 a.m. – WTC 2 collapsed, and all video of the fire alarm panels ceased.



Figure 6–1. WTC 2 speaker and telephone circuit faults.

Other images of the fire alarm panels for both buildings did not indicate fault conditions on the impact floors or the floors above. This absence of numerous visual indicators may have been due to the loss of the communication paths to the remote MXL-VR panels, or PSR panels, or the loss of the panels themselves. The fact that the WTC 2 fire alarm system was able to continue to provide voice communication capability and floor warden telephones after the impact was probably due to Stair C remaining partially intact after the impact, which was where a portion of the audible riser was located, and the survival of the riser in the core area where the telephone riser was located. Of further interest is the visual indication on the FCS fire alarm panel that indicated that the WTC 2 fire alarm system lost communication to a group of PSR panels. Why the PSR panels lost communication is not known, but it

would be reasonable to expect physical damage to the circuits. If the MNET circuits were damaged beyond use, survival of the audible circuits is difficult to explain. The audible circuit did survive since some occupants did hear voice announcements. The performance of other system functions and components within the system were not verifiable without the recovery of records lost with the buildings.

6.2.1 Summary of Results

The analysis of the fire alarm systems performance has led to the following results:

- Remote monitoring of the WTC 7 fire alarm systems only provided a time and date of the alarm condition (see Fig. 6-2)⁴.
- The WTC 1 and WTC 2 fire alarm system required manual activation of the alarm signal to notify building occupants. This signal was delayed by 12 minutes after the impact in WTC 1.
- Although there is evidence that the floor warden telephones were used, the after action interviews of the firefighters conducted by NIST did not find that there was any attempt to use the firefighter telephone system. This is not uncommon since the firefighters are trained to use their radios as the preferred means of communication.
- Although the fire alarm systems in WTC 1 and WTC 2 used multiple communication path risers, the systems experienced performance degradation, especially in WTC 1 where all fire alarm notification and communication functions appears to have been lost above the floors of impact.

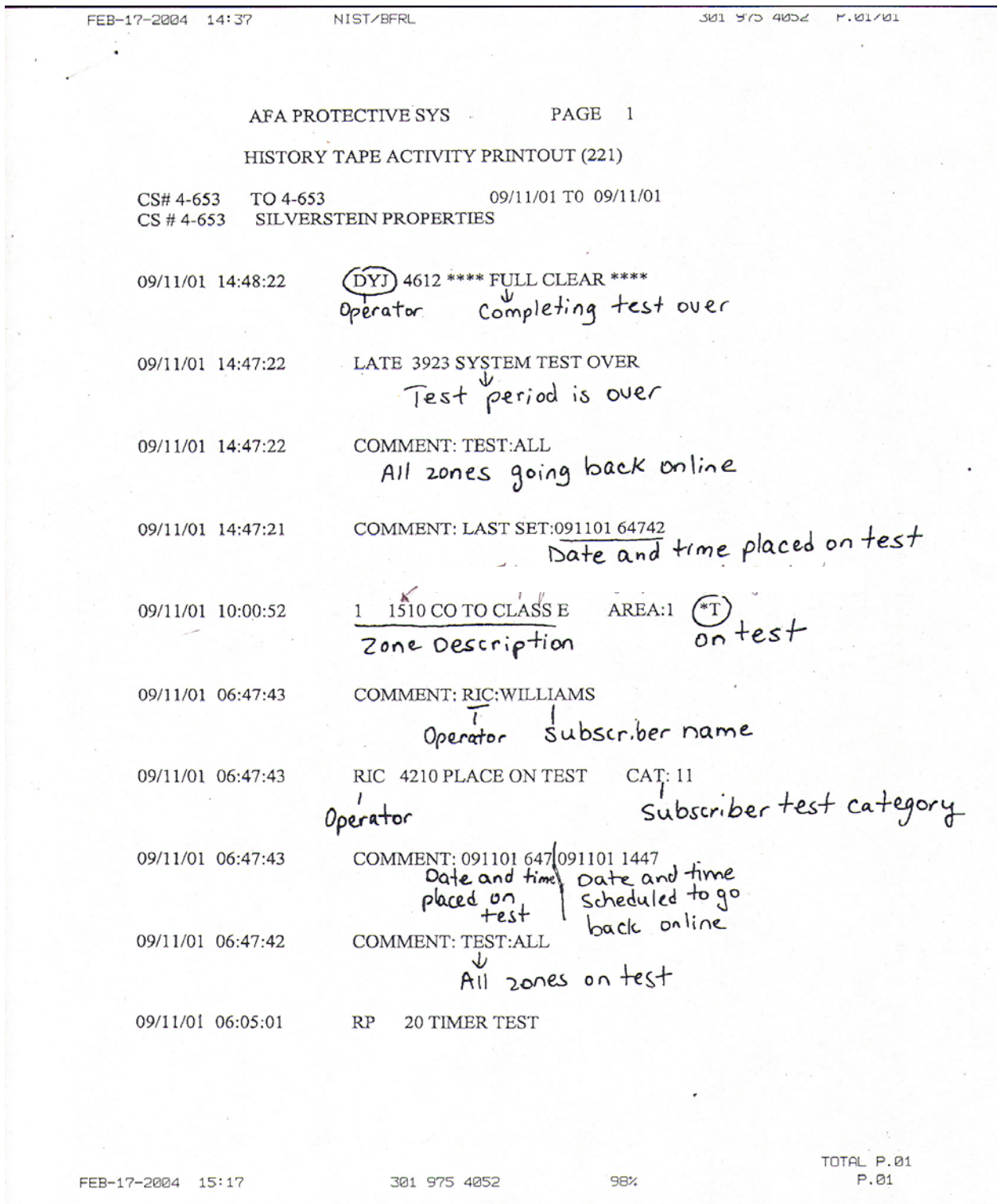

Figure 6-2. WTC 7 central station alarm log.

This page intentionally left blank.

Chapter 7

REFERENCES

- Boyle, R. 1999. The Port Authority of New York and New Jersey, New York, NY, personal communication to All Commissioners, WTC fire alarm system tenant design requirements – adoption of best industry practices. May 11.
- Buchsbaum, J., and J. Mizrahi. 1994. *Retrofitting the World Trade Center Fire Alarm System*. The Port Authority of New York and New Jersey. New York, NY, November.
- DiChiara, R. 1993. The Port Authority of New York and New Jersey, New York, NY, personal communication to T. Cancelliere, R. Cronin, C. Maikish, A. Reiss, and G. Rossi, Subgrade fire and life safety enhancements – assignment of responsibilities. December 30.
- Drucker, J. 2001. *Presentation on the World Trade Center Fire Alarm System*. Siemens Building Technologies.
- Drucker, J. 2001. *Remembering the World Trade Center*. October.
- Drucker, J. 2004. Personal Communications.
- Isner, M., and T. J. Klem. 1993. *World Trade Center Explosion and Fire*. National Fire Protection Association. February 26.
- Manning, W. *The World Trade Center Bombing: Report and Analysis*. Fire Engineering.
- Marchese, P. 1993. The Port Authority of New York and New Jersey, New York, NY, personal communication to E. Ramabhushanam, WTC – New WTC fire alarm system. July 21.
- McGuire, J.H., and B. E. Ruscoe. 1962. *The Value of a Fire Detector in the Home*, National Research Council of Canada, Fire Study No. 9 of the Division of Building Research, Ottawa, Canada.
- Merritt & Harris, Inc. 2000. *Property Condition Assessment of World Trade Center Portfolio*. Property #1. New York, NY, December 6.
- Merritt & Harris, Inc. 2000. *Property Condition Assessment of World Trade Center Portfolio*. Property #2. New York, NY, December 6.
- Mizrahi, J. *The World Trade Center Fire Alarm System Before & After*. PANYNJ (The Port Authority of New York and New Jersey).
- Monti, R. M. 1979. Personal communication to G. F. Tozzoli, World Trade Department, WTC – Towers A & B – fire safety program. February 5.
- National Fire Protection Association (NFPA). 2002. *NFPA 72, National Fire Alarm Code*.

- PACO Group, Inc. and Flack & Kurtz, Inc. 2002. *Final Preliminary Report – General Description of All Building Systems and the Capital Program*. January 14.
- PANYNJ (The Port Authority of New York and New Jersey). 2002. *World Trade Center Fire Safety Plan*. New York, NY, November.
- PANYNJ (The Port Authority of New York and New Jersey). 2000. *The World Trade Center, New Fire Alarm System Increase in Project Authorization*. New York, NY, July 27.
- PANYNJ (The Port Authority of New York and New Jersey). 1999a. *World Trade Center, Base Building Fire Alarm System*. March 1.
- PANYNJ (The Port Authority of New York and New Jersey). 1999b. *World Trade Center – Code Compliance Evaluation, New York, NY October 15*.
- PANYNJ (The Port Authority of New York and New Jersey). 1998. *Design Guidelines, Specifications and Standard Details Program*. New York, NY, May 11.
- PANYNJ (The Port Authority of New York and New Jersey). 1997. *Tenant Construction Review Manual*. New York, NY, March.
- PANYNJ (The Port Authority of New York and New Jersey). 1988. *Fire Safety Plan for 7 World Trade Center*. April 18.
- PANYNJ (The Port Authority of New York and New Jersey). 1986. *World Trade Center Instruction Manual No. 23, Operation and Maintenance of Fire Protection System*. New York, NY, February.
- PANYNJ (The Port Authority of New York and New Jersey). 1984. *Fire Communications and Alarm System for Fire and Life Safety*. October 22.
- PANYNJ (The Port Authority of New York and New Jersey). 1984. *Intercommunication System*. October 22.
- PANYNJ (The Port Authority of New York and New Jersey). 1984. *Power, Control and Alarm Wiring Systems*. October 22.
- PANYNJ (The Port Authority of New York and New Jersey). 1979. *Egress Facilities Serving the WTC Concourse A Re-Analysis, Considering Current Occupancy*. December.
- PANYNJ (The Port Authority of New York and New Jersey). 1971. *Tenant Construction Review*. New York, NY.
- PANYNJ (The Port Authority of New York and New Jersey). *New Fire Alarm System, Increase in Project Authorization*. July 27.
- PANYNJ (The Port Authority of New York and New Jersey). Personal communication to R. Jensen, Largo, FL, WTC Report Update Project – N10140.07. December 4.

- PANYNJ (The Port Authority of New York and New Jersey). *System Narrative for Fire Alarm and Communication Systems for the World Trade Center*.
- PANYNJ (The Port Authority of New York and New Jersey). *Section 16910 – Fire Alarm Speaker, Strobe and ALD Loop, Field Testing of Wiring*.
- PANYNJ (The Port Authority of New York and New Jersey). *Chapter 4 – Fire Alarm System*.
- PANYNJ (The Port Authority of New York and New Jersey). *WTC – Changes to Evacuation Systems After 1993*.
- Reiss, A. 1993. World Trade Center, New York, NY, personal communication to J. McCormick, Rolf Jensen & Associates, Inc., Springfield, NJ, Enclosing copy of specifications and system narrative for the new Pyrotronics Fire Alarm System, WTC Tenant Guidelines dealing with firestopping, and WTC standard detail drawings. August 3.
- Rivera C., and R. Rinaldi. 1993. The City of New York Fire Department, Brooklyn, NY, personal communication to D. Dinkins, Mayor, New York, NY, Fire and Building Codes and the Jurisdiction and Compliance of Federal, State, State Authorities and Foreign Government Buildings report. March 25.
- Rohlfing, T. 1993. The City of New York Fire Department, Brooklyn, NY, personal communication to J. Commiskey, World Trade Center – PA, New York, NY, Comments from our electrical unit. July 13.
- Rolf Jensen & Associates, Inc. (RJA). 2003. *World Trade Center Investigation – Task 2A – WTC Towers 1 & 2 Fire Protection Summary*. October 22.
- SafirRosetti Omnicom Group, Inc. 2002. *Expert Report of Howard Safir*. August 1.
- Sbarra, V. 1993. Gage-Babcock & Associates, Inc., New York, NY, personal communication to Keenan, D., Hamond & Regine, Mineola, LI, New York, Port Authority of NY & NJ Loss Control Report – World Trade Center Complex. April 27.
- Semah, C. 1996. The Port Authority of New York and New Jersey, New York, NY, personal communication to A. Reiss, WTC F.A. system – system features and capabilities. October 1.
- Sileo, M. 1987. World Trade Center, New York, NY, personal communication to All Two World Trade Center Tenants on Floors 17 through 26, New York, NY, The World Trade Center fire alarm system. August 18.
- Syska & Hennessy. 1984. *Basic Design Schematic for 7 World Trade Center*. November 5.
- Visconti, R. 1993. The City of New York Department of Buildings, New York, NY, personal communication to unknown distribution, Existing Approved Class E and Modified Class E fire alarm systems: extension of A and B speaker circuits in lieu of speaker supervision in existing high-rise office buildings. February 26.

Visconti, R. 1994. The City of New York Department of Buildings, New York, NY, personal communication to M. Jachniewicz, Material and Equipment Acceptance Division, Fire alarm wiring. October 3.

Visconti, R. 1995. The City of New York Department of Buildings, New York, NY, personal communication to unknown distribution, "Grace Period" for the use of fluoropolymer "Teflon Equivalent" cables previously accepted by the department. May 9.

Visconti, R. 1995. The City of New York Department of Buildings, New York, NY, personal communication to unknown distribution, Using of fluoropolymer "Teflon" type cabling/wiring in fire alarm systems. May 9.

World Trade Center Fire Prevention and Life Safety Unit. 2001. *Emergency Procedures Manual 2001*. New York, NY.

World Trade Center Fire Prevention and Life Safety Unit. 2002. *Tenant Fire Safety Guide*. New York, NY.