

THIS FILE IS MADE AVAILABLE THROUGH THE DECLASSIFICATION EFFORTS AND RESEARCH OF:

# THE BLACK VAULT

THE BLACK VAULT IS THE LARGEST ONLINE FREEDOM OF INFORMATION ACT / GOVERNMENT RECORD CLEARING HOUSE IN THE WORLD. THE RESEARCH EFFORTS HERE ARE RESPONSIBLE FOR THE DECLASSIFICATION OF THOUSANDS OF DOCUMENTS THROUGHOUT THE U.S. GOVERNMENT, AND ALL CAN BE DOWNLOADED BY VISITING:

[HTTP://WWW.BLACKVAULT.COM](http://www.blackvault.com)

YOU ARE ENCOURAGED TO FORWARD THIS DOCUMENT TO YOUR FRIENDS, BUT PLEASE KEEP THIS IDENTIFYING IMAGE AT THE TOP OF THE .PDF SO OTHERS CAN DOWNLOAD MORE!



PUBLIC AFFAIRS

OFFICE OF THE ASSISTANT TO THE SECRETARY OF DEFENSE  
1400 DEFENSE PENTAGON  
WASHINGTON, D.C. 20301-1400



09 MAY 1994

Ref: 93-F-1491

Mr. David A. Charmicheal

[REDACTED]  
[REDACTED]  
[REDACTED]  
ENGLAND

Dear Mr. Charmicheal:

This responds to your May 27, 1993, Freedom of Information Act (FOIA) request pertaining to an updated version of JSCP 20, Volume II. Our June 9 letter, your June 25 letter, and our July 6 interim response refer.

Due to the size and complexity of the Department of Defense (DoD), there is no central repository for all DoD records. This Directorate is responsible for responding to requests for records of the components of the Office of the Secretary of Defense and the Joint Staff (OSD/JS). The several components of the DoD, including the military departments and separate defense agencies, operate their own Freedom of Information offices to respond to requests for records for which they are responsible. These procedures are provided in DoD Regulation 5400.7-R, as published at 32 CFR 286.

In accordance with those procedures, we have categorized your request as "other". "Other" category requesters receive the first two hours search time and 100 pages of documents at no charge. Established DoD fees are: clerical search, \$12 per hour; professional search, \$25 per hour; executive search, \$45 per hour; computer search, varies according to the system used, billed per minute; microfiche, \$0.25 per page; office copy reproduction, \$0.15 per page; and printed publications or reports, \$0.02 per page.

The Joint Staff has provided the enclosed 238 page record as responsive to your request. The Joint Staff advised that Joint Publication 3-05.3, *Joint Special Operations Operational Procedures*, supersedes JCS Pub 20, Volume II, 20 May 1983.

The administrative cost of processing this request was \$91.95. Having provided two hours search and 100 pages of reproduction at no charge, the remaining chargeable cost consists of 138 pages of office copy reproduction at \$0.15 per page. (\$35.70 for 238 pages, minus \$15.00 for 100 free pages, equals \$20.70 chargeable.)

HL-05

Please indicate our reference number, **93-F-1491**, on a check or money order made payable to the U.S. Treasurer in the amount of **\$20.70**. To avoid interest charges, payment must be received in this Directorate within 30 calendar days of this letter's date. Our new address is:

Office of the Assistant to the Secretary of Defense  
(Public Affairs)

Directorate for Freedom of Information and  
Security Review, Room 2C757  
1400 Defense Pentagon,  
Washington, DC 20301-1400

Sincerely,



D. J. Blakeslee  
Acting Director  
Freedom of Information  
and Security Review

Enclosure

**JOINT PUB 3-05.3**

---



**JOINT SPECIAL  
OPERATIONS  
OPERATIONAL PROCEDURES**



**25 AUGUST 1993**



A large body of joint doctrine (and its supporting tactics, techniques, and procedures) has been and is being developed by the US Armed Forces through the combined efforts of the Joint Staff, Services, and combatant commands. The following chart displays an overview of the development process for these publications.

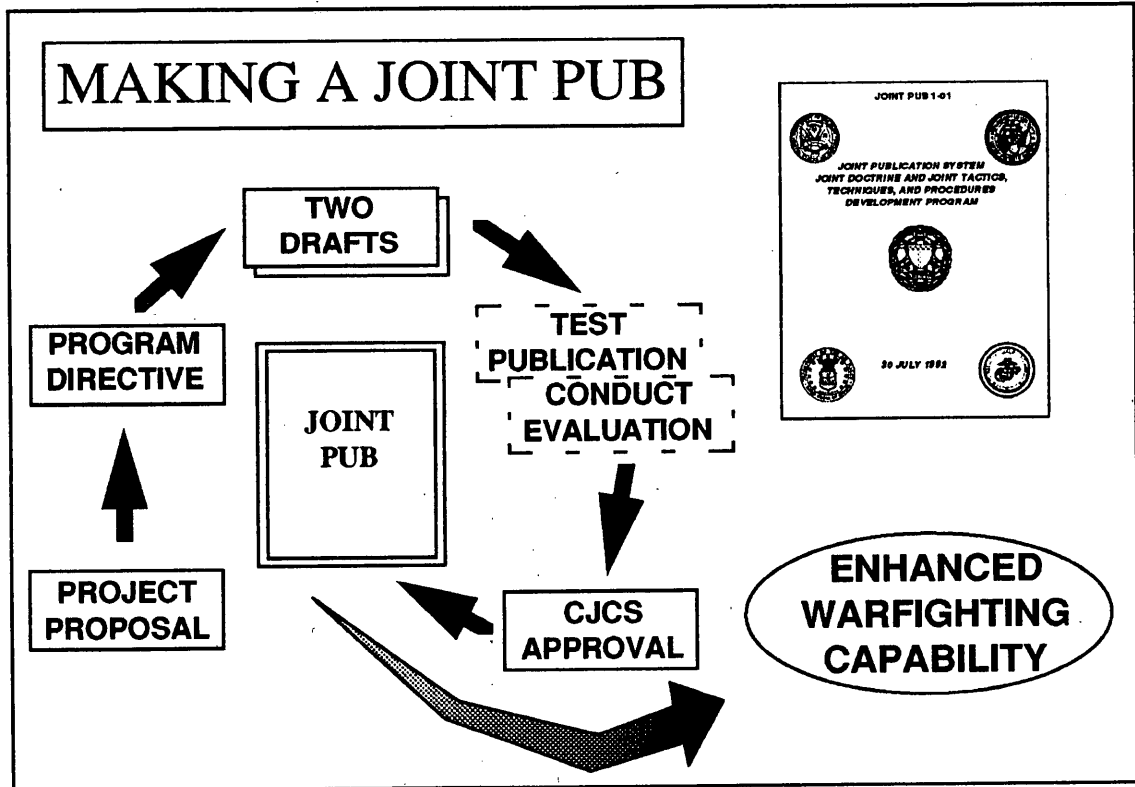

All joint doctrine and tactics, techniques, and procedures are organized into a comprehensive hierarchy. Joint Pub 3-05.3 is located in the operations series of joint publications.

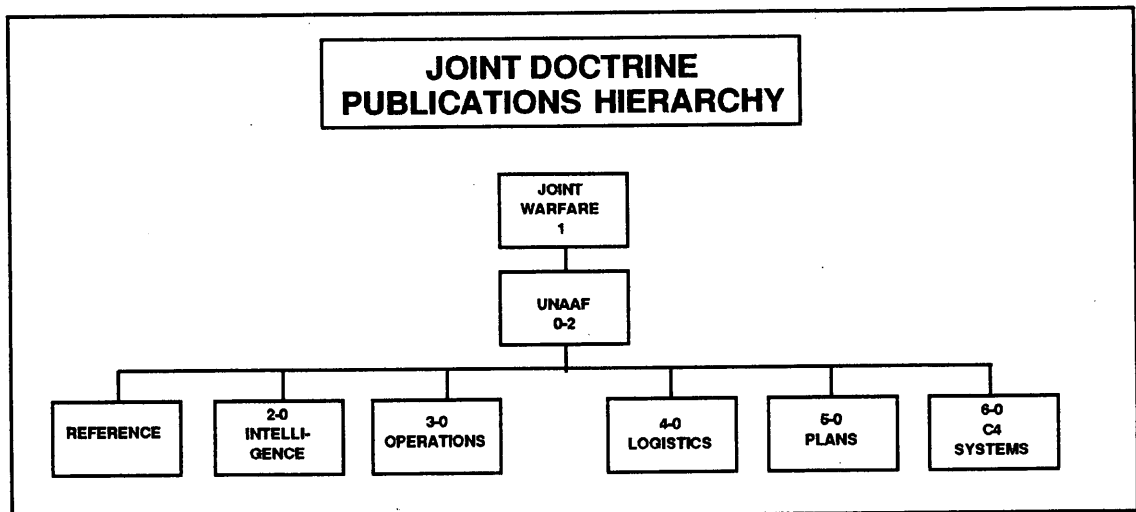

Joint Pub 1-01, "Joint Publication System," provides a detailed list of all joint publications. Joint pubs are also available on CD-ROM through the Joint Electronic Library (JEL). For information, contact: Joint Doctrine Division, J-7, Joint Staff, Washington, D.C. 20318-7000.



**OFFICE OF THE CHAIRMAN**  
**THE JOINT CHIEFS OF STAFF**  
WASHINGTON, D.C. 20318-0001

Reply ZIP Code:  
20318-0400

Joint Pub 3-05.3  
25 August 1993

MEMORANDUM FOR: Distribution List

Subject: Joint Publication 3-05.3, "Joint Special Operations  
Operational Procedures"

1. This publication has been prepared under the direction of the Chairman of the Joint Chiefs of Staff. It sets forth doctrine and tactics, techniques, and procedures to govern the joint activities and performance of the Armed Forces of the United States.
2. Recommendations for changes to this publication should be submitted to the Director for Operational Plans and Interoperability (J-7), 7000 Joint Staff, Pentagon, Washington, D.C. 20318-7000.
3. When a Joint Staff directorate submits a proposal to the Chairman of the Joint Chiefs of Staff that would change source document information reflected in this publication, that directorate will include a proposed change to this publication as an enclosure to its proposal.
4. The Military Services and other organizations are requested to notify the Director, J-7, Joint Staff, when changes to source documents reflected in this publication are initiated.
5. Additional copies of this publication can be obtained through Service publication centers.
6. This publication supersedes JCS Pub 20, Volume II, 20 May 1983.
7. Local reproduction is authorized and access to this unclassified publication is unrestricted. However, access to and reproduction authorization for classified joint publications must be in accordance with DoD Regulation 5200.1-R.
8. The lead agent for this publication is the Commander in Chief, US Special Operations Command.

8. Only approved pubs and test pubs are releasable outside the combatant commands, Services, and Joint Staff. Release of any joint publication to foreign governments or foreign nationals must be requested through the local embassy (Defense Attache Office) to DIA Foreign Liaison Branch, C-AS1, Room 1A674, Pentagon, Washington, D.C. 20301-6111.

9. The lead agent for this publication is the Commander in Chief, US Special Operations Command.

10. The Joint Staff doctrine sponsor for this publication is the Director for Operations, Operations Directorate, J-3.

For the Chairman of the Joint Chiefs of Staff:



T. R. PATRICK  
Colonel, USA  
Secretary, Joint Staff

Enclosure

Distribution:

By Secretary, Joint Staff:

Joint Staff	OSD	NSA	CIA	JWC	USELMNORAD
FEMA	DISA	DIA	DLA	DMA	DNA
NDU	MCCDC	JEWC	AFSC	JDC	DISA-JIEO
CIO	JWFC				

Additional copies may be obtained from the Secretary, Joint Staff (Documents Division).

Five copies each to: Offices of CSA, CNO, CSAF, CMC, USCG

Twenty-five copies each to:

USLANTCOM	USCENTCOM	USEUCOM	FORSCOM
USPACOM	USSOUTHCOM	USSPACECOM	
USSOCOM	USSTRATCOM	USTRANSCOM	

Additional copies should be obtained from the Military Service assigned administrative support responsibility by DOD Directive 5100.3, 1 November 1988, "Support of the Headquarters of Unified, Specified, and Subordinate Joint Commands."

By Military Services:

Army: US Army AG Publication Center  
2800 Eastern Boulevard  
Baltimore, MD 21220-2898

Air Force: Air Force Publications Distribution Center  
2800 Eastern Boulevard  
Baltimore, MD 21220-2896

Navy: CO, Navy Aviation Supply Office  
Distribution Division (Code 03443)  
5801 Tabor Ave  
Philadelphia, PA 19120-5000

Marine Corps: Marine Corps Logistics Base  
Albany, GA 31704-5000

Coast Guard: Coast Guard Headquarters, COMDT (G-REP)  
2100 2nd Street, SW  
Washington, D.C. 20593-0001



(INTENTIONALLY BLANK)



## LIST OF EFFECTIVE PAGES

The following is a list of effective pages. Use this list to verify the currency and completeness of your document. An "O" indicates a page in the original document.

PAGE	CHANGE	PAGE	CHANGE
i thru x	O	E-1 thru E-12	O
I-1 thru I-4	O	F-1 thru F-6	O
II-1 thru II-8	O	G-1 thru G-2	O
III-1 thru III-12	O	H-1 thru H-4	O
IV-1 thru IV-12	O	J-1 thru J-16	O
V-1 thru V-16	O	K-1 thru K-4	O
VI-1 thru VI-6	O	L-1 thru L-6	O
VII-1 thru VII-14	O	M-1 thru M-4	O
VIII-1 thru VIII-8	O	N-1 thru N-4	O
A-1 thru A-6	O	O-1 thru O-12	O
B-1 thru B-12	O	P-1 thru P-2	O
C-1 thru C-10	O	Q-1 thru Q-4	O
D-1 thru D-2	O	R-1 thru R-10	O
		GL-1 thru GL-28	O

Deleted Pages: None.

## JOINT SPECIAL OPERATIONS OPERATIONAL PROCEDURES

## PREFACE

1. Purpose. This publication sets forth doctrine (or doctrine and selected tactics, techniques, and procedures) to govern the joint activities and performance of the Armed Forces of the United States in joint operations as well as the doctrinal basis for US military involvement in multinational and interagency operations. It provides military guidance for the exercise of authority by combatant commanders and other joint force commanders and prescribes doctrine (or JTTP) for joint operations and training. It provides military guidance for use by the Armed Forces in preparing their appropriate plans. It is not the intent of this publication to restrict the authority of the joint force commander (JFC) from organizing the force and executing the mission in a manner the JFC deems most appropriate to ensure unity of effort in the accomplishment of the overall mission.

2. Application

a. Doctrine (or JTTP) and guidance established in this publication apply to the commanders of combatant commands, subunified commands, joint task forces, and subordinate components of these commands. These principles and guidance also may apply when significant forces of one Service are attached to forces of another Service or when significant forces of one Service support forces of another Service.

b. In applying the doctrine (or JTTP) set forth in this publication, care must be taken to distinguish between distinct but related responsibilities in the two channels of authority to forces assigned to combatant commands. The Military Departments and Services recruit, organize, train, equip, and provide forces for assignment to combatant commands and administer and support these forces. This authority is, by law, subject to the provisions of title 10, United States Code, Chapter 6, which is the section that details the authority of combatant commanders. Commanders of the unified and specified commands exercise combatant command (command authority) over their assigned forces. Service component commanders are subject to the orders of combatant commanders and, subject to the combatant commander's direction, are also responsible to the Military Departments and Services in the exercise of their administrative and support responsibilities.

c. This publication is authoritative but not directive. Commanders will exercise judgment in applying the procedures herein to accomplish their missions. This doctrine (or JTTP) should be followed except when, in the judgment of the commander, exceptional circumstances dictate otherwise. If conflicts arise between the contents of this publication and the contents of Service publications, this publication will take precedence for the activities of joint forces unless the Chairman of the Joint Chiefs of Staff, normally in coordination with the other members of the Joint Chiefs of Staff, has provided more current and specific guidance. Commanders of forces operating as part of a multinational (alliance or coalition) military command should follow multinational doctrine and procedures ratified by the US. For doctrine and procedures not ratified by the US, commanders should evaluate and follow the multinational command's doctrine and procedures, where applicable.

3. Scope. Joint SO doctrine and TTP represent a body of knowledge derived from operational experience. The doctrine and TTP within this publication apply to the planning, conduct, and support of joint SO across the operational continuum. This publication focuses on the activities of the Joint Force Special Operations Component Commander (JFSOCC). At theater level, the JFSOCC is normally the commander of the theater special operations command (COMSOC). For subordinate joint forces, the JFSOCC is normally the commander of a joint special operations task force (JSOTF). The term JFSOCC is a generic term that refers to both the theater COMSOC and the commander of a JSOTF reporting to a joint force commander (JFC) subordinate to the theater combatant commander.

a. The TTP in this publication provide the linkage between the principles and doctrine set forth in Joint Pub 3-05 and the detailed Service guidance for unit-level tactical operations. Appendix A lists SO-related joint and Service publications.

b. This publication describes operational procedures for the joint functional SO component of a joint force. SOF require a coherent body of TTP not only to serve as the basis for joint SO, but also to enhance coordination with conventional components. Joint SO TTP facilitate the training of assigned SOF, improve joint interoperability, assist the identification of SO-peculiar requirements, and foster awareness of SO. The information within this publication is dedicated to these goals and should be informative for the commanders of conventional forces as well as instructive to those within the SO community.

c. This publication does not address the planning, conduct, and support of uni-Service special operations. Neither does it address psychological operations or civil affairs except as these activities relate to joint SO. (Joint Pubs 3-53 and 3-57 contain doctrine for joint PSYOP and CA activities.)

4. Basis. The following primary sources provide the basis for developing this publication:

a. Joint Pub 0-2, 1 December 1986, "Unified Action Armed Forces (UNAAF)."

b. Joint Pub 1-01, 30 July 1992, "Joint Publication System, Joint Doctrine and JTTP Development Program."

c. Joint Pub 2-0, "Doctrine for Intelligence Support of Unified and Joint Operations." (In development)

d. Joint Pub 3-0, "Doctrine for Joint Operations." (In development)

e. Joint Pub 3-05, 28 October 1992, "Doctrine for Joint Special Operations"

f. Joint Pub 3-05.5, 10 August 1993, "Joint Special Operations Targeting and Mission Planning Procedures."

g. Joint Pub 4-0, 25 September 1992, "Doctrine for Logistic Support of Joint Operations."

h. Joint Pub 5-0, "Doctrine for Planning Joint Operations." (In development)

i. Joint Pub 6-0, 3 June 1992, "Doctrine for Command, Control, Communications, and Computer (C4) Systems Support to Joint Operations."

(INTENTIONALLY BLANK)

TABLE OF CONTENTS

CHAPTER	PAGE
I INTRODUCTION.....	I-1
General.....	I-1
Uniqueness of SOF.....	I-1
Joint Special Operations.....	I-2
Role of USCINCSOC.....	I-2
Role of Theater Combatant Commander.....	I-2
Role of Theater COMSOC.....	I-3
Role of Theater Service Component Commander.....	I-3
II MISSIONS AND CAPABILITIES.....	II-1
General.....	II-1
Unconventional Warfare.....	II-1
Direct Action.....	II-2
Special Reconnaissance.....	II-3
Foreign Internal Defense.....	II-5
Counterterrorism.....	II-6
Collateral Activities.....	II-7
Operational Mission Taskings.....	II-7
Operational Training.....	II-7
Conventional Applications of SOF.....	II-8
Other Forces Trained and Equipped to Support SO.....	II-8
III COMMAND AND CONTROL OF SPECIAL OPERATIONS.....	III-1
General.....	III-1
The Theater Special Operations Command.....	III-1
Army SOF.....	III-1
Navy SOF.....	III-4
Air Force SOF.....	III-5
Joint Special Operations Air Component.....	III-5
Joint Special Operations Task Force.....	III-5
Transfer of Forces.....	III-6
SO and Air Operations.....	III-7
SO and Land Operations.....	III-9
SO and Maritime Operations.....	III-10
IV PLANNING SPECIAL OPERATIONS.....	IV-1
General.....	IV-1
Maintenance of Theater Perspective.....	IV-1
Deliberate Planning.....	IV-1
Supporting Plan Development.....	IV-2
Time-Sensitive Planning.....	IV-4
Peacetime Planning.....	IV-4



Planning Standards.....	IV-7
UW Planning Considerations.....	IV-7
DA Planning Considerations.....	IV-9
SR Planning Considerations.....	IV-11
FID Planning Considerations.....	IV-11
CT Planning Considerations.....	IV-12
 V CONDUCTING SPECIAL OPERATIONS.....	V-1
General.....	V-1
Peacetime Activities.....	V-1
Conflict.....	V-3
Crisis Response.....	V-4
War.....	V-4
Mission Execution.....	V-7
Concept Development.....	V-8
Briefbacks.....	V-8
Rehearsals.....	V-8
Communications.....	V-11
Execution Checklist.....	V-12
Command and Control.....	V-12
Mission Deconfliction.....	V-13
Mission Evaluation.....	V-15
 VI INTELLIGENCE SUPPORT OF SPECIAL OPERATIONS.....	VI-1
General.....	VI-1
SO Intelligence Requirements.....	VI-1
Collection Management.....	VI-1
Analysis and Production.....	VI-2
Dissemination.....	VI-3
Intelligence Communications.....	VI-4
Counterintelligence.....	VI-4
Intelligence Support to SO Planning.....	VI-4
 VII C4 SYSTEMS SUPPORT OF SPECIAL OPERATIONS.....	VII-1
General.....	VII-1
SOF Communications Capabilities.....	VII-1
Automated Planning Tools.....	VII-2
Baseline SOF C4 Systems.....	VII-2
ARSOF C4 Systems.....	VII-4
NSWTG C4 Systems.....	VII-6
AFSOC C4 Systems.....	VII-8
JFSOCC C4 Systems.....	VII-8
Communications Planning Considerations.....	VII-10
 VIII LOGISTIC SUPPORT OF SPECIAL OPERATIONS.....	VIII-1
General.....	VIII-1

Logistic Policies.....	VIII-1
Responsibilities.....	VIII-2
Logistic Planning.....	VIII-3
Logistic Functions.....	VIII-4
Logistic Reporting.....	VIII-6
Logistic Communications.....	VIII-6
SO Bases and Facilities.....	VIII-6
Combined or Indigenous SO Logistic Support....	VIII-7
ARSOF Logistic Support.....	VIII-7
AFSOF Logistic Support.....	VIII-8
NAVSOF Logistic Support.....	VIII-8

APPENDIX

A	References.....	A-1
B	JFSOCC (SOC) Internal Organization.....	B-1
C	Joint Operations Center.....	C-1
D	Liaison Officer Procedures.....	D-1
E	SOF Message Formats.....	E-1
F	Peacetime Planning Agencies.....	F-1
G	Execution Checklist.....	G-1
H	Standard SO Mission Designation.....	H-1
I	Not Used.	
J	SOF Logistic Planning Checklist.....	J-1
K	Other Forces Trained and Equipped to Support SO....	K-1
L	Psychological Operations.....	L-1
M	Civil Affairs.....	M-1
N	Legal Aspects of Special Operations.....	N-1
O	Health Service Support.....	O-1
P	Personnel Functions.....	P-1
Q	Deployment.....	Q-1
R	Users Evaluation Report.....	R-1

GLOSSARY

Part I--Abbreviations and Acronyms.....	GL-1
Part II--Terms and Definitions.....	GL-7

FIGURE

III-1	Notional Theater Organization.....	III-2
III-2	Notional JFSOCC Command Relationships.....	III-3
V-1	Sample Mission Status Matrix.....	V-9
V-2	Sample Mission Support Matrix.....	V-10
VII-1	Interfaces for SOF C4.....	VII-3
VII-2	Notional Deployed ARSOF C4 Systems.....	VII-5
VII-3	Notional Deployed NSWTG C4 Systems.....	VII-7
VII-4	Notional Deployed AFSOC C4 Systems.....	VII-9
VII-5	Phase ALPHA C4 Support.....	VII-11
VII-6	Phase BRAVO C4 Support.....	VII-12

VII-7	Phase CHARLIE C4 Support.....	VII-13
B-1	Typical JFSOCC Staff Organization.....	B-3
C-1	Typical JOC Organization.....	C-2
C-2	Typical JOC Physical Arrangement.....	C-3
G-1	Sample Execution Checklist.....	G-2
O-1	SOF HSS Planning Aid.....	O-9

## CHAPTER I

## INTRODUCTION

". . . first, break down the wall that has more or less come between special operations forces and the other parts of our military . . . second, educate the rest of the military; spread a recognition and an understanding of what you do, why you do it, and how important it is that you do it. Last, integrate your efforts into the full spectrum of our military capability."

Admiral William J. Crowe, Jr.  
USSOCOM Activation Ceremony  
1 June 1987

1. General. Successful SO depend upon three factors: clear national and theater strategic objectives, effective C4I and support at the operational level, and competent tactical planning and execution. This publication provides guidance for operational-level joint and Service headquarters conducting and supporting joint SO. The first chapter presents SO in the context of other joint operations and describes the role of USCINCSOC, theater combatant commander, COMSOC, and theater Service component commanders in joint SO. Chapter II discusses SO missions and SOF capabilities from the perspective of the theater COMSOC. Chapter III discusses the C2 of SO. Chapter IV covers operational supervision of SO mission planning. Chapter V discusses how a JFSOCC controls SO mission execution. Chapters VI, VII, and VIII discuss the intelligence, communications, and logistic support of joint SO.

2. Uniqueness of SOF. SOF are unique because they provide the National Command Authorities (NCA) a broad range of capabilities that can be of great utility across the entire operational continuum. SOF are particularly useful as an instrument of national power when international circumstances call for a US military response less than the commitment of conventional military combat forces. During hostilities, SOF enhance the power and scope of joint operations and tend to be asymmetrical in their application. Innovative SO can directly and indirectly attack enemy centers of gravity that may be difficult to reach by conventional action. SOF support other forces in operations such as intelligence collection, target acquisition and designation, and interdiction, but they also frequently require support by other forces. Their capabilities are vast, but they must be employed judiciously to avoid negating their effectiveness. SOF are not a substitute for conventional forces.

3. Joint Special Operations. The terms SO and SOF are often used interchangeably, but they have discrete meanings. SO refers to missions and activities, while SOF refers to units and personnel. SO are joint from two perspectives.

a. From the point of view of the theater combatant commander, the theater JFSOCC is a functional component commander responsible for synchronizing SO with the military operations of the other theater component commanders to accomplish specific theater objectives according to an integrated theater strategy. History and operational experience teach that successful planning and conduct of joint SO require dedicated functional joint headquarters.

b. From the perspective of the theater JFSOCC, each SO mission requires a tailored mix of Service SOF capabilities to help ensure mission success. The JFSOCC must package his forces for each mission in a fashion similar to the way the Air Force component commander packages aircraft for a strike mission. Once identified, a SOF package should not be subdivided, as the whole relies upon the unique capabilities of each element in the package. This concept of packaging joint SOF capabilities at the tactical level of execution under the control of the supported SOF commander is vital to any understanding of joint SO.

4. Role of USCINCSOC. By law (10 USC 167), USSOCOM is a unified command with certain Service-like functions for all SOF. USCINCSOC normally acts in a supporting role, preparing and providing SOF to theater combatant commanders for employment. USCINCSOC must also be prepared to exercise command of a selected SO mission if directed by the NCA. Should this occur, USCINCSOC will normally respond with an appropriate JSOTF composed of a deployable headquarters and operational elements.

5. Role of Theater Combatant Commander. The theater combatant commanders are directly responsible to the NCA for the performance of assigned missions and the preparedness of their commands. They exercise Combatant Command (command authority) (COCOM) over assigned forces, including SOF. They synchronize the action of air, land, sea, space, and SO forces within their assigned areas of responsibility (AORs) to achieve strategic and operational objectives through integrated, joint campaigns and major operations. Theater combatant commanders organize and employ their forces as they consider necessary to perform assigned missions.

6. Role of Theater COMSOC. Each theater combatant commander has established a theater subordinate unified special operations command (SOC). When SOF are assigned or attached to a theater combatant commander, COMSOC normally exercises operational control (OPCON) of those forces for joint SO. In this capacity, the COMSOC serves as the theater functional component commander for SO, or JFSOCC (see Chapter III, Joint Pub 3-05). The JFSOCC is normally responsible to the theater combatant commander for the planning and conduct of all joint SO in the theater. However, the theater combatant commander may direct the JFSOCC to transfer OPCON or tactical control (TACON) of SOF to another subordinate component commander when those SOF directly support that component commander's operations.

7. Role of Theater Service Component Commander. Unless otherwise directed by the theater combatant commander, the theater Service component commanders exercise administrative control (ADCON) of assigned and attached Service SOF and are responsible for Service-specific administration and support of these forces. Service component commanders also exercise OPCON of specific assigned and attached SOF as directed by the theater combatant commander to plan and conduct uni-Service SO; such operations are beyond the scope of this publication. The COMSOC monitors Service component activities to ensure adequate support of theater SOF and to guard against unintentional piecemealing of SO capabilities and fragmenting lines of command.

a. When a theater Service component commander cannot satisfy Service SOF sustainment requirements, the theater combatant commander may direct another Service component commander to provide this support.

b. When the COMSOC determines that standard Service logistic systems are unresponsive or inadequate, the Services, in coordination with the theater combatant command and theater Service component commands, are responsible for ensuring that effective and responsible SOF support systems are established.

Faint, illegible text at the top of the page, possibly bleed-through from the reverse side.

Second block of faint, illegible text.

**(INTENTIONALLY BLANK)**

Third block of faint, illegible text.

## CHAPTER II

## MISSIONS AND CAPABILITIES

1. General. This chapter discusses SO missions and SOF capabilities from the perspective of the JFSOCC. SOF possess a combination of highly refined and focused conventional warfighting skills, as well as unconventional capabilities that are qualitatively different from the capabilities of conventional military forces. The JFSOCC matches SOF capabilities to mission requirements. For example, the infiltration of a SOF element by MC-130 aircraft permits operation in hostile environments beyond the capabilities of standard tactical airlift. Although the basic skills for the infiltration are the same, the requirement to airdrop personnel and equipment at an unmarked drop zone, undetected by hostile air defense, at night and under adverse weather conditions, are SO unique and require specialized skills and equipment beyond those required for conventional airdrop. Joint Pub 3-05 contains further discussion of SO missions and SOF capabilities.

2. Unconventional Warfare. UW includes guerrilla warfare, subversion, sabotage, intelligence activities, evasion and escape, and other activities of a low visibility, covert or clandestine nature.

a. UW may occur within the context of conflict or war. When UW is conducted independently during conflict or war, its primary focus is on political and psychological objectives. A successful effort to organize and mobilize a segment of the civil population may culminate in military action. When UW operations support conventional military operations, the focus shifts to primarily military objectives. However, the political and psychological implications remain.

b. Generic capabilities required for UW include an understanding of UW theory and insurgent tactics, language proficiency, area and cultural orientation, tactical skills (through brigade level), advanced medical skills, rudimentary construction and engineering skills, familiarity with a wide variety of demolitions and weapons, and knowledge of clandestine communications, intelligence systems, civil-military operations, and PSYOP. SOF units possess differing combinations of these capabilities. When tailoring forces for UW, the JFSOCC matches unit capabilities to mission-specific requirements, often resulting in a joint tactical element.

(1) ARSOF. UW is principally the responsibility of Army special forces (SF). SF operational detachments



possess all required UW skills in a single tactical unit. CA FID/UW battalions and PSYOP units frequently augment SF for UW operations. ARSOA units perform special air operations in support of SOF conducting UW operations. Rangers are not trained for UW.

(2) NAVSOF. Navy SEALs are the primary NAVSOF trained and equipped to conduct UW in littoral and riverine environments. These environments require exceptional fitness and advanced swimming, combat diving, and boating skills. Special boat units provide combatant craft in support of UW operations. Although SEAL delivery vehicle personnel are qualified SEALs who possess inherent skills to perform UW missions, they specialize in operating SDVs and would most likely provide infiltration and exfiltration support. Forward-based NSWUs provide planning, logistic, and administrative support for UW. Depending upon theater requirements, NSWGs may tailor forces to conduct UW, or NAVSOF may be integrated into a joint package as the maritime extension of a predominantly land-oriented UW mission.

(3) AFSOF. AFSOF aircraft support UW by conducting special air operations to provide covert, clandestine, or low-visibility infiltration, exfiltration, resupply, surveillance, and fire support for other SOF elements. AFSOF may also conduct UW by training, advising, and assisting the air forces of an insurgent or resistance organization or a third-country sponsor to conduct special air operations similar to those conducted by US AFSOF. AFSOF special tactics teams possess skills that are frequently required within a joint UW package. AFSOF airborne PSYOP dissemination assets may be employed as force multipliers for military actions, electronic combat measures, or support of tactical cover and deception activities.

3. Direct Action. DA operations are short-duration strikes and other small-scale offensive operations principally taken by SOF to seize, destroy, capture, recover, or inflict damage on designated personnel or materiel.

a. Unlike UW, DA operations are normally limited in scope and duration and usually incorporate a planned withdrawal from the immediate objective area. SOF may conduct these operations unilaterally or in conjunction with conventional military operations. DA operations are designed to achieve specific, well-defined, and often time-sensitive results. They frequently occur beyond the

reach of tactical weapon systems and selective strike capabilities of conventional forces.

b. Generic capabilities required for DA include small unit combat skills, specialized weapons and demolition expertise, proficiency in specialized infiltration and exfiltration techniques, and a greater degree of physical stamina than normally required of general purpose forces. SOF conducting DA have limited capability for sustained combat and provide limited combat power (the largest SOF DA element is a Ranger Regiment). Although most SOF have some degree of DA capability, JFSOCC must determine which units are best suited for individual missions. Because DA missions depend heavily upon unit cohesion, the JFSOCC should maintain unit integrity for each mission subtask. For example, if a mission includes an airfield seizure among other tasks, the JFSOCC should assign the seizure to a single SOF unit (Rangers are specifically trained to do this). The other tasks should be assigned to other integral SOF units.

(1) ARSOF. ARSOF trained to conduct DA include Rangers, SF, and SOA. Rangers normally employ battalion-sized task forces that include PSYOP and CA elements. SF operate in detachment or company strength for DA missions. Army SOA possesses limited unilateral DA capabilities (guns, rockets, and missiles) but normally supports a SOF ground force.

(2) NAVSOF. NAVSOF trained to conduct DA include SEALs, SDVs, and SBUs. SEALs operate in platoons or squads (16- or 8-man elements), SDVs in platoons, and SBUs in two-boat detachments (usually in support of SEALs).

(3) AFSOF. Under most circumstances, AFSOF are integral to a joint SOF package for DA missions. Only AC-130 aircraft train extensively for DA fire support. MC-130 COMBAT TALON aircraft train for delivery of gravity-employed munitions. MH-53J PAVE LOW and MH-60 PAVE HAWK helicopters, primarily armed for self-defense, can provide limited fire support to SOF ground elements. Special tactics teams routinely provide their unique capabilities to joint DA forces. AFSOF airborne PSYOP dissemination assets may be employed as force multipliers for military actions, electronic combat measures, or support of tactical cover and deception activities.

4. Special Reconnaissance. SOF conduct a wide variety of information-gathering activities of strategic or operational significance. Collectively, these activities are called SR.

SR complements national and theater intelligence collection systems by obtaining specific, well-defined, and time-sensitive information when other systems are constrained by weather, terrain-masking, hostile countermeasures, or conflicting priorities.

a. The JFSOCC receives SR taskings from the theater combatant commander, identifies collection requirements that support joint SO and validates SR missions requested by other component commanders. These responsibilities require routine JFSOCC participation in all theater-level targeting and planning activities.

b. SR varies widely from mission to mission; there is no set of generic collection capabilities. SR missions are distinct from other types of reconnaissance in that they require the unique skills of SOF. The JFSOCC must analyze each mission to determine the skills required and choose the appropriate SOF tactical elements. Virtually all SOF may be used for some aspect of SR. Unlike DA, unit integrity for SR may be disrupted if the unique capabilities of a few additional individuals are required. Augmentees must have a complementary skill set and rehearse critical parts of the mission with the SR team to which they are attached.

(1) ARSOF. SF is the only ARSOF specifically trained to perform SR. They possess limited SIGINT and chemical reconnaissance assets that complement the SR mission. To adequately prepare for unique theater SR requirements, SF must conduct training based upon clearly articulated JFSOCC requirements. Army SOA can perform limited SR missions visually and with their sensors. PSYOP and CA augmentation is particularly useful for area assessment missions.

(2) NAVSOF. SEALs and SDVs are specifically trained to conduct SR. Special boat units have limited inherent capabilities to perform SR but can provide a maritime platform for intelligence collection.

(3) AFSOF. AC-130 gunships can perform SR missions with their FLIR sensors, radar, and low light and infrared imaging and have imagery recording capability. MC-130 Combat Talons have FLIR sensors and imagery recording capability. Special tactics teams can perform SR and possess unique airfield assessment capabilities. AFSOF airborne PSYOP assets may be employed to monitor and record electronic communications information.

5. Foreign Internal Defense. FID is participation by civilian and military agencies of a government in any of the action programs taken by another government to free and protect its society from subversion, lawlessness, and insurgency. Therefore, FID is an umbrella concept that covers a broad range of activities, always with the primary intent of helping the legitimate host government address internal threats and their underlying causes. Because US forces will not normally be committed to combat against foreign insurgents, FID will usually consist of indirect assistance, participation in combined exercises and training programs, or limited direct assistance without US participation in combat operations.

a. FID activities are normally conducted during peace or conflict, usually under DOS control, but they may also occur during war. The COMSOC is responsible to the theater combatant commander for the overall planning and supervision of all SO FID missions within the theater, including those conducted under the OPCON of an SAO chief or another JFC. The COMSOC must coordinate with USSOCOM for preparation of CONUS-based SOF and must monitor SOF deployment, employment, sustainment, and redeployment.

b. Joint Pub 0-2 requires all Services to prepare forces for the conduct of FID, but only SOF routinely train for FID as a primary mission. The role of SOF in FID is to train, advise, and assist host-nation military and paramilitary forces in their conduct of internal defense and development. SOF do not normally command host-nation forces. Because SOF focus on developing indigenous leaders, organizations, and individual skills, they conduct FID operations primarily on a personal level rather than through transfer of hardware. The SAO chief or other responsible JFC must synchronize the training and advisory activities of SOF with the material and technical assistance available from other sources as part of an integrated US Government effort.

c. Generic capabilities required for FID include instructional skills; foreign language proficiency; area and cultural orientation; tactical skills; advanced medical skills; rudimentary construction and engineering skills; familiarity with a wide variety of demolitions, weapons, weapon systems, and communications equipment; and basic PSYOP and CA skills. Great flexibility is available to the JFSOCC in tailoring SOF for FID. FID-related capabilities are spread throughout SOF, conventional forces, and other government agencies. Forces that do not regularly train to conduct FID participate as required to meet specific needs.

(1) ARSOF. SF, CA, and PSYOP forces are area oriented, language qualified, and specifically trained to develop HN capabilities that will sustain themselves after the departure of US forces. ARSOA and Rangers are not trained, organized, or equipped for the conduct of FID. A large portion of PSYOP and CA force structure is maintained in the Reserve component. These forces must be notified much earlier than Active components, unless mobilization occurs. Individual reservist augmentation (one or two people) to FID packages is easier and quicker to arrange than unit deployments.

(2) NAVSOF. SEALs and SBUs are specifically trained to conduct FID. As with UW, forward-based NSWUs provide planning, logistic, and administrative support for FID. Depending upon theater requirements, NSWGs and Special Boat Squadrons (SBRs) will tailor forces to conduct FID. NAVSOF may be integrated into a joint SOF FID package in a littoral nation or a landlocked nation with an extensive riverine environment.

(3) AFSOF. AFSOF are best qualified for FID when the JFSOCC requires aviation employment or support skills and experience. In particular, USSOCOM is developing an aviation cadre that is culturally and linguistically trained and oriented toward developing nations. The aviation cadre is skilled in the use of aerospace power for UW, counterinsurgency, and counterdrug operations. Their skills make them well suited for use in coalition warfare or in support of a theater commander's peacetime campaign plan. Special tactics teams can provide basic ground-to-air interface and combat casualty training with AFSOF or HN aircraft. AFSOF are prepared to assess HN aviation needs and provide the JFSOCC with other aviation FID assistance. The JFSOCC can optimize AFSOF FID potential by forwarding theater requirements to USCINCSOC. AFSOF assets should not be used to provide administrative airlift in support of FID operations.

6. Counterterrorism. CT is a highly specialized, resource-intensive mission. Certain SOF units maintain a high state of readiness to conduct CT operations and possess a full range of CT capabilities. Theater combatant commanders maintain designated CT contingency forces to respond to CT situations when national assets are not immediately available. When SOF comprise these forces, the JFSOCC is responsible for their readiness.

7. Collateral Activities. Collateral activities are applications of SOF capabilities in other than primary mission areas. The collateral activities for which SOF are particularly well suited include security assistance, humanitarian assistance, antiterrorism and other security activities, counterdrug operations, personnel recovery, and special activities. (Joint Pub 3-05 contains further discussion of collateral activities.) The JFSOCC assists the theater combatant commander in identifying collateral activities that capitalize on the inherent capabilities of SOF within the constraints of their availability. In any theater, the number of possible collateral activities is unlimited. The JFSOCC should discourage the use of SOF for collateral activities when conventional forces are available and capable of performing the mission to standard. When tasked, SOF analyze the situation, adapt to it, and apply their capabilities as appropriate. The responsibilities of the JFSOCC for SOF conducting collateral activities are the same as for SOF conducting primary missions.

8. Operational Mission Taskings. Theater-specific mission taskings may be beyond the scope of primary SO missions. Such taskings affect the training of forces apportioned to that theater but will not affect SOF worldwide (as would a change in doctrine). The JFSOCC must clearly communicate theater-specific requirements so that USCINCSOC can prepare forces to meet the needs of the theater combatant commander. An example of such an operational mission tasking was the SF coalition warfare mission during Operations DESERT SHIELD and DESERT STORM. In this case, the Commander in Chief of US Central Command (USCINCCENT) identified the requirement for providing liaison and training and advisory assistance to maintain cohesion among the coalition partners. As the JFSOCC, the commander of the Special Operations Command, Central (COMSOCCENT) advised USCINCCENT that SOF capabilities required to conduct FID and UW would be applicable to this requirement. As a result, SF were tasked and performed the operational mission under the OPCON of Third US Army. After the operation, the SF soldiers involved reported that the rapport-building skills developed during UW training exercises were critical during their initial contacts.

9. Operational Training. During peace, the distinction between primary missions, collateral activities, and training (especially OCONUS training) is often blurred. The division becomes more distinct during contingency operations and war, when these activities tend to compete for assets.

a. Peacetime Activities. In peacetime, SOF training events often contribute directly to theater operational objectives. For example, FID-related training in a foreign country may produce benefits to the HN that

contribute to the theater combatant commander's peacetime campaign objectives. This is consistent with the primary mission of FID. Performing collateral training and advisory activities under a security assistance program, for example, provides excellent training to SOF in skills critical to their primary missions. The JFSOCC, in coordination with USCINCSOC, advises the theater combatant commander on how best to orchestrate SO activities so that SOF training events contribute to achieving peacetime campaign objectives.

b. Contingency Operations and War. During contingency operations and war, SOF units focus their training on actual rather than anticipated mission requirements. Collateral activities detract from the overall capability of SOF to perform their primary SO missions. The JFSOCC must ensure that the theater combatant commander is aware of the impact of diverting SOF from primary missions to collateral activities under these circumstances.

10. Conventional Applications of SOF. SOF should not be used as a substitute for strong conventional forces. This degrades the ability to conduct SO and places at great risk specialized assets that are not easily replaced. SOF can enhance conventional operations as a force multiplier or in an economy of force role that does not involve using SOF in conventional roles. Although some SOF have limited capabilities for use as conventional forces when absolutely necessary, this application takes the forces out of the framework within which they routinely operate. They are subsequently unable to respond to legitimate SO tasking and may be placed at risk through employment outside the supervision or control of the JFSOCC. The JFSOCC ensures that the theater combatant commander understands the tradeoffs involved and makes optimum use of SOF assets within his theater.

11. Other Forces Trained and Equipped to Support SO. Certain general purpose forces receive enhanced training and specialized equipment that make them uniquely qualified to support SO. This special training and equipment are not provided to enable these forces to conduct SO as a primary mission but to improve their own primary combat skills and capabilities. See Appendix K for more detail on these forces.

## CHAPTER III

## COMMAND AND CONTROL OF SPECIAL OPERATIONS

1. General. SO require centralized, responsive, and unambiguous C2. Unnecessary layering of headquarters within the SO chain of command decreases responsiveness and creates opportunities for OPSEC compromises. The normal C2 arrangement for joint SO is to establish a functional SO component under the direct OPCON of the joint force commander.
2. The Theater Special Operations Command. To provide the necessary unity of command, each theater combatant commander has established a subordinate unified command to serve as the functional SO component of the theater combatant command (see Figure III-1). These commands, the theater SOCs, normally exercise OPCON of joint SOF within their theaters. USSOCOM provides some of the funding and manpower to support the theater SOCs, similar to the Service support of theater Service component headquarters. The COMSOC is the theater JFSOCC, reporting directly to the theater combatant commander, and is the principal SO adviser in theater. These two roles are discussed below.
  - a. SO Adviser. The COMSOC advises the theater combatant commander and the other component commanders on the proper employment of SOF. As SO adviser, COMSOC must be familiar with the day-to-day issues working within the theater combatant command. The COMSOC may be dual-hatted as a special staff officer on the theater staff. In this case, he may appoint a deputy to represent him on the theater staff for routine day-to-day staff matters.
  - b. Theater JFSOCC. COMSOC exercises OPCON of assigned forces and normally exercises OPCON of attached forces. He uses some combination of Service, functional and area components. He establishes subordinate headquarters as required (see Figure III-2) to plan, conduct, and support joint SO on a continuing basis. The following paragraphs discuss the options available to the JFSOCC.
3. Army SOF. The JFSOCC may exercise OPCON of ARSOF through a single ARSOC or multiple ARSOTFs.
  - a. Army Special Operations Component. A single ARSOC is most appropriate when there is only one SF or Ranger unit OPCON to the JFSOCC.
  - b. Army Special Operations Task Force. When two or more of these units are OPCON to the JFSOCC, the JFSOCC normally establishes a number of subordinate ARSOTFs.



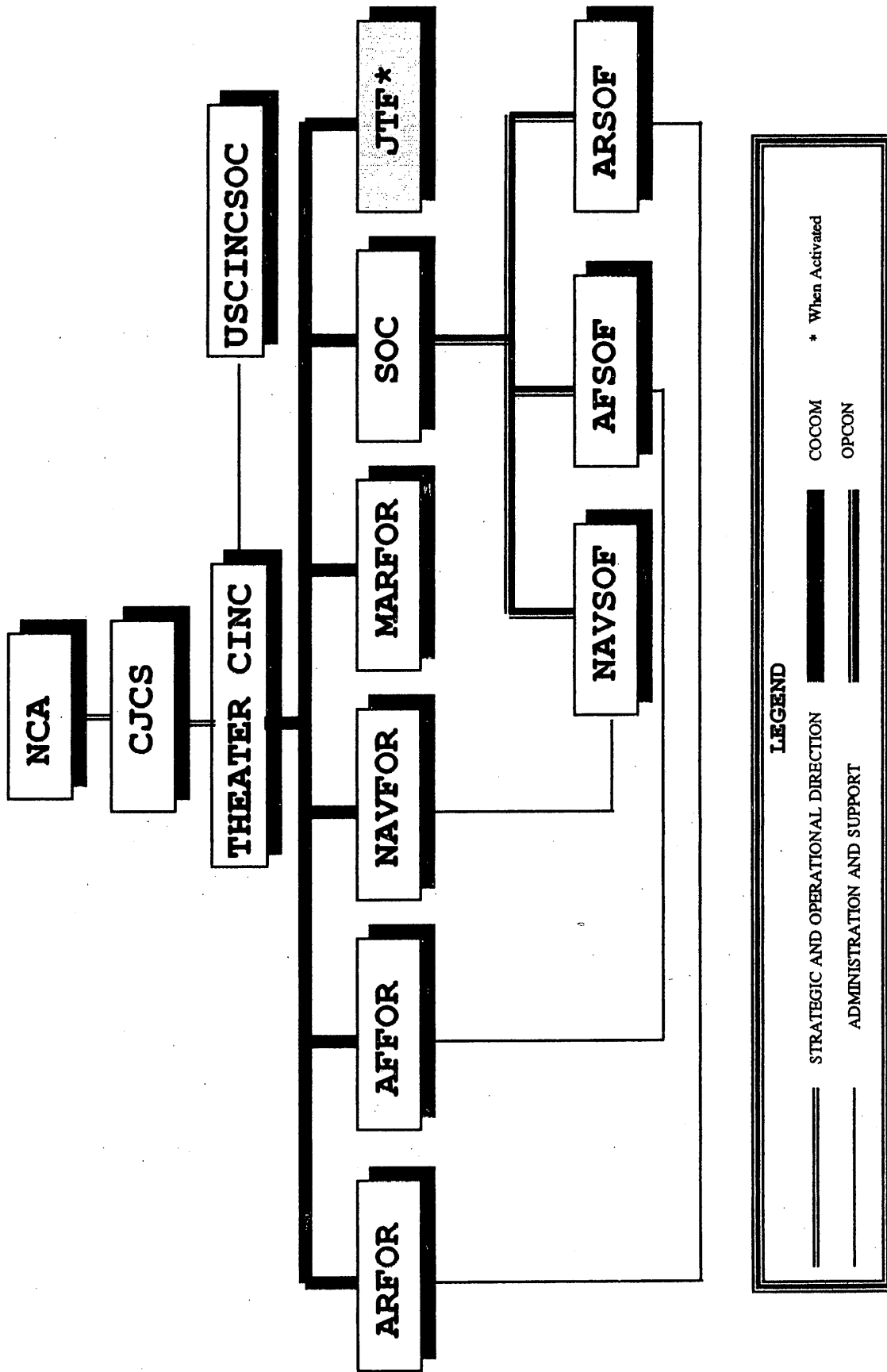

Figure III-1. Notional Theater Organization

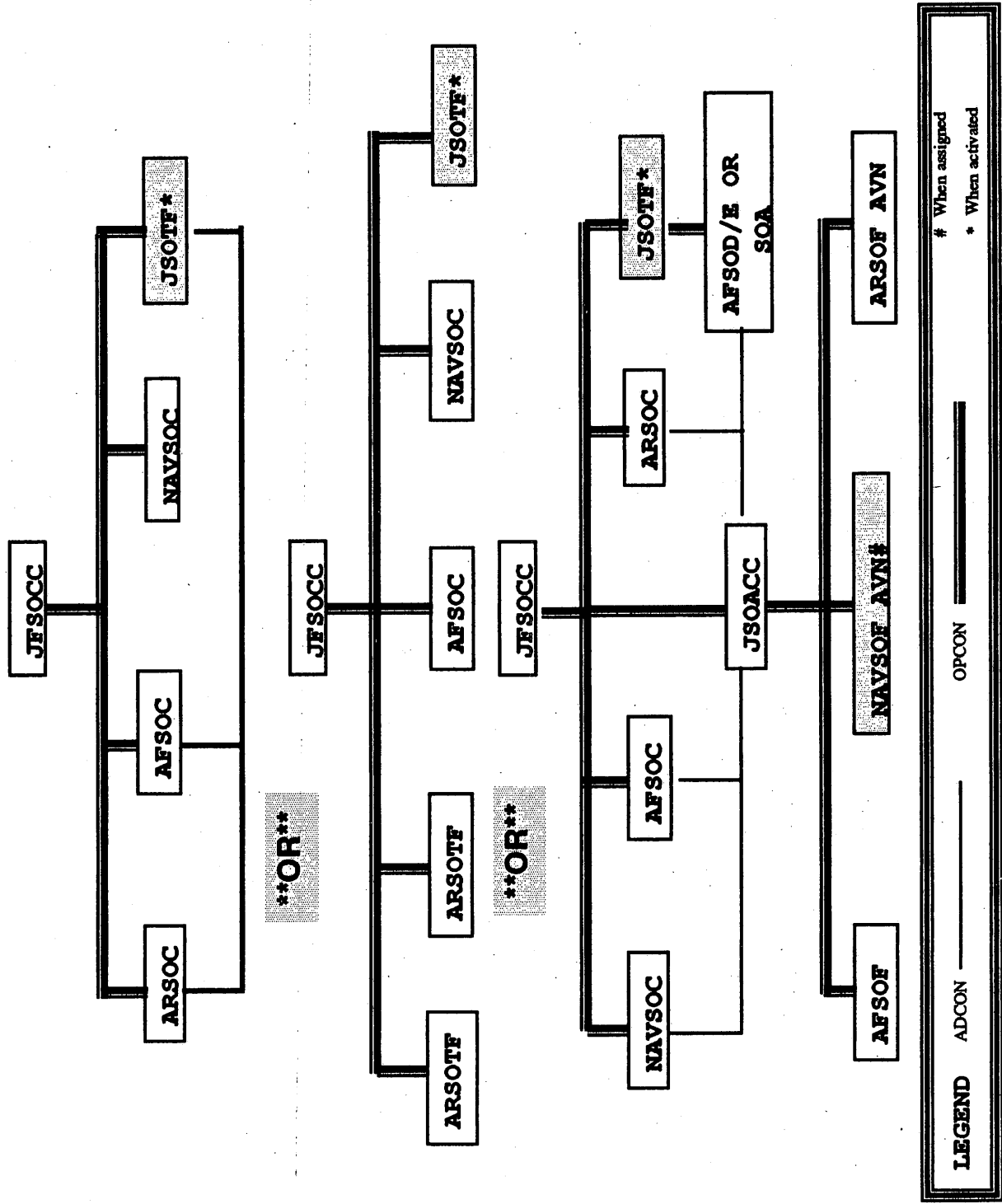

Figure III-2. Notional JFSOCC Command Relationships

Each ARSOTF is organized around the nucleus of an SF or ranger unit and includes a mix of ARSOF units and their support elements. The JFSOCC assigns each ARSOTF a geographic area or functional mission under his direct OPCON.

c. Special Forces. SF units normally task organize into a number of operations bases. Used in this sense, the term "operations base" connotes a headquarters and support element as well as a physical location. SF operations bases include the SFOB, the FOB, and the AOB.

(1) Special Forces Operations Base. The SFOB is established by an SF group to synchronize the activities of subordinate FOBs and/or AOBs. The SFOB normally serves as an ARSOC or ARSOTF headquarters directly subordinate to the JFSOCC.

(2) Forward Operations Base. An FOB is established by an SF battalion to control and support deployed operational elements. Tactical SF elements conduct mission planning and preparation at an FOB. Although generally subordinate to an SFOB, an independent FOB may be established under the direct OPCON of the JFSOCC.

(3) Advanced operations Base. An AOB is established by an SF company to extend the command, control, and support functions of an FOB. For example, an AOB may function as a launch-and-recovery or radio relay site.

d. Rangers. Rangers normally exercise C2 through command posts collocated with other SOF or conventional units. They do not have the organic capability to establish their own operations bases.

e. Army Special Operations Aviation. ARSOA normally exercise C2 through task force headquarters collocated with the JSOACC (see below) or a supported ARSOTF or NSWTG.

4. Navy SOF. The Navy component of the theater JFSOCC is referred to as the Navy Special Operations Component. A NAVSOC may take the following forms:

a. Naval Special Warfare Unit. An NSWU is the permanent in-theater operational staff to command, control, and support forward-deployed CONUS-based NSW forces. The NSWU can easily form the nucleus for a NSWTG or NSWU.

- b. Naval Special Warfare Task Group. When activated, an NSWTG is specifically tailored to meet the requirements of the theater combatant commander. An NSWTG is a headquarters that provides C3 for any number of deployed NSWTUs in support of fleet commanders and joint force commanders.
  - c. Naval Special Warfare Task Unit. An NSWTU is a subordinate headquarters element of the NSWTG that provides C3 to employed NSW forces.
  - d. Naval Special Warfare Task Element. An NSWTE is a subordinate element of an NSWTU.
5. Air Force SOF. The Air Force component of the theater JFSOCC is referred to as the Air Force Special Operations Component (AFSOC). (The theater AFSOC should not be confused with the Air Force Special Operations Command, the Air Force component command of USSOCOM.) The theater AFSOC is normally a special operations wing (SOW) or special operations group (SOG). When subordinate AFSOF units deploy to FOBs or AOBs, the AFSOC commander may establish one or more of the following provisional units:
- a. Air Force Special Operations Detachment. The AFSOD is a squadron-size AFSOF headquarters, which could be a composite organization composed of different Air Force SO assets. The detachment is normally subordinate to a theater AFSOC, JSOTF, or JTF, depending upon size and duration of the operation.
  - b. Air Force Special Operations Element. The AFSOE is an element-size AFSOF headquarters. It is normally subordinate to a theater AFSOC or AFSOD, depending upon the size and duration of the operation.
6. Joint Special Operations Air Component. The JFSOCC may choose to organize functional components in lieu of or in combination with Service components. The most common SO functional organization is the JSOAC. The JSOACC is the subordinate commander within a SOC or JSOTF responsible for planning and executing joint special air operations and for coordinating and deconflicting those operations with conventional air operations. The JSOACC normally will be the SOF aviation commander providing the preponderance of air assets or most capable of controlling special air operations in a specific situation.
7. Joint Special Operations Task Force. A JSOTF is a temporary joint SOF headquarters established by the NCA or a JFC to accomplish a specific mission or control SOF in a specific theater of operations. Establishment of a JSOTF is

appropriate when SOF C2 requirements exceed the capabilities of the theater SOC.

a. Organization. The term JSOTF is generic and does not apply to any specific organization, unit, or level of command. JSOTFs may be small and temporary or larger and more permanent, depending upon the national or theater objective. A JSOTF may be specifically established as a joint organization, or it may be formed around an existing Service force structure with an augmented staff. It may consist of elements of the theater SOC (with or without USSOCOM augmentation) or deploy as a complete package from outside of the theater at the direction of the NCA.

b. Command Arrangements. Although options are unlimited, a JSOTF is normally subordinate to the theater SOC or another JFC to perform missions of limited scope or duration. When subordinate to a JFC other than the theater SOC, the JSOTF commander serves as the JFSOCC for that JFC.

c. Area versus Functional Command. A JSOTF can be either an area or functional component. A JSOTF could be established to conduct joint SO in a specific theater of operations. Alternatively, it could be established to accomplish certain types of SO. For example, the COMSOC may designate an NSWTG as the nucleus of a JSOTF headquarters to conduct a series of related DA missions. Assigned forces may include a NSWTU, a Ranger battalion, and a helicopter and tanker AFSOD. The NSWTG would require ARSOF and AFSOF augmentation to function effectively as a JSOTF.

8. Transfer of Forces. Only the NCA can authorize and direct the assignment of forces to combatant commands or their transfer between combatant commands. When transfer of forces is permanent, the forces are reassigned. When transfer of forces is temporary, the forces may be either reassigned or attached. If the forces are reassigned, the gaining combatant commander exercises COCOM of the reassigned force. If the forces are attached, the NCA normally specifies in the deployment order that the gaining combatant commander will exercise OPCON of the attached force. When USSOCOM forces deploy from CONUS into a theater for a specific short-duration mission, these forces are normally attached to the theater combatant commander and may be placed OPCON to the JFSOCC. This requires extensive coordination when the mission is planned out of theater. Because USSOCOM must prepare the forces, it is vital that the JFSOCC clearly communicate the theater combatant commander's requirements. The JFSOCC assists the theater combatant commander in CHOP of

SOF from USSOCOM to theater control, coordinating transfer to the theater C4I structure and arranging in-theater support, to include necessary staging facilities. This may require coordination with other theater combatant commanders when those facilities lie within their AORs. Virtually all operations transiting non-US territory will require interagency coordination, especially with the DOS and appropriate in-country Chiefs of Mission. The JFSOCC should ensure, via the theater combatant commander, that necessary clearances are obtained from those nations whose sovereign interests are involved. JFSOCC planning must ultimately include force recovery and redeployment.

9. SO and Air Operations. SO aircraft normally traverse multiple zones of airspace control and may overfly conventional surface operations while inserting, resupplying, or extracting SOF elements. Because joint air forces and SOF routinely operate in the deep battle area, their operations must be fully integrated to create opportunities for synergistic attack and deconflicted to prevent fratricide.

a. Conventional Air Support to SO. Commanders may employ virtually any aerospace forces in SO, and SOF may require support from conventional assets to suppress enemy air defenses, cause diversions, increase airlift capability or ensure the air and ground defense security of their landing strips or forward arming and refueling points. These augmenting forces provide capabilities beyond those found in SO aviation forces. The JFSOCC normally requests conventional air support sorties to support SOF on a mission-by-mission and priority availability basis, but the JFC may direct a transfer of control to the JSOACC or COMAFSOC for a specified and usually short period of time. Regardless of command relationships, integrating non-SOA assets into special air operations requires advance planning and extensive coordination.

b. SOF Support of Joint Air Operations. SOF can contribute to joint air operations in four ways:

(1) Economy of Force. In most threat environments, SOF can provide stealth and precision attack as an alternative to air power. The JFACC can therefore request the use of SOF as an economy of force measure to destroy certain targets, freeing air assets to concentrate against other targets more suitable for air attack. For example, SOF attacked Iraqi early warning sites in the initial phase of Operation DESERT STORM, allowing the JFACC to employ the entire F-117 force to strike Baghdad.

(2) Precision Attack. The JFACC may have targets that require specific damage effects (or the limitation of collateral damage) beyond the capabilities of precision-guided munitions. Some examples include the destruction or incapacitation of weapons of mass destruction or their production facilities without the spread of deadly contaminants. The JFC may want to neutralize a target without destroying its vital components. SOF may also be employed to locate and attack concealed, perishable, or mobile targets that are difficult for conventional air and surface forces to attack.

(3) Synergistic Attack. SOF can contribute directly to joint air operations by conducting asymmetrical DA strikes against airfields, ground radars, and other high-value counterair targets. SOF can also locate and identify mobile targets and then designate them visually, electronically, or optically for conventional air attack. SOF can also perform poststrike reconnaissance missions after conventional air strikes.

(4) Air Operations Enhancement. SOF have unique capabilities that can enhance joint air operations. For example, SOF aircraft can deliver the 15,000-pound BLU-82 bomb for psychological effect or to create an instant helicopter landing zone. SOF can also conduct certain personnel recovery missions beyond the capabilities of conventional CSAR forces.

c. Special Operations Liaison Element. The JFSOCC provides a special operations liaison element (SOLE) to the JFACC staff (if designated) or appropriate Service component air C2 facility to coordinate and synchronize SOF air and surface efforts with joint air operations. The SOLE chief works directly for the JFSOCC and places liaison officers throughout the JFACC or (Service component air) staff. Under the direction of the SOLE chief, these liaison officers provide SOF expertise to the following elements of the JFACC (or Service) staff:

(1) Air Operations Planning Cell. SOF coordination with the air operations planning cell is vital. In peacetime, this cell develops the air operations plan and publishes a preplanned air tasking order (ATO) to execute it. During hostilities, the cell becomes the central air targeting facility and deconflicts targets. The JFSOCC can influence air tasking of SOF in support of theater air operations and deconflict SO through the SOF air planners in this cell.

(2) Combat Plans. SOF air planners in this directorate develop, coordinate, and submit SOF tasks for the next day's operations into the single theater ATO. They identify every SOF air mission in the ATO; coordinate assignment of aircraft IFF squawks and call signs; deconflict airspace; place JSOAs, RFAs, and NFAs into the Airspace Coordination Order; request conventional air support of SOF; and relay requests for SOF support to the JFSOCC.

(3) Combat Operations. SOF air operations officers in this directorate monitor ongoing air missions and make crisis management decisions. These SOF air operations officers perform similar functions to those performed by the SOF air planners in Combat Plans for SOF aircraft operating during the current ATO cycle, to include one that is closed for publication. They monitor all air mission activity, report events affecting SO to the JFSOCC, and track the progress of JFSOCC air support requests.

(4) Joint Rescue Center (JRC). SOF LNOs to the JRC advise its director on SOF availability and requirements and facilitate coordination with the JFSOCC RCC.

10. SO and Land Operations. SOF frequently operate in conjunction with conventional military forces conducting land operations. Physical contact between conventional land forces and SOF is typically of short duration. It usually ends with a passing of responsibility and or the extraction of SOF. Therefore, the focus of coordination should be on synchronization of effects and deconfliction of fires, not on physical integration of forces on the ground. Synchronization is the arrangement of military actions in time, space, and purpose to produce maximum relative combat power at a decisive place and time. Physical integration may occur, but it is not necessary in all cases to achieve a synergistic effect. The focal point for the synchronization of SO activities with land operations is the special operations command and control element (SOCCE).

a. The SOCCE is a C2 element normally task-organized around an SF company headquarters. It performs C2 or liaison functions according to mission requirements and as directed by the JFSOCC. The SOCCE is normally employed when SOF (not exclusively ARSOF) conduct operations in support of a conventional joint or Service force (for example, a joint task force, Army corps or Marine expeditionary force). It collocates with the command post of the supported force to coordinate and deconflict SO with the operations of the supported force



and ensure communications interoperability with that force. The ARSOTF commander and other JFSOCC component commanders may attach liaison teams from other SOF elements to the SOCCE as required. The SOCCE performs the following functions:

- (1) Exercise C2 of SOF tactical elements attached to, or placed in direct support of, the supported conventional land force.
- (2) Augment or serve as the SO special staff section of the land force headquarters.
- (3) Advise the land force commander on the current situation, missions, capabilities, and limitations of supporting and supported SOF units.
- (4) Advise the supporting SOF commander(s) of the land force commander's current situation, missions, intentions, and requirements.
- (5) Provide required secure communications links.
- (6) Coordinate and deconflict SO activities with land force operations, including SOF support to the land force and land force support to SOF.
- (7) When linkup becomes imminent, assist land force with linkup planning and execution.

b. The SOCCE's level of authority and responsibility can vary widely. When directed, the SOCCE can control SOF operational elements for short periods during specific missions (for example, linkup operations). It can also receive SOF operational, intelligence, and target acquisition reports directly from deployed SOF elements and provide them to the land force headquarters. See FM 100-25 for further discussion of the SOCCE.

11. SO and Maritime Operations. SOF also frequently operate in conjunction with conventional maritime forces. Physical contact between conventional maritime forces and SOF is likely to be of longer duration than is normally the case for land operations, and the focus of coordination must be on physical integration of forces as well as synchronization of effects and deconfliction of fires. Coordination with the maritime force staff is performed by a SOCCE, an NSW liaison element or a collocated NSWTU staff.

a. When physical integration is minimal and the primary concern of the JFSOCC is coordination of SOF maritime maneuver and deconfliction of naval fires, the JFSOCC

normally places a SOCCE or NSW liaison element with the JFMCC staff and the staffs of appropriate maritime task forces or battle groups. Other JFSOCC component commanders may attach liaison teams to the SOCCE or NSW liaison element as required. The element performs functions similar to those listed above for the SOCCE.

b. When there is a requirement to exercise C2 of NSW operational elements as well as perform liaison functions, the JFSOCC normally places an NSWTU (ashore or afloat) under the OPCON or TACON of the appropriate maritime force commander. If joint SOF are committed to supporting maritime operations, the JFSOCC may augment the NSWTU staff and establish it as a subordinate JSOTF.

normally placed a SOCC of NSW liaison element with the  
TWCC staff and the staff of supporting/controlling units  
forces of police units. Other SOCC component  
commanders may attend liaison force on the SOCC of NSW  
liaison element. The element commander  
liaison element is listed above for the SOCC.

d. When there is a requirement to provide a liaison  
operational element as well as liaison force  
functional, the TWCC normally places the NSWTWCC liaison  
element under the command of TACOM of the appropriate  
liaison force commander. If liaison force commander is to  
reporting liaison force, the TWCC may request  
the NSWTWCC staff and liaison force as appropriate.

(INTENTIONALLY BLANK)

## CHAPTER IV

## PLANNING SPECIAL OPERATIONS

1. General. This chapter focuses on SO planning from the operational perspective of a theater COMSOC. It provides procedures for the COMSOC's participation in theater-level planning and the supervision of tactical planning by subordinate SOF elements. It does not address detailed tactical mission planning (ground maneuver plan, infiltration route planning, etc.) because this activity is governed by Service guidance and unit SOPs.

2. Maintenance of Theater Perspective. The COMSOC, as the theater JFSOCC, must maintain a long-term theater planning perspective. Deliberate and peacetime planning may continue during a crisis or regional contingency. In a minor crisis or contingency operation, the COMSOC may continue to function at the theater level. In this case he normally establishes a JSOTF to serve as the JFSOCC for the current operation. In a major contingency operation or during sustained combat operations, the COMSOC normally deploys as the JFSOCC. In this case, he must divide the SOC staff so that SO outside the area of conflict and long-term planning may continue.

3. Deliberate Planning. Deliberate planning is planning for the deployment and employment of apportioned forces and resources that occurs in response to a hypothetical situation. Planners rely heavily on assumptions regarding the circumstances that will exist when the plan is implemented. The COMSOC actively participates in all phases of theater-level deliberate planning, both as a component commander and principal theater SO adviser. Normal deliberate planning responsibilities of the theater SOC include developing OPLANS and CONPLANS (see Joint Pub 5-03.1) and supervising SOMPF production (see Joint Pub 3-05.5). The SOC also participates in theater-level strategy development and campaign planning (see Joint Pub 5-00.1).

a. Concept Development. The COMSOC prepares, or assists in preparation of, the theater SO staff estimate. The COMSOC subsequently attends the concept development conference, which finalizes concepts of operation and support and assigns subordinate tasks. COMSOC participation throughout this phase should ensure that SOF are properly integrated into the theater commander's strategic concept.

b. Plan Development. As the plan develops, the COMSOC assists the theater combatant commander in integrating SO and coordinating with USCINCSOC for CONUS-based support.

(1) Force Planning. The COMSOC assists in preparation of the SO portion of the theater plan and provides the initial SOF force list and TPFDD. Apportioned SOF should deploy as early as possible; the plan may require SOF forward presence during critical time periods when the likelihood of employment is increased. See Appendix P for more information on SOF deployment planning.

(2) Support Planning. The COMSOC coordinates with the theater J4 and theater Service component commanders to determine support requirements for apportioned SOF and how these requirements will be satisfied. SOF normally plan to deploy with their unit basic loads and at least 30 days of accompanying supplies unless otherwise directed by the theater combatant commander. The SO TPFDD input may include dedicated SOF support units.

(3) Transportation Planning, Shortfall Identification, and TPFDD Refinement. If the transportation planning process identifies SOF shortfalls, the COMSOC works with theater planners to resolve the shortfalls. If transportation shortfalls cannot be resolved at the planner level, the COMSOC advises the theater combatant commander and adjusts the plan as directed. As the TPFDD is refined, the COMSOC ensures that SO data is not inadvertently altered.

c. Plan Review and Supporting Plan Development. The COMSOC revises the SO portion of the plan based on the CJCS comments.

4. Supporting Plan Development. Concurrent with the theater deliberate planning process, the COMSOC initiates development of SO supporting plans. Such plans should provide concepts linking SO capabilities to overall theater objectives and complement other theater component supporting plans. The COMSOC develops these plans using a modified version of the deliberate planning procedures outlined in Joint Pub 5-03.1.

a. Mission Analysis and Target Selection. Certain JFSOCC missions may already be specified in a theater plan. In addition to these specified tasks, the COMSOC derives other tasks essential to accomplishing the JFSOCC missions assigned by the theater combatant commander. The COMSOC must consider the window of opportunity (timeframe during which the task makes sense or is feasible) for these tasks. The cumulative effect of these tasks must accomplish the assigned JFSOCC mission and complement other US Government activities within the

theater. Support of conventional military operations is often part of the JFSOCC mission. When specific targets are involved, the Joint Targeting Coordination Board provides the mechanism for validation. For missions without a discrete target (FID, UW), the COMSOC should work closely with the theater J-3 to validate missions.

b. Tactical Force Planning. After defining subordinate missions, the COMSOC must assign those missions to the appropriate SOC component commanders and task them to develop their own supporting plans. The result of this process is a set of SOC component OPLANS that complement each other and describe in detail how each SOC component commander intends to integrate his tactical operations into the overall SOC effort.

c. Targeting and Mission Planning. The COMSOC will normally select a mission planning agent (MPA) to plan and conduct each specific SO mission. The COMSOC normally selects a SOC service component as the MPA but may organize a subordinate JSOTF to be the MPA.

(1) To select the best force, the COMSOC determines the required operational capabilities and then matches them against available unit capabilities. Initially, the COMSOC may identify multiple MPAs to plan the mission in parallel. This option provides flexibility in final force selection but commits additional resources to the planning process.

(2) After selecting the MPA, the COMSOC initiates the joint targeting and mission planning procedures outlined in Joint Pub 3-05.5 to produce a set of SO mission planning folders that describe in detail how SOF intends to execute each predetermined target.

d. Evaluation. The COMSOC uses the approved OPLANS and SOMPFs to develop the theater SO JMETL. The JMETL influences SOC resourcing and drives SOF training.

(1) COMSOC develops theater SO exercise and training programs to meet OPLAN-driven training requirements and to evaluate the adequacy and feasibility of current plans. These programs often serve as deployment mechanisms for SOF conducting operations in support of theater peacetime plans.

(2) USCINCSOC will use theater SOC plans and programs to orient training for forces under his COCOM, develop new SOF capabilities, and determine SO force structure.

(3) COMSOC may also use computerized mission planning aids to evaluate overall risk and run excursions from completed SOMPFs.

5. Time-Sensitive Planning. Time-sensitive planning refers to planning for the deployment and employment of allocated forces and resources that occurs in response to an actual situation. Planners base their products on the actual circumstances that exist at the time planning occurs. As with deliberate planning, the COMSOC actively participates in all phases of theater-level time-sensitive planning.

a. Course of Action Development. The COMSOC prepares, or assists in the preparation of, the SO theater staff estimate and ensures that SOF are properly integrated into the courses of action developed by the theater combatant commander and forwarded to the CJCS and NCA.

b. Execution Planning. The COMSOC initiates execution planning upon receipt by the theater combatant commander of a planning order or alert order that involves the deployment or employment of SOF. SO execution planning normally requires a minimum of 96 hours for basic plan development (or refinement of an existing plan), in-depth wargaming of variations to the basic plan, and preparation of the tactical force to execute the mission. Modern mission planning aids can assist in this process but do not replace human analysis. The time-sensitive SO mission planning process described in Joint Pub 3-05.5 provides a framework to ensure adequate execution planning.

6. Peacetime Planning. Standard joint planning procedures are also used for peacetime planning, but interagency coordination becomes increasingly important. There are no standardized procedures for this coordination. SO planners must be flexible and innovative when integrating peacetime SO with other agencies' activities. Funding sources and procedures may constrain peacetime military operations. The special planning considerations that impact each phase of peacetime planning include:

a. Concept Development. Agencies outside the DOD may not automatically notify the theater combatant commander of their requirements. The COMSOC, therefore, must identify those requirements that specify or imply SO tasks. The COMSOC may accomplish this by reviewing national and theater threat assessments, Ambassadors' annual statements of goals and objectives, Country Team and HN government plans, annual integrated assessments of security assistance, after-action reports and assessments, theater joint mission analysis, civil

affairs unit country surveys, basic PSYOP studies, area studies, and the plans and programs of other US Government agencies (see Appendix F for a list of government agencies routinely involved in peacetime military operations). A generic source of information on an agency's planned activities is their annual budget submission. The SO estimate should include the ability of host nations to absorb US assistance and collateral effects from SOF training activities.

b. Plan Development. Special considerations for SO plan development include:

(1) Force Planning. The COMSOC must identify how all proposed SO activities relate to theater objectives and integrate into the overall US interagency effort. For peacetime military operations, the force planning process begins unresourced. Instead of immediately planning for the flow of apportioned forces into theater, the COMSOC must first identify deployment mechanisms that make forces available for employment. These mechanisms include CJCS and theater exercises, mobile training teams, deployments for training, individual and small unit exchanges, humanitarian assistance activities (10 USC 401 and 402), and military information support teams. Force planning requires the COMSOC to be innovative and recognize opportunities to modify training events so that they also satisfy theater peacetime objectives. For example, in the case of a DFT, the COMSOC starts with an OPLAN training requirement. He then uses scheduled training events that meet the OPLAN training requirement to simultaneously achieve theater peacetime objectives. The COMSOC's operational perspective permits him to get the maximum peacetime effect from OPLAN-derived training. Ultimately, requirements may remain unsatisfied because of a lack of OPLAN or CONPLAN training requirements or force structure. The COMSOC should submit unsatisfied peacetime requirements through the theater combatant commander to USCINCSOC for consideration in force development.

(2) Force Selection. The COMSOC normally selects tactical elements with scheduled OPLAN-based training events to conduct peacetime military operations. For operations without an OPLAN-based deployment mechanism, funding may constrain force selection. The COMSOC must ensure adequate operational planning support, supervision, and guidance for all SO missions conducting peacetime military operations in the theater despite the fact that formal approval



processes may not include the theater SOC. The COMSOC should maintain a close working relationship with theater SAOs to know when to initiate operational planning.

(3) Support Planning. Support of employed SOF in peacetime is constrained by their deployment mechanism. For example, SOF conducting a security assistance MTT must receive all support through security assistance funding. The COMSOC can coordinate that support from any approved source, provided the COMSOC follows the proper procedures for transfer of funds. The COMSOC must not only identify and provide for proper support but must also ensure that employed SOF elements are fully aware of any legal constraints on the disposition of equipment and supplies.

(4) Transportation Planning. Transportation planning will also be constrained by the deployment mechanism. For example, SOF conducting a DFT in theater may coordinate transportation in combination with aircrew flight training. This arrangement would not be acceptable for a security assistance mission that requires the user to pay for transportation.

(5) Shortfall Identification. After examining all available deployment mechanisms and their associated support and transportation options, the COMSOC determines mission shortfalls. The COMSOC then presents the theater combatant commander with options to satisfy unfulfilled requirements. These include requesting additional CJCS exercise funds, additional security assistance funding from Congress, or additional funding from USSOCOM for DFTs.

c. Plan Review and Supporting Plans. Review of plans to employ SOF in peacetime military operations may extend beyond the CJCS. When another US Government agency has the lead, final approval of plans may not reside within military channels. All plans should still proceed through the full military approval cycle before submission to the non-DOD agency with final approval authority. This assists the non-DOD agency by providing the appropriate military expertise for plan review and keeps the theater combatant commander and CJCS informed.

d. Plan Maintenance. Changes in the requirements of non-DOD agencies often impact on peacetime military operations. These agencies may submit their requirements to the theater combatant commander, USCINCSOC, CJCS, or

SecDef. The COMSOC reviews the impact of all emerging SO missions on peacetime military operations.

7. Planning Standards. The following planning standards apply to SOF planning.

a. Format. Use JOPES or USMTF formats for all planning products, depending on whether the product will be disseminated as a document or an electronic message.

b. Time. Use Universal Time, also known as Greenwich Mean Time or ZULU Time.

c. Coordinates. Use Universal Transverse Mercator (UTM) grid coordinates for land operations. Where UTM grid coordinates are not available, fully reference other systems or charts. Use geographic coordinates (latitude and longitude) for operations involving air and maritime forces. Provide both when appropriate.

d. Courses. Reference and annotate magnetic north when coordinating courses between elements.

e. Communications. Plan for all capable air and maritime assets to monitor the UHF guard frequency as well as the primary tactical frequency. Ground forces may use these frequencies for emergency contact.

f. Mission Designation. Use standard mission designators to assist in planning, tracking, and deconflicting multiple simultaneous missions. See Appendix H for the standard SO mission designation system.

8. UW Planning Considerations. UW planning must consider the nature of the insurgency to be supported. Each insurgency is unique and no insurgency follows a particular model exclusively. The JFSOCC selects and recommends a UW strategy consistent with international law, national and theater objectives, and the operational environment in the target country. Regardless of the strategy finally approved, a US-sponsored UW campaign normally passes through the following seven phases.

a. Psychological Preparation. This activity is initiated as far in advance as possible. PSYOP prepare the insurgent organization and the civil population of a targeted country to accept US sponsorship and the subsequent assistance of SOF. The activities of the JFSOCC in this phase include working with the theater intelligence architecture to identify potentially exploitable insurgent movements (UW targets) and coordinating through the theater combatant commander for

PSYOP support. This coordination involves the Department of State and other relevant agencies. The Department of Defense is seldom the lead agent in this phase. The JFSOCC functions in a supporting role and should be the conduit for coordinating military activities. During this phase the JFSOCC begins the SO mission planning process as outlined in Joint Pub 3-05.5.

b. Initial Contact. US Government agencies other than the Department of Defense normally establish the first contact with an insurgent organization. If possible, the JFSOCC should arrange to exfiltrate an insurgent leader (termed an asset) from the proposed operational area to brief all concerned. When tasked by appropriate authority, the JFSOCC commits an SF pilot team to conduct a thorough assessment of the current situation and insurgent potential within the proposed operational area. This assessment should include an evaluation of the compatibility of US goals, objectives, and methods with those of the insurgent leadership. The SF pilot team may be augmented by PSYOP, civil affairs, engineer, medical, communications, and other specialists. After the pilot team reports, the JFSOCC provides a formal estimate of the situation to the theater combatant commander. Based on the situation, the JFSOCC may recommend supporting the insurgency from external bases, channeling US support through surrogates, or employing SOF elements within the operational area to work directly with the insurgent organization.

c. Infiltration. If the decision is made to employ SOF elements within the operational area, the JFSOCC is responsible for the infiltration of those elements. The MPA and supporting agencies plan and conduct the infiltration (see Chapter IV).

d. Organization. Whether operating inside or outside the JSOA, directly with the insurgent organization or through surrogates, SOF elements provide advice to the insurgent leadership and assist in organizing the insurgent movement for UW operations within the operational area. The JFSOCC participates in the interagency coordination process at theater level and transmits appropriate politico-military guidance to subordinate commanders.

e. Buildup. During this phase (which is often concurrent with the organization phase), the JFSOCC coordinates the operational support and logistic sustainment of the organizational buildup within the JSOA. Operational support may be provided by the theater SOC, other theater components, or other US Government

agencies. Logistic sustainment may come from theater or USSOCOM operational project stocks, the theater supply system, or the supply systems of other US Government agencies.

f. Combat Employment. The JFSOCC continues to support and sustain UW operations. If conventional operations are initiated, the JFSOCC coordinates and deconflicts insurgent activities and assists in planning any linkup between insurgent and conventional forces. The JFSOCC also plans and coordinates for the employment and sustainment of insurgent forces after linkup.

g. Demobilization. The JFSOCC begins planning for demobilization before the first SOF element deploys. As combat operations end, the JFSOCC coordinates insurgent demobilization and plans for SOF exfiltration and post-mission debriefing. Because the influence of deployed SOF may diminish as the insurgents achieve success, the JFSOCC and other involved agencies must guard against unrealistic expectations for SOF demobilization efforts.

9. DA Planning Considerations

a. The JFSOCC plans DA missions to support theater strategic or operational objectives. The JFSOCC and other component commanders nominate DA targets that contribute to the overall success of the theater campaign plan. The JFSOCC validates DA targets through the assessment process described in Joint Pub 3-05.5. For example, destruction of a key bridge to prevent enemy reinforcement against a corps or division attack is normally a tactical mission. It becomes an appropriate SOF mission if the corps or division attack is key to the operational scheme of maneuver and air assets are either unavailable or lack the necessary degree of precision or timing (such as destruction of only one span to allow bridging at a later date). After validating the target, the JFSOCC assesses SOF availability and determines which SOF unit is best suited for the task. For example, a DA mission against a deep inland bridge might be best suited to Army SF, while a bridge located close to an ocean or bay may be better suited to Navy SEALs or SDVs.

b. The probability of DA mission success often depends on the precision with which SOF apply some highly specific form of strength against a correctly identified enemy weakness. When preparing DA mission statements, the JFSOCC should specify the desired effects rather than specific tactical courses of action. The JFSOCC should issue mission-type orders that clearly define the purpose

of the mission. For example, "Disrupt radar coverage of sector X for Y hours" provides planning flexibility to the MPA and the tactical SOF element. "Destroy the radar dish at site Z" unnecessarily restricts planners and could preclude achieving the desired effect.

c. The plan of execution for a DA target should flow from beginning to end with simple, successive steps and a minimum of coordinated or interdependent action. Many targets will have their own specific complexities and the need to concentrate friendly strength against the vulnerabilities of an otherwise stronger enemy will impose further complexities of time and space. This being the case, it is imperative that SO planners accept only those complexities mandated by the target and its surroundings; they should accept additional risk rather than build additional complexity into the plan. Examples of self-imposed complexity include overcompartmentation of information, ambiguous chains of command, complicated and time-sensitive linkup plans, and movement of multiple elements over multiple routes.

d. DA missions often depend on the application of concentrated combat power by a small force in the narrowly circumscribed time and space of the actual actions in the objective area, followed by a rapid withdrawal before the enemy can retaliate by introducing superior combat power into the local area. Unlike conventional military forces that use mass to accomplish these goals, SOF minimize force levels and instead rely on stealth and unconventional tactics and techniques to achieve them. The size of a DA force should be as large as the nature of the target requires and transportation restraints permit, but small enough not to significantly increase the risks of early detection and massive reaction by the enemy once the action occurs.

e. Surprise is an absolute precondition in DA missions. Overall force ratios are usually so unfavorable that there is no chance of success if the enemy is alerted in time to concentrate a reaction force. Loss of surprise is normally a valid abort criteria to cancel, delay, or redirect the operation to an alternate target. For this reason, strict operations security (OPSEC) is vital and cover and deception activities are essential. The most successful DA missions treat cover and deception not as complementary activities but as an integral part of the mission planning process.

f. DA missions must be planned down to the smallest detail, yet the plan must be flexible enough to allow for rapid improvisation to deal with the unexpected.

Unexpected difficulties will almost certainly arise during mission execution, and the DA force will not have the combat power to deal with them using the broad mission-type orders favored by US conventional forces. Instead, SOF deal with the unexpected by:

(1) Making DA forces self-contained to eliminate the requirement for external coordination during critical moments.

(2) Respecting the principle that DA missions are planned from the bottom up by the same people that will execute them, not only to use their efforts to perform the mass of detailed planning but also to make them the owners of the plan, including the full repertoire of courses of action rejected in the planning process but retained in the collective memory of the force and thus available for instant reference if needed.

(3) Using an iterative planning and rehearsal process that evaluates plan feasibility, inculcate the basic plan so fully that no instructions will be needed on the scene unless unexpected difficulties occur, and test any number of plan alternatives that the DA force can implement without detailed new instructions should circumstances change and make them viable (see Chapter V for further discussion of the planning and rehearsal process).

(4) Instilling in SO personnel a mind-set that stresses individual initiative rather than the rote execution of small-unit battle drills.

10. SR Planning Considerations. The JFSOCC must be fully aware of the collection techniques planned for each SR mission, ensuring that they are legal within the specific operational environment. These techniques may include battlefield reconnaissance and surveillance, low-level source operations, hydrographic reconnaissance, clandestine collection, and technical collection. Some missions may require interagency coordination and national oversight. During the planning process, the JFSOCC must consider the lead time required to prepare for, obtain, process, and report SR information. SR mission taskings must specify when information is needed from the deployed SOF elements. In some situations, the lead time is so great that the JFSOCC may need to request authorization for pre-hostility or cross-border operations.

11. FID Planning Considerations. The JFSOCC advises the theater combatant commander on the best approach for

employing SOF to accomplish theater FID objectives. For example, certain tasks may be best accomplished by incorporating SOF trainers and advisory personnel into combined exercises, security assistance programs, small unit or personnel exchanges, or other means. The JFSOCC requests information on past, present, or future programs from the appropriate US Country Team and other agencies and components. Additionally, the JFSOCC may sponsor an area assessment and pass the assessment, along with the Ambassador's statement of goals and objectives and the country AIASA, to the MPA. Although not directly involved with developing terms of reference and status of forces agreements, the JFSOCC should advise the theater combatant commander of their impact on employed SOF.

12. CT Planning Considerations. The JFSOCC must anticipate and coordinate extensive support (including mobility) for theater in-extremis CT forces to enable rapid response. This planning must be done before an incident occurs.

## CHAPTER V

## CONDUCTING SPECIAL OPERATIONS

1. General. SOF conduct operations in peace, conflict, and war. This chapter provides joint SO operational procedures for mission execution, deconfliction, and evaluation.

2. Peacetime Activities. The peacetime activities of SOF derive from the theater combatant commander's peacetime strategy or campaign plan. SOF can demonstrate US resolve and commitment and may influence events without introducing major combat forces. SOF can gain access and influence in foreign nations where the presence of conventional US forces is unacceptable or inappropriate. They can also ameliorate the underlying conditions that are provoking a conflict in an effort to preclude open hostilities. The DOS or another non-DOD agency is often the lead agency for SOF peacetime activities. Any SO conducted within a HN must be fully coordinated with the US Mission and the HN government. SOF peacetime activities include operational training and deployments, security assistance, combatting drugs, and humanitarian assistance.

a. Operational Training and Deployments. Operational training and deployments encompass the day-to-day operations of SOF throughout the world. SOF participate in joint and combined exercise and training programs primarily to prepare for conducting their assigned missions during conflict or war. However, SOF participation in these programs strengthens collective engagement, reinforces capabilities to conduct multinational operations with alliance and likely coalition partners, and establishes an international sympathetic infrastructure of multinational contacts that may be useful during a crisis. To extract maximum benefit from operational training and deployments, the following guidelines normally apply:

(1) Because many SOF training and exercise events focus on building the language and instructional skills required to accomplish foreign training and advisory duties, they may also have ancillary benefits to the host nation. When properly scheduled and conducted, SOF deployments and exercises achieve long-range theater peacetime objectives while producing trained and ready SOF.

(2) The US Ambassador is the personal representative of the President and the Chief of the US Mission to the country. He is responsible for the direction, coordination, and supervision of all US Government



activities within the country, except for those under the authority of a US military area commander (for example, a JFC conducting a joint and combined exercise within the country) or the chief of another US Mission (for example, one accredited to an international organization).

(3) The SAO normally serves as the focal point on the Ambassador's staff for managing security assistance functions within the country. In the absence of an SAO, the US DAO may perform these functions.

(4) As theater JFSOCC, COMSOC coordinates SOF exercise participation, to include coordinating participation of CONUS-based SOF with USSOCOM. The JFSOCC notifies USCINCSOC of the scope and objectives of planned exercises so that USCINCSOC can identify SOF training requirements that may be satisfied during the exercise.

(5) The COMSOC, through the SAO and with representatives of the HN military, identifies the type of SOF training that would most benefit the HN. The theater JFSOCC, USSOCOM, SAO, and HN military staffs work together closely to achieve OPLAN-driven training requirements and theater peacetime objectives while also enhancing HN capabilities. This must be done carefully, as any training conducted primarily for the purpose of assisting the HN is controlled by the Foreign Assistance Act (and/or Arms Export Control Act) and may violate the law unless conducted as a security assistance program.

(6) The COMSOC normally approves training and exercise plans prepared by CONUS-based SOF.

(7) The COMSOC normally serves as JFSOCC for large exercises and retains direct OPCON of participating SOF. For smaller exercises and training events, the COMSOC may establish a subordinate JSOTF to serve as exercise JFSOCC. When a small SOF element deploys to a HN independently, it normally trains under the OPCON of the SAO with the COMSOC ensuring adequate support for the training.

**b. Security Assistance, Combatting Drugs, and Humanitarian Assistance.** SOF normally conduct and support these activities under the control of non-DOD lead agencies. The COMSOC, however, normally performs the following functions for the theater commander:

(1) The COMSOC coordinates closely with the lead agency to identify, plan, and coordinate SOF support. When possible, the COMSOC assesses the applicable programs and their objectives to make recommendations on optimum employment of SOF. Because of the limited forward stationing of SOF, most forces will come from CONUS. This requires the COMSOC to articulate clear mission requirements to USCINCSOC. The JFSOCC should review the plans of allocated SOF before they deploy and work with the lead agency and USCINCSOC to correct any problems. If these problems are inherent to the operation, the COMSOC will recommend that the theater combatant commander inform the appropriate higher authority.

(2) The COMSOC coordinates the transfer of authority to the gaining agency.

(3) The COMSOC should maintain communications with and monitor the activities of SOF under the authority of other agencies. This permits the COMSOC to keep the theater combatant commander informed and provide required support. When circumstances in the theater warrant, the COMSOC may be directed to divert SOF from their current mission to a new one of higher priority. Further, the COMSOC can ensure that joint SO activities under his control complement, or at least do not conflict or compete with, SO activities not under his OPCON.

(4) Upon mission completion, the COMSOC coordinates the transfer of authority back to military control. He ensures forces are debriefed, enters lessons learned into the JULLS data base, and initiates any appropriate action (revised or new training, follow-on missions, etc.).

3. Conflict. Not all SOF operational deployments involve peacetime activities in a permissive environment. SOF also deploy in conflict situations to assist in terminating the conflict on favorable terms before the conflict requires a crisis response by the United States. In a conflict situation, SOF may be able to preclude a crisis or minimize its effects on the United States by providing support to a foreign power's counterinsurgency or insurgency operations.

a. Support for Counterinsurgency. When subversion, lawlessness, or insurgency threaten a friendly nation's stability, the NCA may direct US forces to provide support to the friendly nation's counterinsurgency efforts. This support is distinct from FID training or advisory assistance performed under security assistance

programs because it involves the operational commitment of US forces and may require notification of Congress under the War Powers Act. SOF participate in this interagency effort by performing operational FID missions, either unilaterally or as part of a larger military operation. When acting unilaterally, the COMSOC retains direct OPCON of the committed SOF or establishes a JSOTF under the SOC for that purpose. The theater combatant commander normally establishes a JTF to control larger operations; the JTF commander normally has a subordinate JSOTF as JFSOCC.

b. Support for Insurgency. When the US Government chooses to support an insurgent or resistance movement directed against a hostile government or occupying power, the NCA may direct US forces to provide support to the insurgent or resistance movement's efforts. US support to insurgent or resistance movements are normally clandestine or covert in nature. All such programs are conducted as special activities and subject to established procedures for review, approval, coordination, and notification to Congress. The role of SOF in such an interagency effort is to organize, train, advise, and sustain insurgent or resistance forces conducting unconventional warfare against the hostile government or occupying power. The COMSOC may control these forces, either directly or through a subordinate JSOTF, or he may provide forces and resources to another agency that has the lead.

4. Crisis Response. At any time, the NCA may task theater combatant commanders to conduct military operations in response to a crisis. The theater JFSOCC normally exercises OPCON of forces conducting joint SO in response to a crisis. These operations frequently require detailed interagency coordination. In time-sensitive crisis situations, the JFSOCC must take advantage of opportunities for forward-deployed SOF to transition to the new mission. Forward-deployed SOF can gather critical information, undermine a potential opponent's will or capacity to wage war, enhance the capabilities of friendly multinational forces, or support the introduction of US contingency forces.

5. War. The NCA may direct the theater combatant commander to conduct contingency operations or sustained military operations in response to open hostilities in the theater. During such operations, the Department of Defense is normally the lead agency and the theater combatant commander is normally the supported CINC. The COMSOC may establish a JSOTF to execute joint SO under the OPCON of a JTF established to conduct a contingency operation. This arrangement allows COMSOC to continue functioning at the

theater level. The COMSOC normally serves as the JFSOCC in a major contingency operation or when a contingency operation evolves into sustained military operations. The COMSOC may divide the theater SOC staff so that SO outside the theater of operations and long-term planning may continue. This latter arrangement is preferred when the theater combatant commander personally commands the overall military operation.

a. During the initial phase of a contingency operation, the COMSOC must smooth the transition from pre-crisis operations by performing the following functions:

(1) Control the flow of SOF into theater.

(2) Establish communications.

(3) Reconfigure deployed SOF to support the operation (This may require diverting SOF from other missions and changing their command and support relationships).

(4) Ascertain, monitor, and report the readiness status of assigned, attached, and allocated forces.

(5) Transition the SOC to a fully operational configuration. This may include deploying to the operational area and establishing a joint operations center (see Appendix C for further details) capable of performing current operations and planning functions on a 24-hour basis. The JFSOCC must be able to maintain C2 during headquarters deployment. This requirement dictates use of an advance echelon to assume C2 functions during deployment of the main body. The JFSOCC must ensure adequate communications are established to support transfers of C2 throughout the deployment process.

(6) Establish appropriate liaison. As a minimum, this requires placing liaison elements with the theater JOC, other theater components, supported headquarters, and appropriate non-DOD agencies and foreign forces. These liaison requirements must be identified during the deliberate planning process for resources to be available when operations begin. (See Appendix D for further detail.)

(7) Coordinate, define, and establish additional intelligence support to augment current or planned intelligence architectures.

b. During the employment phase, the JFSOCC commits forces at the direction of the JFC. As the situation

develops, the JFSOCC recommends further SOF employment through the joint targeting process. The JFSOCC tasks SOF commanders for emerging missions, approves their tactical plans, and ensures they receive adequate support. The JFSOCC, through liaison elements, also ensures that SOF plans and operations are synchronized and deconflicted with those of the other components.

c. Detailed coordination with the JFC and other component commanders is essential to prevent fratricide. Beyond this, the JFSOCC must also establish and maintain reliable control procedures for deployed forces. The JFSOCC must also maintain continuous control of elements under his OPCON and deconflict their activities with other forces operating in the vicinity. When required, the JFSOCC coordinates the details of SOF linkup with conventional forces to prevent fratricide.

d. The JFSOCC exercises OPCON of assigned and attached forces through a structured planning process (see Chapter IV) and by establishing C2 procedures tailored to meet specific mission requirements (see paragraph 5 below).

e. The JFSOCC receives reports from deployed elements through their parent units and directs the information to the supported commander and theater intelligence architecture as appropriate. When necessary, the JFSOCC may provide a liaison element with appropriate communications to a supported commander to enable direct transmissions from supporting SOF. If the communications system will not allow multiple stations to monitor transmissions, the liaison element at the supported headquarters immediately retransmits reports to the JFSOCC. The JFSOCC distributes the information to other supported commanders and the theater intelligence architecture. In situations where employed SOF conduct missions within an area under the control of a conventional ground or maritime commander, TACON of those SOF may be passed to that commander to maintain unity of command. When this occurs, TACON should return to the JFSOCC upon mission completion.

f. The JFSOCC informs the theater combatant commander when developments may affect the campaign. Information must also flow laterally to and from other components. The JFSOCC must know the disposition of any conventional forces that may impact SOF missions being planned or in progress. The JFSOCC should be particularly alert to abrupt changes in schemes of maneuver, ship-to-shore movement, fire support plans, free-fire zones, or diversions of air strikes.

g. Coordinating and deconflicting SO with joint air operations is critical. Generally, SO involve air or surface operations that transit the airspace control area, the air defense area, or a joint operations area. The JFC normally designates a JFACC, whose authority and responsibilities are defined by the establishing JFC. Although the JSOACC may coordinate special air operations directly with the JFACC, the JFSOCC normally collocates a special operations liaison element with the JFACC for this purpose. The SOLE facilitates consistent and expeditious coordination of SOF air and surface operations with the JFACC. It synchronizes and integrates SO with joint air operations through the air tasking order system, prevents duplicative targeting, resolves airspace conflicts, and coordinates to avoid fratricide.

h. To effectively coordinate and deconflict SO with conventional operations, the JFSOCC must have an effective and easily understood means of communicating the status of each ongoing mission to the liaison elements. The combination of descriptive mission designators and a nominal status would allow a liaison officer to track a large number of missions. A simple status system based on colors might look like this:

(1) GREEN. Positive confirmation that the mission is proceeding as planned.

(2) AMBER. Last positive confirmation had the mission proceeding as planned. No reconfirmation has been received for over 12 hours.

(3) RED. Either confirmation that the mission is not proceeding as planned, or more than 24 hours has passed since the last planned contact.

6. Mission Execution. The JFSOCC may direct mission execution personally, or he may delegate directive authority (OPCON or TACON) to a subordinate commander.

a. The JFSOCC normally delegates OPCON to a component commander for missions conducted primarily by a single SOF element, such as a DA or SR mission conducted by a single SF operational detachment or SEAL platoon. Although the JFSOCC and component commanders are heavily involved in the targeting and mission planning process, the component commanders normally direct a SF battalion, NSWTU, SOS, or similar SOF tactical commander to exercise C2 during mission execution. The JFSOCC and component commanders monitor execution and deconflict friendly activities that could adversely affect the mission.

Figures V-1 and V-2 depict mission and mission support status matrixes the JFSOCC and component commanders can use to assist in monitoring mission execution. The JOC should also post mission status on its situation maps using the SO mission designation system outlined in Appendix H. As an exception to normal C2 procedures, the JFSOCC or a component commander may exercise direct C2 as the SOF tactical commander of larger and more complex SO missions, such as a special mission unit (SMU) hostage rescue or a Ranger battalion airfield seizure.

b. The SOF tactical commander actively participates in mission preparation (concept development, briefbacks, rehearsals, communications exercises) and all phases of execution from staging and infiltration to postmission evaluation.

7. Concept Development. The NCA or JFC normally nominates and designates SOF targets. The tactical commander may have only limited input to the initial targeting process, and the original mission concept may be directed by higher authority. Political and strategic or operational military considerations may dominate tactical considerations at this stage of the mission. The tactical commander must ensure that such considerations do not unduly jeopardize mission success or create unacceptable risk to the operational elements committed to the mission.

8. Briefbacks. Briefbacks are decision briefings given by commanders of SOF operational elements to the SOF tactical commander to secure approval of their plans of execution and convince the tactical commander that their elements are fully mission-capable. The tactical commander normally requires briefbacks from each participating element commander before mission execution. Detailed briefbacks are an integral part of mission planning because they:

a. Require subordinate element commanders to conduct a detailed mission analysis and estimate.

b. Facilitate understanding of the detailed plan of execution by all participating personnel.

c. Provide the tactical commander the opportunity to evaluate the element's plan of execution and provide additional guidance and direction if required.

9. Rehearsals. Rehearsals of key actions, especially actions in the objective area, are a vital part of SO mission preparation.

Figure V-1. Sample Mission Status Matrix

MSN	D-7 _FEB	D-6 _FEB	D-7 _FEB	D-6 _FEB	D-5 _FEB	D-4 _FEB	D-3 _FEB	D-2 _FEB	D-1 _FEB	D+DAY _FEB	D+1 _FEB	D+2 _FEB	D+3 _FEB	D+4 _FEB	D+5 _FEB
	MITASK	ISO	MICON	MCA		REHEAR	MSC	BB	INFIL	SR				→	EXFIL
	MITASK	ISO	MICON	MCA		REHEAR	MSC	BB	INFIL	SR				→	EXFIL
	MITASK	ISO	MICON	MCA		REHEAR	MSC	BB	INFIL	SR			→	EXFIL	
	MITASK	ISO	MICON	MCA		REHEAR	MSC	BB	INFIL	SR				→	EXFIL
		MITASK	ISO	MICON	MCA	REHEAR	REHEAR	MSC	BB	INFIL	DA				→
		MITASK	ISO	MICON	MCA	REHEAR	REHEAR	MSC	BB	INFIL	DA				→
	MITASK	ISO	MICON	MCA		REHEAR	REHEAR	MSC	BB	INFIL	UW			RES	→
	MITASK		ISO	MICON	MCA		REHEAR	REHEAR	MSC	BB	INFIL	UW			RES
		MITASK		ISO	MICON	MCA		REHEAR	MSC	BB	INFIL	DA		→	EXFIL

LEGEND:  
MITASK Mission Tasking  
ISO Isolation  
MICON Mission Concept  
MCA MICON Approval  
REHEAR Rehearsal  
MSC Mission Support Confirmation  
BB Briefback  
INFIL Infiltration  
RES Resupply  
EXFIL Exfiltration



MISSION SUPPORT REQ #	CONFIRMATION MESSAGE DTG	MISSION DESIGNATOR	AIRCRAFT/ VESSEL #	ETD (Z)	ETA (Z)	DEPARTURE POINT (LAT/LONG)	EALT (Z)	TOT (Z)	DESTINATION (LAT/LONG)	TERMINATION POINT (LAT/LONG)	ETR (Z)

Figure V-2. Sample Mission Support Matrix

a. Conventional plans are normally prepared by staff officers sensitive to the capabilities and limitations of the force that will ultimately execute the plan. Conventional forces rehearse a plan primarily to learn it, not to evaluate and improve it. The level of training is taken as a given that cannot be changed significantly before mission execution. Indeed, the plan must take into account the level of training of the force that must execute it.

b. In the case of SOF, however, the planners, trainers, and operators are all the same people. Rehearsals evaluate and validate planned tactical actions and control measures and provide feedback that may cause the plan to change. The rehearsals also serve to train SOF personnel in new skills that are required to execute the plan. The participating SOF elements and their individual members learn the plan to a standard that enables them to perform key actions from start to finish at a high tempo without needing any detailed instructions during mission execution.

c. The tactical commander supervises an iterative process of planning, rehearsal, plan modification, and more rehearsal until preparation time runs out or the force is satisfied with the plan. This process exploits the collective wisdom of the entire force to improve the plan and develop a range of options that can be rapidly implemented or modified to improvise a response to unexpected difficulties that prevent execution of the basic plan. Options rejected as inferior during mission preparation may suddenly become superior during mission execution. Rehearsals thus enhance the probability of mission success and reduce unnecessary losses of personnel and equipment.

d. For both planning and training purposes, rehearsals should be as realistic as possible. If time and resources permit, rehearsals should be conducted with realistic mock-ups in real time, including, if possible, idle intervals. Real-time rehearsals identify the inherent effects of time on the SO force and its activities and provide an essential element of realism to the rehearsal. The effects of many days at sea or many hours in low-level flight can alter significantly the performance of the force during actual mission execution.

10. Communications. The critical importance of communications in SO mission execution cannot be overemphasized. Communications exercises test the operational status of equipment, communications interoperability, operator knowledge of procedures and

formats, and validity of the overall communications plan. The tactical commander should conduct communications exercises as part of all full-scale rehearsals and at least once before mission execution if limited time precludes a full-scale rehearsal. All elements, aircraft, maritime vessels, and other support assets participating in the mission must participate in the exercise. One method for conducting a communications exercise is to have designated personnel make all transmissions required by the execution checklist over the appropriate net.

11. Execution Checklist. The complex level of operational detail in a DA or CT operation often requires use of an execution checklist (see Appendix G) for synchronization. The success of a complex DA or CT mission may depend on the development of an effective execution checklist during planning and rehearsals.

12. Command and Control. The SOF tactical commander can choose from several options to exercise C2 over operational elements during mission execution.

a. Control from Operations Base. The tactical commander may control the mission from the operations base. This option provides a stable C2 environment, maximum availability of staff personnel, and established communications of proven reliability. However, commanding an operation from the operations base removes the tactical commander from the scene of the action and limits the commander's ability to visualize the operation and make necessary corrections to the plan of execution. The tactical commander exercises this option by delegating OPCON or TACON to an on-scene commander who is normally the senior element commander. The SOF operational elements normally communicate directly with the tactical commander, who reports the status of operational elements through the component commander to the JFSOCC.

b. ABCCC Control. The tactical commander may control the mission from an airborne command and control center (ABCCC) aircraft. This option provides effective, redundant communications systems and places the tactical commander and battle staff in close proximity to the operation. However, it also places the tactical commander at great risk in a high-threat environment and may increase the likelihood of early mission compromise. The tactical commander exercising this option should still delegate OPCON or TACON to an on-scene commander. The SOF operational elements normally communicate directly with the tactical commander, who reports the status of operational elements to the JFSOCC. The

battle staff aboard the ABCCC should include the senior aviation commander, operations officer, intelligence officer, signal officer, an air planner, a joint fire support element, and an operations staff officer from each unit participating in the operation.

c. Assault Command Post. The tactical commander may accompany the assault echelon and exercise C2 from an assault CP. This option provides the greatest access to on-scene events but limits communications and staff accessibility and places the tactical commander in risk of becoming decisively engaged and unable to exercise proper C2 at a crucial moment. The tactical commander exercising this option should consider placing the deputy commander in the base operations center or ABCCC aircraft to forward reports, coordinate mission support as required, and assume C2 should the need arise. The composition of an assault CP is similar to that of an ABCCC battle staff, with the addition of communications and security personnel and a tactical air control party.

13. Mission Deconfliction. The JFSOCC must deconflict SO activities with other joint force component commanders to avoid fratricide. This process can be difficult when the SO activity is highly classified and compartmented. The JFSOCC must balance legitimate OPSEC considerations against the need to coordinate and deconflict such activities. To assist in this process, the theater combatant commander should establish procedures for the coordination and deconfliction of compartmented SO activities.

a. Special Air Operations. The JFSOCC deconflicts special air operations through the use of the special operations liaison element at the JFACC staff or the appropriate Service component air force headquarters (Air Force AOC, Marine TACC, or Navy Strike Warfare Commander).

(1) Avoid interception by friendly aircraft by incorporating SOF air missions into the joint air tasking order (ATO). This document is published by the JFACC or COMAFFOR and normally requires submission of key mission information NLT 48 hours before execution or 24 hours before the start of the ATO day. The short suspense of certain SOF air missions may dictate late submission.

(2) Avoid fire from friendly air defense systems by having SOF aircraft use identification of friend or foe (IFF) procedures and by coordinating with the appropriate airspace control authority (ACA) and area air defense commander(s) (AADCs).

(3) When OPSEC precludes the use of these normal procedures outlined in Joint Pubs 3-01.3, 3-52, and 3-56.1, the JFSOCC may place LNOs aboard the airborne warning and control system (AWACS) aircraft to deconflict specific SOF air missions during execution.

b. Special Operations on Land. The JFSOCC deconflicts SO on land through the use of LNOs and SOCCEs at appropriate joint and land force headquarters (i.e., corps, Marine expeditionary force, division, or landing force, depending on the actual situation).

(1) Deconflict indirect fires and air strikes through the use of restricted fire areas (RFAs) or no-fire area (NFAs). These fire control measures are established by:

(a) The JFSOCC within a joint special operations area (JSOA).

(b) The appropriate area commander when SOF tactical elements are operating within that commander's area of operations (AO).

(c) The JFC beyond the boundaries of subordinate area commanders.

(2) Deconflict ground maneuver through the use of face-to-face coordination by LNOs or SOCCEs at the appropriate land force headquarters.

(a) When SOF tactical elements operate within the boundaries of a conventional area commander, the JFC may establish within the area an AO for which the JFSOCC is responsible. Alternatively, the JFC may direct the JFSOCC to transfer OPCON or TACON to the conventional area commander, who then becomes responsible for deconfliction.

(b) Consider placing LNOs with the lead elements of a conventional unit conducting linkup operations with SOF elements.

c. Maritime Special Operations. The JFSOCC deconflicts maritime SO through the use of LNOs at the JFMCC staff (if designated) and appropriate Navy force headquarters (i.e., battle group or amphibious task force).

(1) Deconflict indirect fires, air strikes, and maritime maneuver with the appropriate composite warfare commander:

- (a) Antiair warfare commander (AAWC) for airspace control and air defense.
- (b) Antisurface warfare commander (ASUWC) for surface maneuver and naval gunfire.
- (c) Antisubmarine warfare commander (ASWC) for subsurface maneuver.
- (d) Strike warfare commander (STWC) for all aspects of offensive naval air operations against land targets using tactical air and cruise missile assets as well as for air support to ground forces (including SOF), mine warfare operations, and strike rescue planning.

- (2) Deconflict littoral and riverine SO using procedures outlined for SO on land.

14. Mission Evaluation. After each SO activity, the JFSOCC should evaluate SOF effectiveness. After-action reports and formal debriefings complete the mission planning and execution cycle. SOF commanders should submit after-action reports in accordance with Joint Pub 1-03.30. SOF planners and operators should review the results of previous missions, the joint universal lessons learned system (JULLS) data base and the SO debrief and retrieve system (SODARS) within SOCRATES for insights applicable to current and future training and operations. USSOCOM should maintain SO data bases of compartmented lessons learned. During peacetime, these data bases provide continuity for a long-term regional security program that builds incrementally through many small-scale activities. During conflict and contingency operations, mission feedback can assist SOF commanders in exploiting enemy vulnerabilities or warn against unforeseen enemy capabilities. The JFSOCC should review all mission after-action reports and ensure that relevant lessons learned are incorporated into unit SOPs and submitted to the JULLS and SODARS. The COMSOC should ensure that SOF leaving the theater are thoroughly debriefed. If debriefing occurs outside the theater, USCINCSOC must provide the COMSOC a copy of the report.

- (e) Airfield warfare commander (AAWC) for airbase control and air defense.
  - (d) Airfield warfare commander (AWWC) for airbase maneuver and naval gunfire.
  - (c) Amphibious warfare commander (AWC) for amphibious maneuver.
  - (b) Strike warfare commander (STWC) for all aspects of offensive naval air operations against land targets using tactical air and cruise missile assets as well as for air support to ground forces (including POW), mine warfare operations, and strike resource planning.
- (2) Decennial littoral and riverine SOA training procedures outlined in Section I.A.
- 14. Mission Evaluation.** After each activity, the JCSOC should evaluate SOA effectiveness. After-action reports and formal debriefings complete the mission planning and execution cycle. SOA commanders should submit after-action reports in accordance with Joint Pub 3-02.30. SOA planners and operators should review the results of previous missions and the joint universal lessons learned system (JULLS) data base and the SOA debrief and retrieve system (SODARS) within 30 days for insights (INTENTIONALLY BLANK) and future training and operations. USJCSOC should maintain SOA data bases of computerized lessons learned. During post-mission passes of computerized lessons learned, a long-term regional security program that builds incrementally through many small-scale activities. During conflict and contingency operations, mission feedback can assist SOA commanders in exploiting enemy vulnerabilities or warn against unforeseen enemy capabilities. The JCSOC should review all mission after-action reports and ensure that relevant lessons learned are incorporated into SOA SOPs and submitted to the JULLS and SODARS. The COMSOP should ensure that SOA leaving the theater are thoroughly debriefed. If debriefing occurs outside the theater, USJCSOC must provide the COMSOP a copy of the report.

## CHAPTER VI

## INTELLIGENCE SUPPORT OF SPECIAL OPERATIONS

1. General. Timely, detailed, tailored, and fused all-source intelligence is vital to SO mission planning. As the command's senior intelligence officer, the SOJ2 must clearly and fully understand the mission, commander's intent, characteristics of the area of operations, and the capabilities, operational procedures, and availability of SO forces. The SOJ2 provides the JFSOCC an estimate of enemy and relevant third party (friendly and neutral powers) strengths, weaknesses, vulnerabilities, objectives, and probable courses of action (see Joint Pubs 2-0 and 2-01). The SOJ2 is also responsible for counterintelligence support to joint SO (see Joint Pub 2-01.2). Finally, the SOJ2 actively assists operational planners in SO targeting (see Joint Pub 3-05.5).

2. SO Intelligence Requirements. The currency, level of detail, and scope of SO intelligence requirements place unusual demands on theater and national intelligence systems. (Joint Pub 3-05.5 contains appendixes of SOF essential elements of information.) SO require more collection, research, analysis, and textual elaboration than most conventional missions. HUMINT is especially important to SO mission planning because it provides detailed information not usually available through technical means. Graphics and imagery are likewise very important to SO. Detailed information from theater and national sources must be tailored so that it can be displayed, understood, and used by the tactical SOF element that will plan and conduct the mission. Recent (less than 24 hours old) detailed imagery of the objective area is normally needed. Some missions may also require replicas, models, diagrams, and nonstandard mapping, charting, and geodesy products. The scope of SO intelligence requirements may include the social, economic, and political dynamics of the operational area. The JFSOCC's information requirements compete for limited collection resources and all requirements may not be satisfied. JFSOCC intelligence requirements linked to theater EEI will have the best prospects for timely support.

3. Collection Management. Much of the intelligence required for SO mission planning is already available within the intelligence community. After determining SO intelligence requirements, the SOJ2 manipulates intelligence data bases to identify existing information and shortfalls. The SOJ2 then generates and prioritizes SO collection requirements based upon the JFSOCC's EEI. The SOJ2 collection plan translates



these requirements into specific missions (to subordinate component commanders) or requests for information (to higher headquarters and supporting intelligence organizations). The SOJ2 collection manager monitors collection taskings and requests to prevent unnecessary duplication of effort, establish new priorities in response to changes in the intelligence estimate, and ensure timely response to the requesting units.

a. Exploitation. Because SOF components have extremely limited organic intelligence collection and processing resources, national and theater assets are the primary sources of SOF intelligence information. SOF rely on the collection, analysis, and production capabilities of theater and national intelligence agencies.

b. Systems. Intelligence data normally flows to the JFSOCC through established USSOCOM, theater, or Service component interfaces. "Skip echelon" intelligence support directly from national agencies to a JFSOCC occurs only in extreme circumstances. The SOJ2 acts as the theater SOF collection manager and ensures validated subordinate unit intelligence requirements are incorporated into the theater intelligence collection plan. The SOJ2 also initiates and develops intelligence relationships with all theater intelligence organizations. The SOJ2 also maintains contact with national agency liaison elements (DIA, CIA, NSA, etc.) at the theater headquarters. These liaison elements can ensure that theater-validated SOF intelligence requirements are addressed rapidly and efficiently within their respective agencies.

4. Analysis and Production. Limited SOF analytical capabilities create a heavy reliance on the national and theater intelligence production agencies. SO require the full array of intelligence products available to conventional forces, such as indications and warning data, orders of battle, threat tactics, weapon systems characteristics and capabilities, communications, environmental, and maritime factors. Additional analytical requirements may include internal security force order of battle information, reaction time and size of opposing forces, weapon systems available to the security force, daily routine and habits of the security force and local population, security force communications, and detailed physical characteristics (such as construction materials) of specific buildings within the target area. The SOJ2 production manager ensures that national and theater analysts fully understand the SOF requirement so that they can provide the proper degree of detail to the tactical SOF consumer in a useful format.

5. Dissemination. The ability to electronically transfer intelligence products provides accessibility to fused national and theater all-source intelligence at the tactical level of execution. The theater intelligence production agencies must have the capability to provide this service. Intelligence community support to SOF must have standardized, compatible systems for intelligence data transfer to a deployed JFSOCC and the subordinate SOF component headquarters. Automated systems available to SOF include:

a. Special Operations Command Research, Analysis and Threat Evaluation System. SOCRATES includes computers, data bases, intelligence communications systems, secure telephones, facsimile equipment, and imagery processing and dissemination equipment. SOCRATES integrates the existing intelligence data handling systems and the DITDS, which hosts a data base specifically focused on terrorism and low-intensity conflict, into a LAN-based multifunctional intelligence support system. SOCRATES also provides access to national level imagery products. Other capabilities include:

- (1) Message handling services.
- (2) Electronic mail.
- (3) File and data base transfer.
- (4) Remote data base access.
- (5) Standard applications.
- (6) Library services.
- (7) Imagery.
- (8) Threat analysis.
- (9) Indications and warning.
- (10) Collection management.
- (11) Commercial news services.
- (12) Automated intelligence reporting.
- (13) Target planning.
- (14) Current intelligence.
- (15) Product generation.

b. Psychological Operations Automation System. POAS is the USSOCOM-managed PSYOP intelligence system that provides worldwide computer-based PSYOP analytical support. This system operates in multiple security environments up to and including TOP SECRET. Eventually, POAS will interface with SOCRATES.

6. Intelligence Communications. Effective SO intelligence support depends on secure and reliable communications systems. The SOJ2 must ensure that standardized intelligence interface procedures between the theater SOF intelligence community, theater intelligence agencies, and the national intelligence community are established, clearly understood and exercised. The SOJ2 also ensures, through the SOJ6, that deployable, interoperable intelligence communications systems (i.e., secure SATCOM, secure telephones and facsimile equipment, secondary imagery dissemination systems, ADP systems) are available and capable of providing near-real-time tailored, fused, intelligence products to the lowest deployed SOF combat echelon.

7. Counterintelligence. Counterintelligence (CI) is a critical force protection asset that offers the JFSOCC varied support including operations, investigations, collection, and threat analysis. The SOJ2 coordinates with the theater CI support officer to acquire theater and national CI support for joint SO. The JFSOCC should consider early deployment of supporting CI teams to establish liaison with HN security forces and the US Country Team. An effective CI program can detect, counter, and where possible, exploit foreign intelligence collection activities directed against SOF. Combined with OPSEC and deception, CI can provide the JFSOCC the security and surprise that are critical to successful SO. Specific CI tasks are discussed in Joint Pub 2-01.2.

8. Intelligence Support to SO Planning. Advance planning for intelligence is essential for successful SO. The very precise information required about operational areas or targets may not be readily acquired by national or theater intelligence agencies. Obtaining information to support SO may require a long-term, high-risk commitment of resources and may also require developing new intelligence sources. The SOJ2 provides SO planners with mission-specific intelligence to support operational decisionmaking and is involved at the earliest stages of mission planning to ensure responsiveness of the intelligence system.

a. Deliberate Planning. During the deliberate planning process, the develops mission-specific intelligence requirements that support the operational objectives of the plan. The SOJ2 should consider:

(1) Priority intelligence requirements and other intelligence requirements.

(2) Existing all-source intelligence collection requirements and collection priorities against the PIR and OIR.

(3) Gaps in the basic intelligence data bases for recommended changes in collection priorities.

(4) Unique intelligence production requirements to execute the assigned SO.

(5) Dissemination of intelligence products.

(6) Intelligence communication and reporting requirements.

b. Time-Sensitive Planning. The SOJ2 must accurately interpret indications and warning data to anticipate potential SO intelligence requirements. Even more than for deliberate planning, time-sensitive planning must state refined, precise requirements for collection. Rapid coordination, timely production, and reliable dissemination are essential.

- (1) Priority intelligence requirements and other intelligence requirements
  - (2) Extending all-source intelligence collection requirements and collection priorities against the RIR and OIR
  - (3) Gaps in the basic intelligence data base for recommended changes in collection priorities
  - (4) Unique intelligence production requirements to execute the assigned SOI
  - (5) Dissemination of intelligence products
  - (6) Intelligence construction and reporting requirements
3. Time-Sensitive Planning. The SOI must accurately interpret indications and warning data to anticipate potential SO intelligence requirements. Even more than for deliberate planning, time-sensitive planning must state refined, precise requirements for collection. Rapid coordination, timely production, and reliable dissemination are essential.

(INTENTIONALLY BLANK)

## CHAPTER VII

## C4 SYSTEMS SUPPORT TO SPECIAL OPERATIONS

1. General. Common to the requirements of all SOF commanders is the need for secure, survivable, and interoperable C4 systems that support force status monitoring and reporting, warning and threat assessment, staff support and decision aids, consultation and communication, and direction and control of forces. SOF C4 doctrine (see Chapters III and V, Joint Pub 3-05) normally favors centralized planning with decentralized execution. SOF commanders normally delegate OPCON to the lowest level that can accomplish the needed coordination. (In some cases, political considerations may require control at higher levels.) Theater combatant commanders must develop and maintain a SOF communications architecture capable of supporting time-sensitive DA or CT missions as well as long-term FID or UW operations, which require integrated long- and short-haul secure communications nets among numerous elements.

a. Timely and detailed planning and preparation can identify and solve most system installation, operation, maintenance, compatibility, and interoperability issues in support of SOF C2 requirements. Current editions of Joint Pub 6-05.1 through 6-05.7 apply.

b. SO communications capabilities provided to a JFSOCC will be under his OPCON and will be an integral part of his C2 system.

2. SOF Communications Capabilities. The JFSOCC must identify SO requirements to obtain adequate, appropriate communications capabilities. The following communications assets routinely support SO signal requirements.

a. The Army 112th Signal Battalion can support concurrently two JFSOCC headquarters, each with up to three component headquarters. The battalion can also support up to 14 SO liaison elements with communications teams. Theater SOF communications priorities for the 112th Signal Battalion are established in Annex E, Joint Strategic Capabilities Plan.

b. When requested by the supported theater combatant commander and approved by the NCA, the JCSE can also support two JFSOCC headquarters concurrently.

c. The support these organizations provide includes the installation, operation, and maintenance of C4 systems at the JFSOCC headquarters and connectivity between the JFSOCC headquarters and each component headquarters and liaison element.

d. The JFSOCC identifies C4 requirements to the theater combatant commander. The theater combatant commander tasks theater assets to fill these requirements or initiates action to acquire assets from the 112th Signal Battalion or the JCSE for JFSOCC support.

3. Automated Planning Tools. The JFSOCC must develop operational procedures providing an interoperable and compatible C4 network. There are automated planning tools available to assist planning for C4 requirements. These tools include:

a. Communications Link Interface Planning System. CLIPS is a knowledge-based computer program that incorporates a data base containing multichannel and single-channel radio equipment characteristics. CLIPS is a fast, accurate tool that simplifies the complicated link planning process. It determines possible combinations of equipment required to establish communications links. The C4 planner can use its output to tailor nets for a specific operational environment.

b. Tactical Network Analysis and Planning System. TNAPS is an integrated set of computer programs designed to automate the planning, engineering, data base development, network analysis, and management of tactical communications networks. Tactical network planning is accomplished at two levels. Network planners are responsible for planning and managing a tactical network as a whole. Nodal planners develop a complete data base for equipment within the node and generate all necessary worksheets and crew assignments sheets. TNAPS does not design the network for the operator. It saves time and enhances the accuracy of the data base, allowing network planners to focus their efforts on design.

4. Baseline SOF C4 Systems. The following paragraphs describe baseline C4 systems for the JFSOCC and each SOF Service component. The accompanying figures depict notional SOF C2 elements and the communications connectivity required between them. Interfaces normally required for SOF C4 are depicted in Figure VII-1. Current C4 connectivity can be found in the USSOCOM SOF C4 System Master Plan. This connectivity will evolve as new C2 elements and new communications systems emerge.

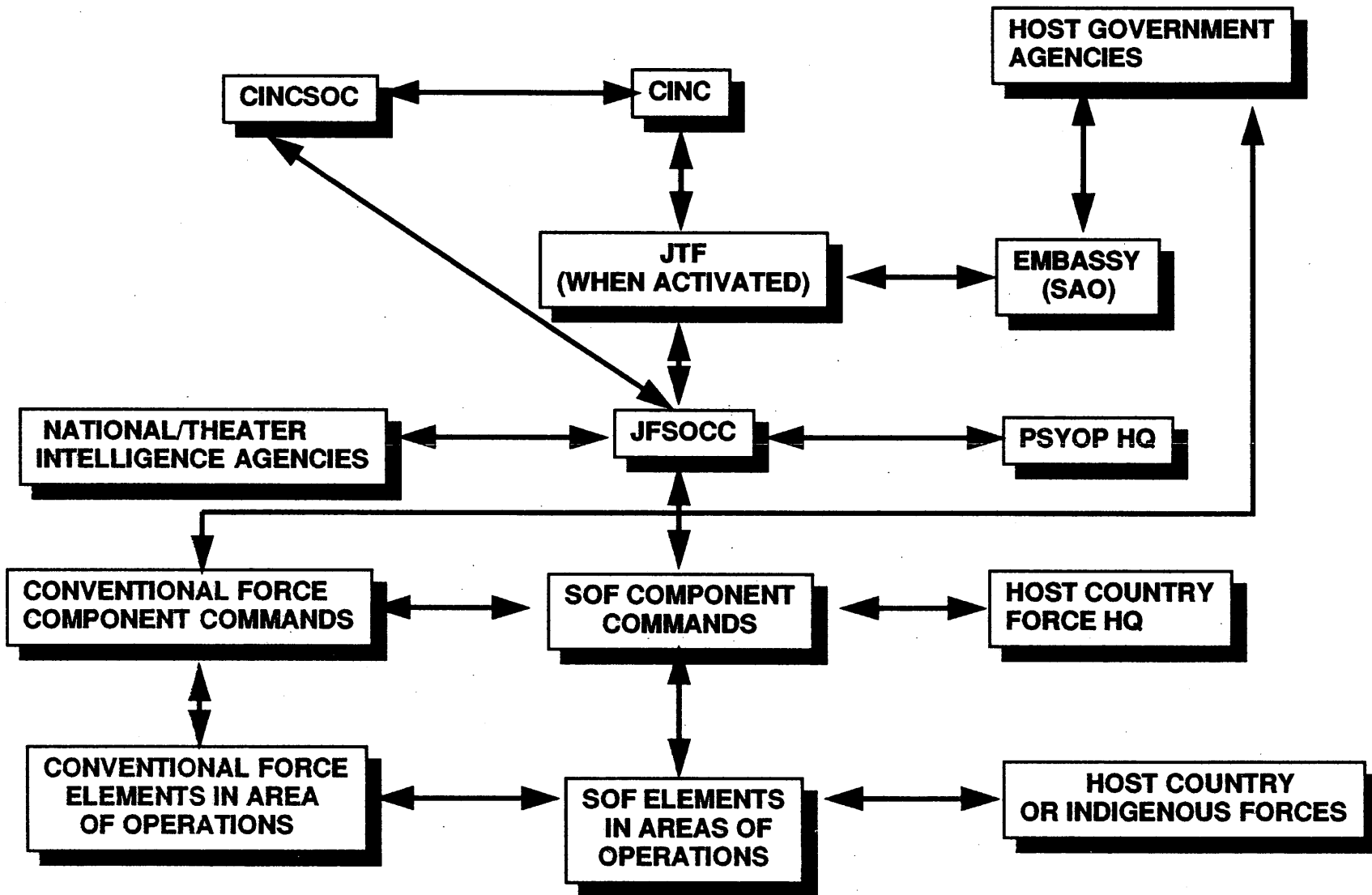

Figure VII-1. Interfaces for SOF C4



5. ARSOF C4 Systems. Figure VII-2 depicts baseline C4 systems for two notional deployed ARSOTFs reporting directly to a JFSOCC.

a. The SFOB-JFSOCC link employs a mix of SHF multichannel, HF (low-power) multichannel and UHF single-channel TACSAT systems. The SHF multichannel link includes channels that satisfy requirements for common-user voice, secure voice, common-user GENSER/SI messages, facsimile, imagery, and point-to-point circuit requirements.

b. The SFOB-FOB link uses HF multichannel and UHF single-channel TACSAT systems.

c. The FOBs communicate with their deployed operational detachments using a mix of man-portable, single-channel UHF (TACSAT) and HF radios.

d. The Army Special Operations Communications Assembly (SOCA) is a transit case deployable communications assemblage that can provide non-SI UHF single-channel SATCOM and HF single-channel communications between liaison elements and the JFSOCC.

e. The JFSOCC normally communicates with the Ranger Regiment as a separate component using a mix of SHF TACSAT, UHF TACSAT, and HF multichannel systems. The Ranger Regiment employs UHF TACSAT and VHF FM systems for internal communications.

Figure VII-2. National Deployed ARSOF C4 Systems

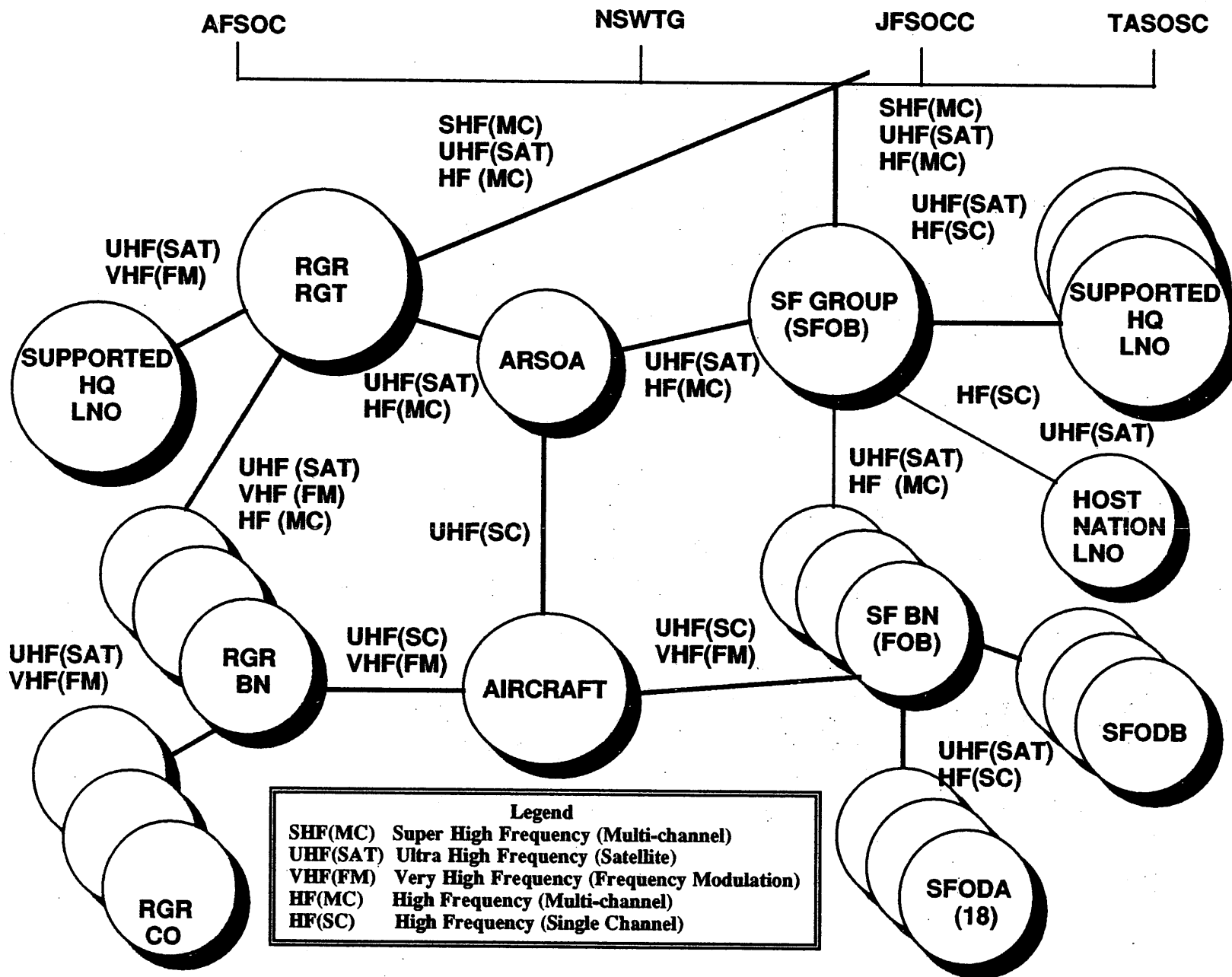

6. NSWTG C4 Systems. Figure VII-3 depicts baseline C4 systems for a notional deployed NSWTG.

a. The JFSOCC-NSWTG link employs a mix of SHF multichannel, HF multichannel and UHF single-channel TACSAT systems.

b. The NSWTG-NSWTU link uses UHF single-channel TACSAT and HF single-channel systems.

c. The Navy NSW base station communications package (TSC-126) provides the basic communications required by an NSWTG for connectivity to Navy units. It is contained in a towed ground mobile van. The Navy Task Unit Van is a smaller communications package that is contained in a van and deployed to support a NSWTU or provide a forward relay for SEAL element communications.

d. SEAL platoons communicate with their higher headquarters using UHF (single-channel) TACSAT and HF (medium-power) systems.

e. The Navy also has two C4 liaison packages that can each be configured into two small suitcases. Both packages provide secure voice and message capability over HF and UHF (single-channel) TACSAT systems.

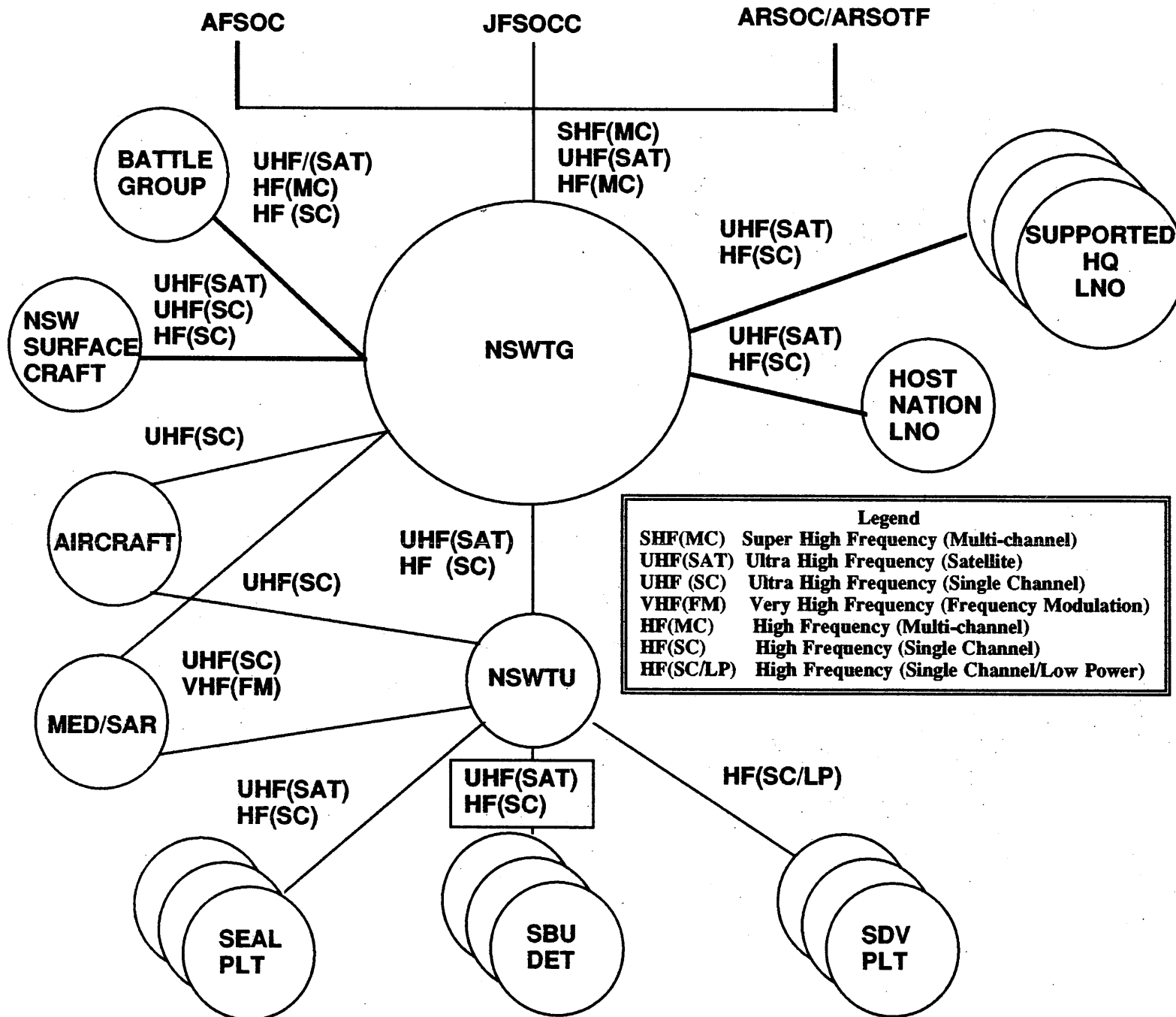

Figure VII-3. National Deployed NSWTG C4 Systems

VII-7

7. AFSOC C4 Systems. Figure VII-4 depicts baseline C4 systems for a notional deployed AFSOC.

a. The JFSOCC-AFSOC link employs a mix of HF multichannel, SHF multichannel, and UHF (single-channel) TACSAT systems.

b. AFSOC-AFSOD and the AFSOD-AFSOE links employ both UHF (single-channel) TACSAT and HF single-channel systems.

c. The AFSOC employs UHF W/B-N/B TACSAT voice/data and HF voice systems to provide dedicated communications links with its home station.

d. The special operations communication package (SOCP) is a lightweight, quick-response, palletized suite of communications equipment, including HF, UHF/VHF line-of-sight systems, UHF single-channel TACSAT, and switchboard. This system provides deployed AFSOF with instant communications support on arrival and limited enroute communications support.

e. The AFSOC, AFSOD, and AFSOE all employ UHF single-channel TACSAT, HF (low- or medium-power) and UHF/VHF line-of-sight systems to communicate with SOF aircraft and ground teams.

f. The Air Force also has a suitcase and rucksack liaison package with a limited UHF, HF voice/data and STU-III voice data capability.

g. Special tactics teams provide AFSOF commanders with a tactically employable ground-to-ground C4 capability. These teams may be employed with UHF single-channel TACSAT; low-power HF and UHF/VHF line-of-sight systems, ground-to-ground VHF/FM systems, HAVE QUICK II, and data encryption equipment.

8. JFSOCC C4 Systems. Figures VII-5 through VII-7 depict baseline C4 systems for three notional JFSOCC configurations. Each configuration would be appropriate for a particular phase of peacetime activities, contingency operation, or war. The JFSOCC normally plans and deploys C4 support in three incremental phases. Each phase is discussed below.

a. Phase ALPHA. This phase (see Figure VII-5) supports C4 requirements during peacetime activities and during crisis situations or incidents where the larger scale commitment of US military forces is anticipated. ALPHA C4 support fits crises such as the 1989 Philippine coup attempt and the 1987 Operation SAFE PASSAGE in the

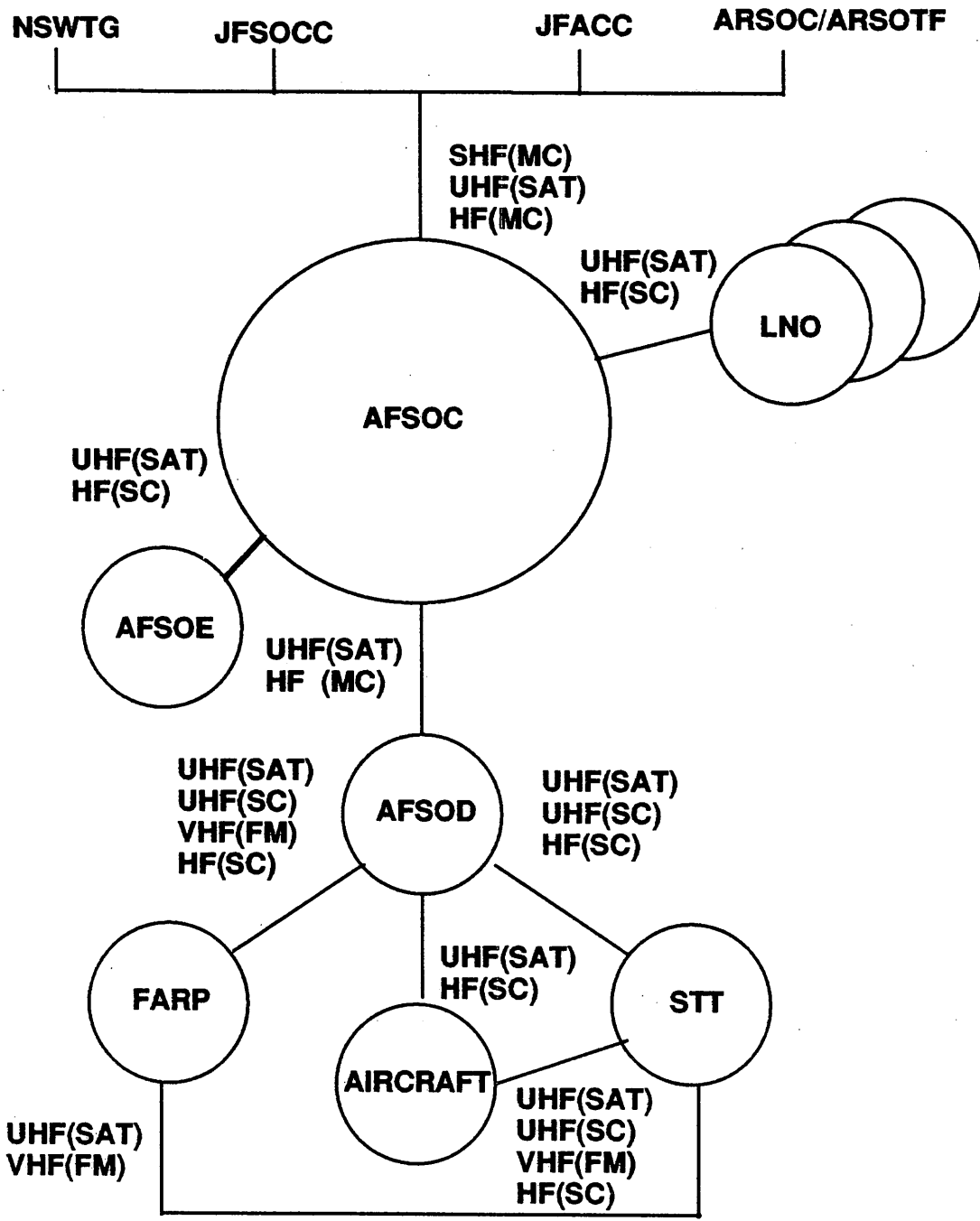

Legend	
SHF(MC)	Super High Frequency (Multi-channel)
UHF(SAT)	Ultra High Frequency (Satellite)
UHF (SC)	Ultra High Frequency (Single Channel)
VHF(FM)	Very High Frequency (Frequency Modulation)
HF(MC)	High Frequency (Multi-channel)
HF(SC)	High Frequency (Single Channel)
HF(SC/LP)	High Frequency (Single Channel/Low Power)

Figure VII-4. Notional Deployed AFSOC C4 Systems

Arabian Gulf, where minimum C4 systems were required for immediate deployment of a JSOTF command post.

(1) Phase ALPHA C4 support provides connectivity via man-portable UHF TACSAT and HF single-channel radios between the JSOTF, supported JFC, theater intelligence architecture (using STICS), appropriate US embassy, and deployed SOF components.

(2) C4 support starts with the normal daily peacetime SOC communications capabilities--AUTODIN, DSN, and garrison communications will suffice in many instances. As a crisis develops, COMSOC may deploy a liaison or assessment element with limited communications capability (usually one or two UHF TACSAT terminals with voice and data input). The communications planning during this phase is limited to the requirement for one or two nets. Imagery may be passed as data and transmitted via personal computer. COMSOC will require augmentation by theater signal assets during a crisis.

b. Phase BRAVO. This phase (see Figure VII-6) supports operations by a fully deployed JSOTF in a short-duration contingency operation (1989 Operation JUST CAUSE in Panama, for example). Phase BRAVO C4 support provides a more robust C4 network of SHF or HF multichannel and UHF line-of-sight communications systems in addition to man-portable UHF TACSAT and HF single-channel radios. The JSOTF will require augmentation by the JCSE, 112th Signal Battalion, or theater signal assets.

c. Phase CHARLIE. This phase (see Figure VII-7) supports sustained military operations during a war. It is therefore the most robust of the C4 configurations. This phase involves employment of a full mix of multichannel and single-channel C4 systems. It may require further access to, or augmentation by, other theater and national signal assets.

9. Communications Planning Considerations. The SOJ6 needs the following specific information to adequately determine communications requirements:

a. Forces and Task Organizations. The SOJ6 needs to know what forces are in the region, what additional forces will be deployed, and what task organizations are existing or will be established. This information is the basis for determining communications connectivity requirements.

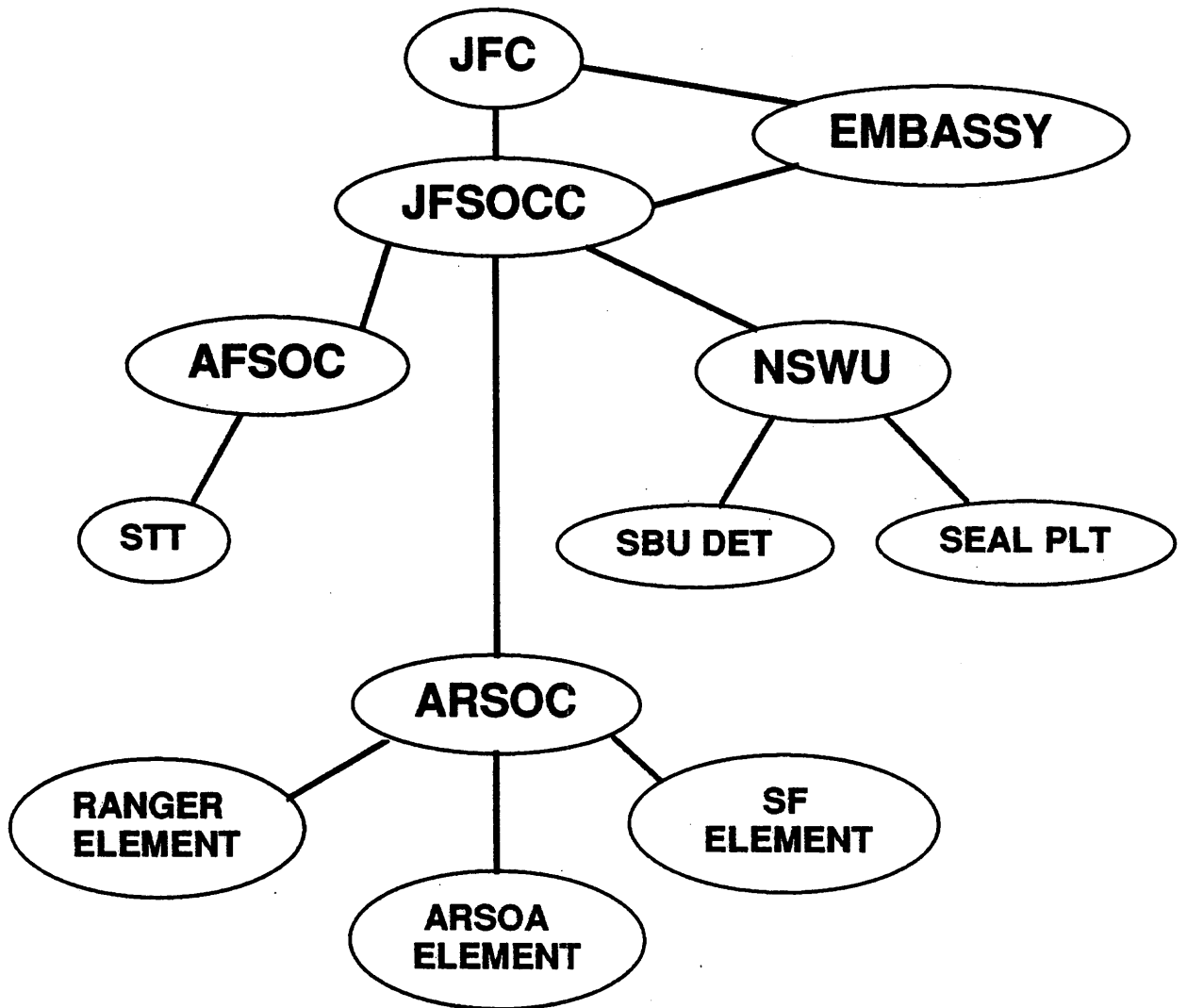

Figure VII-5. Phase ALPHA C4 Support



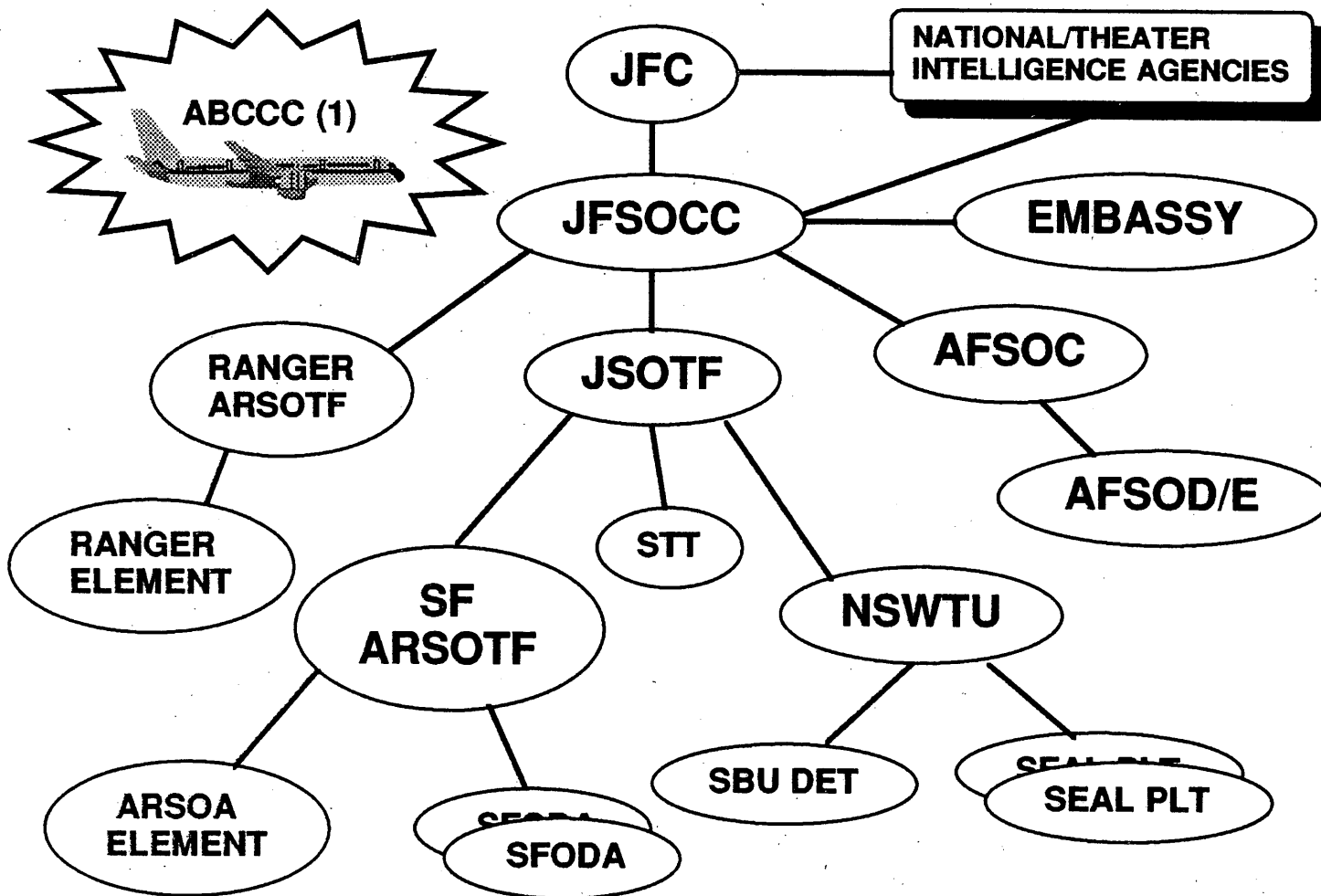

Figure VII-6. Phase BRAVO C4 Support



- b. Radio Nets. The SOJ6 must determine radio net connectivity requirements based upon which JFSOCC and component radio nets are to be activated. The SOJ6 must also determine who the subscribers are and what media, with what type of equipment, will be supporting a subscriber on a net.
- c. Networks and Circuits. The SOJ6 must distinguish between DCS and non-DOD networks and determine if there are commercial, HN military and/or civilian networks that are required to satisfy connectivity requirements.
- d. Communications Equipment. With accurate information about communications equipment, the SOJ6 can build interoperability into the C4 system. The SOJ6 needs technical information on the equipment, its availability, and a list of systems that are interoperable. Automated planning tools are helpful in this effort.
- e. JCEOI. Theater combatant commanders develop contingency JCEOIs to support joint operations. These are finalized and distributed when required. Call signs and frequencies are also coordinated with component staffs. USCINCSOC develops, maintains, and disseminates standard contingency JCEOI systems. These systems support joint operations worldwide, use established joint frequency allocation, and are not oriented toward a specific theater. When necessary, the JFSOCC SOJ6 may tailor or create a JCEOI to support contingency requirements. Whenever possible, JCEOI information should be compiled using an automated system. As a minimum, call signs, radio net frequencies, cryptomaterial and time of changes are needed to establish radio nets.
- f. Points of Contact. In addition to names and phone numbers of key individuals, the SOJ6 should provide telephone directories and routing indicators for the JFSOCC headquarters and all its component headquarters and liaison elements.

## CHAPTER VIII

## LOGISTIC SUPPORT OF SPECIAL OPERATIONS

1. General. This chapter provides guidance for the logistic support of SO, including common and SO-peculiar supply, maintenance, transportation, facilities, and services. Health service support and personnel functions are addressed in Appendixes O and P.

2. Logistic Policies

a. Service Support. Per Joint Pubs 0-2 and 3-05, the logistic support of SOF components is a Service responsibility except where otherwise provided for by servicing agreements or other directives.

b. Joint Support. SO require joint logistic planning and execution. When a theater Service component cannot satisfy its SOF support requirements, the theater combatant commander will determine if another Service component can satisfy the requirements through common, cross-, or joint servicing arrangements. Joint logistic arrangements may also be used when more effective than normal Service support. SOF often require nonstandard arrangements when operating in geographic areas separated from normal theater Service support infrastructures (i.e., theater flanks and undeveloped areas of operation).

c. Readiness. SO may be conducted on short notice and usually in advance of general mobilization. The JFSOCC ensures that logistic units are designated to support SOF for all approved OPLANS and CONPLANS. This establishes recurring support relationships that the JFSOCC will incorporate into theater exercises.

d. SO-Peculiar Support. SO-peculiar support is defined as those items and services required for SO missions that have no broad conventional requirement. USCINCSOC provides this support to deployed SOF through USSOCOM Service component logistic infrastructures.

(1) USCINCSOC Responsibilities. With respect to SO-peculiar support, USCINCSOC is responsible for:

- (a) Validating SO-peculiar theater requirements.
- (b) Identifying SO-peculiar items and services to meet theater requirements.

(c) Developing, establishing, acquiring, and supporting SO-peculiar items of equipment.

(d) Acquiring SO-peculiar materials, supplies, and services.

(e) Establishing procedures to contract for SO-peculiar items and services.

(2) Theater Combatant Commander Responsibilities.

The theater combatant commander identifies requirements for SO-peculiar items and services and forwards them to USCINCSOC if the requirement exceeds theater capabilities. The theater combatant commander normally delegates this authority to the COMSOC. The identification of SO-peculiar requirements is an operational decision that is tied to the supported commander's concept of operation and mission requirements (resourcing, sourcing, and delivery of SO-peculiar equipment are logistic functions). To ensure the process is effective, theater procedures should be clearly stated. This process requires close coordination at all levels between the respective operations and logistic staffs. USCINCSOC will monitor the process to assist and expedite it when required. There are two basic procedures for identifying and validating SO-peculiar equipment:

(a) Predeployment. Requests for additional or above-authorization equipment fills will be justified on the basis of the supported commander's missions and operational requirements, and will be processed through Service channels.

(b) Postdeployment. Requests for SO-peculiar items flow through the SOJ4 to the theater combatant commander, unless SO-peculiar validation authority is delegated to the COMSOC. Readily available equipment will first be sourced through theater Service channels. For equipment requiring procurement action, SO-peculiar requirements will be passed to USSOCOM. Generally, USSOCOM will take procurement action based on production availability, lead time required, and availability of potential substitutes to meet identified mission requirements.

3. Responsibilities. The SOC headquarters will normally be supported by a theater Service component. Other joint SOF

elements, such as a JSOTF headquarters, will normally be supported through cross-servicing arrangements, command arrangement agreements, and/or inter-Service support agreements. Theater SOF component headquarters (i.e., ARSOTFs, AFSOCs, and NSWTGs) will be supported by their respective theater Service component. Specific responsibilities follow:

a. The Theater Combatant Commander. The theater combatant commander exercises logistic directive authority to ensure accomplishment of joint SO missions. He assigns executive agent responsibilities to a theater Service component commander when single-Service sourcing or functional management enhances economy of resources and asset control. Responsibility for single-Service support usually is assigned to the dominant Service user.

b. Theater Service Component Commanders. Theater Service component commanders support their assigned and attached SOF logistically and execute cross-, common, or joint servicing arrangements in support of SOF in accordance with command arrangement agreements and inter-Service support agreements or as directed by the theater combatant commander.

c. Theater JFSOCC. The theater JFSOCC assigns personnel to joint logistic regulatory boards, offices, or agencies as directed by the theater combatant commander, monitors the logistic support of subordinate SOF component commanders, and validates SO-peculiar logistic requirements when that authority has been delegated to him.

4. Logistic Planning. The SOJ4 is responsible for preparation of the logistic annex to all SO plans and orders. The logistic annex should, at a minimum, outline logistic policies, tasks, procedures, and servicing arrangements for the support of assigned and attached forces. It must be thoroughly coordinated with the theater combatant command and theater Service components to ensure plan feasibility. The SOJ4 should consider the following:

a. Resupply as an Operational Mission. Upon initiation of tactical operations, logistic planning becomes an ongoing process for the JFSOCC and SOF component commanders. There is an important distinction between SOF and conventional resupply. When SOF are operating from forward bases or in remote or denied areas, resupply and medical evacuation are usually planned and executed as operational missions, as opposed to logistic responsibilities. Consequently, detailed logistic and operational planning is required to assure emergency

resupply and evacuation operations for employed SOF. Resupply planning is the responsibility of the JFSOCC, who assesses existing supply levels and available delivery platforms. Should deficiencies occur, the JFSOCC should elevate logistic needs to the JFC or the theater logistic staff, as appropriate, for resolution.

b. Planning Factors. Theater-approved sustainment planning factors will normally be provided for logistic planning.

c. Organic Supply. SOF will plan to deploy with their unit basic loads and at least 30 days of accompanying supplies, unless otherwise directed by the supported commander.

d. Logistic Planning Checklist. A SOF logistic planning checklist is provided in Appendix J.

5. Logistic Functions. Agility, flexibility, and avoidance of redundant supply systems must be emphasized in order to maximize support to operational elements while minimizing overhead. Planning must consider joint support arrangements to streamline the support system from the wholesale support base to the point of employment. Normally, resupply is theater-based, but, when required, emergency supplies may be routed from CONUS-based SOF Service component commands. The support and sustainment of SOF require in-place inter-Service support agreements, avoidance of ad-hoc support arrangements, and an efficient and effective transportation system. Procedures for SO-peculiar logistic functions are discussed below.

a. Host-Nation and Foreign-Nation Support. While host-nation or foreign-nation support is encouraged for common support items, the use of HNS and FNS must be carefully weighed against OPSEC and mission requirements. Local purchases through HNS or FNS will be accomplished in accordance with established Service and theater procedures.

b. Sources of Supply. When available, theater war reserve stocks, operational project stocks, readiness spares packages, and other preplanned deployment packages will be the primary sources of SOF supply until ALOCs and HNS or FNS are established. The theater will be the principal source of sustaining supplies; however, depending on geographic and operational circumstances, CONUS may be the source of sustaining supplies. Theater support structure (preferably via ALOCs) will normally provide emergency and high priority supplies, to include SO-peculiar, mission-critical, and low-density items as

coordinated through Service supply control centers and transportation activities.

c. Petroleum, Oils, and Lubricants

(1) Maximum use will be made of in-country military and commercial bulk fuel stocks for ground and aviation refueling requirements. HNS must be prearranged through in-country contractual agreements with the theater Joint Petroleum Office or Defense Fuel Region supporting the area of operations.

(2) The combatant command manages POL through the JPO. The JPO consolidates theater Service component long-range requirements and adjudicates distribution priorities between components. Normally, the Army component commander is responsible for inland petroleum distribution to all land-based forces. This includes wholesale receipt, storage, and distribution of bulk fuels, packaged POL, and, when necessary, the operation and maintenance of pipelines and other facilities.

(3) Normally, the theater Air Force component commander will provide routine and emergency airlift of bulk and packaged POL in the joint operations area until surface resupply systems are established.

(4) Fuel operations supporting SOF bases will be assigned to a single Service to minimize redundant fuel support requirements. For example, when operating a SOF base on a USAF airfield, responsibility for all fuel operations would normally be a USAF responsibility.

d. Ammunition

(1) The JFSOCC, through the SOJ4, will coordinate ammunition support for assigned SOF through the Service component best able to provide it. For example, the Army component may be better situated than the Navy component to provide small arms ammunition to NAVSOF.

(2) The JFSOCC, through the SOC J4, coordinates security, acquisition, and storage of ammunition through the appropriate theater Service component. The SOJ4 monitors component SO-peculiar ammunition status for economy of resources, mission taskings, and apportionment of critical resources.



(3) The JFSOCC, through the SOC J4, coordinates inter-Service support arrangements for acquisition, storage, and distribution of ammunition whenever possible. Service line haul, normally a theater Army responsibility, is the primary mode for intratheater movement of ammunition, with air movement of ammunition usually restricted to emergencies.

6. Logistic Reporting. Logistic reporting for SOF is defined in the appropriate theater directives or USSOCOM SOP.

7. Logistic Communications. The SOJ4 must identify communications requirements to support SOF logistic functions to the SOJ6 for acquisition and installation. The logistics communications net connects with the SOC C3 system. Additionally, theater regulatory boards, centers, and offices may require communications links outside those normally provided to the COMSOC. Radio communications may be required where landline or satellite telephone circuitry is inadequate or unavailable.

8. SO Bases and Facilities. SOF component commanders will identify facilities and construction requirements to support their operations. They will submit these requirements through their Service components. Construction in response to time-sensitive missions requires expedient work. Deviations from standards must be approved by the JFSOCC and the theater combatant commander. SOF normally operate from one or more main operations bases (MOBs) and a variable number of forward operations bases (FOBs) and advanced operations bases (AOBs).

a. An MOB is a base established by a JFSOCC or a subordinate SOF component commander in friendly territory to provide sustained command and control, administration, and logistic support to SO activities in designated areas. The MOB is normally the location of an ARSOTF, AFSOC, or NSWTG. The SF Group calls its MOB the Special Forces operations base. The AFSOC calls its MOB the Air Force special operations base.

b. An FOB is a base usually located in friendly territory or afloat that is established to extend the command and control or communications of a MOB or to provide support for training and tactical operations. The FOB may be established for temporary or longer duration operations and may include an airfield or an unimproved airstrip, an anchorage, or a pier. The FOB is normally the location of a SOF battalion, squadron, or task unit controlled and/or supported by the SOF component commander at a MOB.

c. An AOB is a small temporary base established near or within a JSOA to command, control, and/or support training or tactical operations. Facilities are normally austere. The base may be ashore or afloat. If ashore, it may include an airfield or unimproved airstrip, a pier, or an anchorage. An AOB is normally the location of a SOF company or smaller element controlled and/or supported by an MOB or FOB.

9. Combined or Indigenous SO Logistic Support. US logistic systems normally support US SOF conducting combined SO with allied SOF or conventional forces. Indigenous forces involved in US-sponsored or US-supported SO will normally provide the major portion of their own logistic support requirements. When authorized by law and approved by the theater combatant commander, however, US SOF may furnish supplies, services, and medical support to allied forces.

10. ARSOF Logistic Support. The support and sustainment of ARSOF involves a combination of theater Army, nonstandard, and joint support.

a. Theater Army Support. The TA provides logistic support to ARSOF on an area or unit basis. The theater army commander should designate specific Army support units to provide ARSOF support to ensure habitual support relationships are established and exercised. During contingencies and operations in which the theater support base is not established, ARSOF will initially rely on unit-level support with augmentation from the 528th Special Operations Support Battalion.

b. Logistic Augmentation to ARSOF. The extent of logistic augmentation varies by mission, operational circumstance, and the available theater support infrastructure. The organizational logistic capabilities of ARSOF vary widely. While most ARSOF units possess limited unit-level logistic capabilities, Ranger units require extensive logistic augmentation.

c. Theater Army Special Operations Support Command. The TASOSC is a subordinate functional command of the theater Army. The TASOSC is responsible for planning and coordinating the support and sustainment of theater ARSOF. The TASOSC does not normally provide direct support to ARSOF and has no organic support infrastructure. If Army units are assigned or attached to the TASOSC to support ARSOF on a dedicated basis, the TASOSC plans, coordinates, directs, and supervises the activities of these units.

11. AFSOF Logistic Support. The host base provides AFSOF common support and sustainment (i.e., facilities, supplies, services, security). USSOCOM provides AFSOF-peculiar support requirements (i.e., maintenance, supplies).

a. AFSOF maintenance support emphasizes a remove-and-replace concept through a combination of high priority mission support kits, readiness spares packages, and maintenance equipment to troubleshoot to the line replacement unit or component level (i.e., limited intermediate level support). AFSOF units normally tailor their contingency support packages to accommodate the mission options for self-deployment, limited airlift deployments, and, when applicable, shipboard operations.

b. Intermediate level maintenance support may be deployed to collocate with AFSOF or be centrally located to support theater operations. The AFSOC LRC receives requests for unavailable aircraft mission-capable parts and coordinates their sourcing and delivery. The Air Force Service component provides all other support.

12. NAVSOF Logistic Support. Deployed NAVSOF are supported and sustained in the following manner:

a. When supporting fleet operations, NAVSOF will be supported by the Battle Group or Amphibious Ready Group Commander using standard Navy support channels, with NAVSOF-peculiar support provided by unit deployment packages.

b. When NAVSOF are operating ashore, common and NAVSOF-peculiar support is the responsibility of the theater Navy component commander. When Navy support is infeasible, the JFSOCC will coordinate inter-Service support from Army or Air Force SOF or from theater assets. Inter-Service support agreements should be coordinated in advance of operational deployments and based on concise statements of requirements.

c. Forward-based NSWUs provide a logistic conduit for other deployed NAVSOF.

APPENDIX A

REFERENCES

1. Purpose and Scope. This appendix is a guide to SOF-related joint publications and Service guidance. All operational headquarters involved with SOF should have these documents readily available. Publications are listed by title and designation.

2. General. Joint SO doctrine, JTTP, and Service guidance have undergone extensive revision and development since the establishment of USSOCOM. The Joint Publication System provides joint doctrine and JTTP for commanders at all levels. Joint Pub 3-05 provides fundamental doctrine for joint SO. Joint Pubs 3-05.3 and 3-05.5 provide JTTP for operational and tactical SOF commanders. USSOCOM components provide SOF input to their parent Service doctrine and publish detailed Service guidance (manuals, regulations, SOPs, etc.) to SOF units.

3. Joint Publications

- a. 1-01, "Joint Publication System"
- b. 1-02, "DOD Dictionary of Military and Associated Terms"
- c. 1-03.30, "Joint After-Action Reporting System"
- d. 2-0, "Doctrine for Intelligence Support to Joint Operations"
- e. 2-01, "Tactics, Techniques, and Procedures for Intelligence Support to Joint Operations"
- f. 2-01.2, "Joint Doctrine, Tactics, Techniques, and Procedures for Counterintelligence Support for Operations"
- g. 3-0, "Doctrine for Joint Operations"
- h. 3-01.3, "Joint Doctrine for Air Defense from Overseas Land Areas"
- i. 3-05, "Doctrine for Joint Special Operations"
- j. 3-05.5, "Joint Special Operations Targeting and Mission Planning Procedures"
- k. 3-07, "Doctrine for Joint Operations in Low Intensity Conflict"

l. 3-07.1, "Joint Tactics, Techniques and Procedures for Foreign Internal Defense"

m. 3-52, "Doctrine for Joint Airspace Control in the Combat Zone"

n. 3-53, "Doctrine for Joint Psychological Operations"

o. 3-56.1, "Command and Control of Joint Air Operations"

p. 3-56.24, "Tactical Command and Control Planning Guidance and Procedures for Joint Operations, Joint Interface Operational Procedures (JIOP)"

q. 3-57, "Doctrine for Joint Civil Affairs"

r. 4-0, "Doctrine for Logistic Support of Joint Operations"

s. 5-0, "Doctrine for Planning Joint Operations"

t. 5-00.1, "Joint Tactics, Techniques, and Procedures for Campaign Planning"

u. 5-03.1, "Joint Operation Planning and Execution System, Volume I, Planning Policies and Procedures"

v. 5-03.2, "Joint Operation Planning and Execution System, Volume II, Planning and Execution Formats and Guidance"

w. 6-0, "Doctrine for Command, Control and Communications Systems Support to Joint Operations"

#### 4. Service Guidance

a. Army. The following Army publications apply to ARSOF:

(1) FM 1-108, "Special Operations Aviation"

(2) FM 7-85, "Ranger Unit Operations"

(3) FM 31-19, "SF Military Freefall"

(4) FM 31-20, "Special Forces Operations"

(5) FM 31-20-1, "Special Forces Tactics, Techniques, and Procedures"

(6) FM 31-20-2, "Special Forces Unconventional Warfare"

- (7) FM 31-20-3, "Special Forces Foreign Internal Defense"
- (8) FM 31-20-4, "Special Forces Direct Action"
- (9) FM 31-20-5, "Special Forces Special Reconnaissance"
- (10) FM 31-20-6 (S), "Special Forces Counterterrorism (U)"
- (11) FM 31-24, "Special Forces Air Operations"
- (12) FM 31-25, "Special Forces Waterborne Operations"
- (13) FM 31-26, "Special Forces Advanced Operations Techniques"
- (14) FM 31-27, "Pack Animal Operations"
- (15) FM 33-1, "Psychological Operations"
- (16) FM 33-5, "Psychological Operations Tactics, Techniques, and Procedures"
- (17) FM 41-10, "Army Civil Affairs"
- (18) FM 41-11, "Civil Affairs Tactics, Techniques, and Procedures"
- (19) FM 90-31, "Counterinsurgency Operations"
- (20) FM 100-5, "Operations"
- (21) FM 100-20, "Low Intensity Conflict"
- (22) FM 100-25, "Doctrine for Army Special Operations Forces"

b. Navy. The following Navy publications apply to NAVSOF:

- (1) NWP 15, "Naval Special Warfare (U)"
- (2) NWP 15-1, "SEAL Teams in Naval Special Warfare (U)"
- (3) NWP 15-2, "Special Boat Squadrons in Naval Special Warfare (U)"

- (4) NWP 15-4, "SEAL Delivery Vehicle Teams in Naval Special Warfare (U)"
- (5) NWP 22-4, "Underwater Demolition Teams in Amphibious Operations (U)"
- (6) NWP 79-0-4, "Submarine Special Operations Manual (U)"
- (7) NWP 90, "Naval Special Warfare (U)" (in development to replace all NWP 15-series publications)
- (8) OPNAVINST 1412.7, "NSW Officer Qualification and Designation."
- (9) COMNAVSPECWARCOM TACMEMO XL-2080-5-89, "NSW Laser/Beacon Operations"
- (10) COMNAVSPECWARCOM TACMEMO XL-0080-7-89, "NSW Special Reconnaissance Operations and Reporting"
- (11) COMNAVSPECWARCOM TACMEMO XL-2080-4-89, "Dry Deck Shelter"
- (12) COMNAVSPECWARCOM TACMEMO XL-0058-3-89, "SDV/Beach Feasibility Study"
- (13) COMNAVSPECWARCOM TACMEMO XL-2080-2-89, "NSW Combatant Craft"
- (14) COMNAVSPECWARCOM TACMEMO XL-0058-10-90, "NSW Harbor Penetration/Ship Attack"
- (15) COMNAVSPECWARCOM TACMEMO XL-0080-1-90, "NSW Stand-off Weapons Tactical Employment Guide and Lessons Learned"
- (16) COMNAVSPECWARCOMINST 3120.1, "Safety Regulations and Operations Guidelines for Combat Rubber Raiding Craft (CRRC)"
- (17) COMNAVSPECWARCOM "Naval Special Warfare Information Handbook"

c. AFSOF. The following Air Force publications apply to AFSOF:

- (1) AFM 2-1, "Theater Aerospace Warfare"
- (2) AFM 2-10, "Aerospace Operational Doctrine, Special Operations"

- (3) AFM 2-11, "Aerospace Operational Doctrine, Foreign Internal Defense"
- (4) AFM 2-12, "Airspace Control in a Combat Zone"
- (5) AFR 64-4, "Search and Rescue Survival Training"
- (6) AFSOCM 3-1, "Tactical Employment"
- (7) AFSOCR 51-2, "Special Tactics Training"
- (8) AFSOCR 55-3, Vol I, "AFSOC Command and Control Responsibilities and Procedures"
- (9) AFSOCR 55-3, Vol II (S), "AFSOC Emergency Action Procedures (U)"
- (10) AFSOCR 55-18, "Helicopter Operations"
- (11) AFSOCR 55-130, "C-130 Operations"
- (12) AFSOCR 55-160, "Assault Zone Operations"
- (13) AFSOCR 160-2, "Pararescue Medical Training"
- (14) Multi-Command Manual 3-1, "Tactical Employment"

d. Marine Corps

- (1) Marine Corps Capabilities Plan
- (2) MCO 31200.8A, "Policy for the Organization of Fleet Marine Forces for Combat"



(INTENTIONALLY BLANK)

## APPENDIX B

## JFSOCC (SOC) INTERNAL ORGANIZATION

1. Purpose and Scope. This appendix provides a model of how JFSOCCs may organize their headquarters to perform those functions described in Chapter III. It discusses the duties and responsibilities of the JFSOCC command group, staff directorates, and special and personal staffs. The actual circumstances facing the JFSOCC may warrant modification of this model.
2. JFSOCC Command Group. The command group normally consists of the commander, deputy commander, chief of staff, and senior enlisted adviser.
  - a. The commander exercises OPCON of assigned and attached forces and serves as the JFC's principal SO adviser. The commander may also be dual-hatted as the principal SO staff officer on the JFC staff.
  - b. The deputy commander is the principal assistant to the commander, performs duties as directed, and assumes the duties of the commander in his absence.
  - c. The chief of staff directs the daily activities of the JFSOCC staff; supervises the preparation of staff estimates, plans, and orders; and coordinates the activities of liaison elements. If there is no chief of staff assigned, the deputy commander may also perform these duties.
  - d. The senior enlisted adviser advises the commander on JFSOCC plans, policies, and programs as they affect the enlisted personnel of the JFSOCC staff and assigned and attached forces. He performs additional duties as directed by the commander.
3. Typical JFSOCC Staff Organization. A typical JFSOCC staff is organized to perform standard joint staff functions (see Figure B-1). Ideally, each JFC should have adequate resources to properly staff the JFSOCC. Unfortunately, resource limitations may preclude adequate manning. If insufficient manpower is available to fill all staff positions, the JFSOCC must arrange for external support of JFSOCC requirements (for example, JFC J6 designates a staff officer to be a part-time SOJ6) or extend his resources to cover all required functions (for example, a combined SOJ3/5).
4. SOJ1 (Manpower and Personnel). The SOJ1 provides administrative and personnel service support to the JFSOCC staff. The SOJ1 is responsible for the joint manpower

program and other staff manning actions. The SOJ1 must also monitor and report to the JFSOCC the personnel readiness assigned, allocated, and apportioned forces. Specific duties include (see Appendix P for further discussion):

- a. Maintain a current personnel estimate.
  - b. Monitor and report personnel status and casualties.
  - c. Develop personnel policies and plans.
  - d. Prepare personnel portions of plans and orders.
  - e. Determine replacement personnel policies, requirements, and allocations.
  - f. Coordinate with the SOJ4 to assure adequate support of replacements and augmentees (particularly critical to Reserve components).
  - g. Coordinate and process personnel actions (individual replacements, orders processing, efficiency reports, awards and decorations, leave forms, etc.) for JFSOCC headquarters.
  - h. Coordinate with the JFSOCC medical planner and JFC J1 to establish medical evacuation policy and procedures for SOF within the joint area.
  - i. Arrange for required JFSOCC staff augmentation.
  - j. Serve as JFSOCC focal point for Reserve component personnel issues, including management of the JFSOCC individual mobilization augmentee program.
  - k. Monitor the provision of personnel services to SOF units by their Service components or other designated sources.
  - l. Plan, coordinate, and manage morale and welfare activities for the JFSOCC.
  - m. Establish and operate the JFSOCC message and distribution center and provide postal services to the JFSOCC headquarters.
5. SOJ2 (Intelligence). The SOJ2 is the focal point for all-source intelligence and counterintelligence support for attached and assigned forces and provides JFC access to the USSOCOM intelligence network. The SOJ2 supervises the production and maintenance of target intelligence packages (see Joint Pub 3-05.3) and provides intelligence estimates,

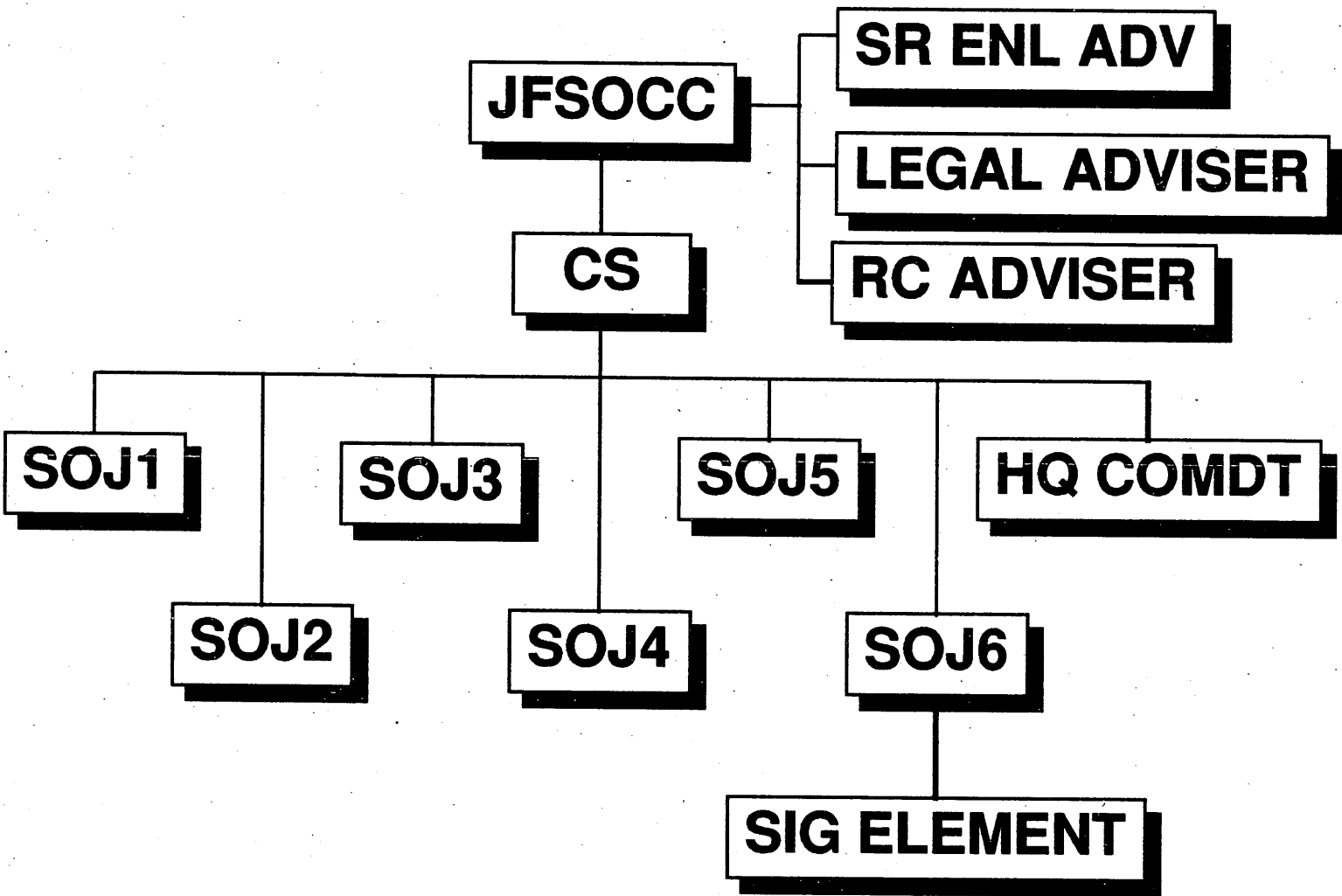

Figure B-1. Typical JFSOCC Staff Organization

briefings, and debriefings as required. Specific duties include:

- a. Maintain a current intelligence estimate.
- b. Develop intelligence and counterintelligence portions of plans and orders, EEI, collection plans, access rosters, and intelligence summaries.
- c. Review, validate, and coordinate all-source collection requirements for the JFSOCC staff and subordinate units and perform collection management functions for the JFSOCC staff.
- d. Provide JFC intelligence architecture with SOF intelligence requirements.
- e. Direct and manage the JFSOCC targeting effort, including management of the target intelligence production program and maintenance of the targeting intelligence data base.
- f. Supervise and coordinate security and counterintelligence activities, including source administration and review of subordinate unit plans and activities.
- g. Support SOJ3 OPSEC and deception planning.
- h. Maintain liaison with appropriate national and theater intelligence agencies.
- i. Support JFSOCC evasion and escape activities.
- j. Establish and operate the JFSOCC sensitive compartmented information facility (SCIF).
- k. Coordinate mapping, charting, and geodesy support.
- l. Coordinate weather and oceanography support.

6. SOJ3 (Operations). The SOJ3 is responsible for the operations, organization, and training of assigned and attached forces. The SOJ3 plans, coordinates, and directs the deployment and employment of joint SOF under the OPCON of the JFSOCC. In peacetime, the SOJ3 plans, coordinates, and directs joint and combined SOF exercises and training. Additionally, the SOJ3 must monitor (through USSOCOM) apportioned forces' readiness to accomplish JFC tasks. Specific duties include:

- a. Maintain a current operations estimate.
- b. Maintain JFSOCC SOP.
- c. Prepare operations plans and orders (including tactical movement orders).
- d. Review plans and orders of subordinate units.
- e. Recommend approval or disapproval of subordinate unit mission concepts.
- f. Recommend priorities for operational support.
- g. Recommend composition and tasking of subordinate elements (task organization).
- h. Coordinate use of airspace.
- i. Deconflict SO with other operations.
- j. Recommend JSOA boundaries and other SO control measures.
- k. Coordinate for staging areas.
- l. Prepare operational records and reports.
- m. Establish and enforce OPSEC procedures.
- n. Plan and coordinate cover and deception operations.
- o. Recommend appropriate SO to JFSOCC.
- p. Administer JFSOCC focal point systems and special access programs.
- q. Provide or arrange for liaison elements to the JFC staff, JFACC (when established) and other component staffs, and supported organizations as directed by the JFC.
- r. Plan, coordinate, and direct E&E activities and other sensitive special operations controlled by the JFSOCC.
- s. Develop, coordinate, and implement SOF training and exercise programs to prepare for wartime missions and support peacetime objectives and strategy.
- t. Establish and operate the joint operations center (JOC) when directed.

7. SOJ4 (Logistics). The SOJ4 exercises staff responsibility for ensuring the adequate logistic support of all forces assigned or attached to the JFSOCC. Logistic support is primarily a Service responsibility unless inter-Service support agreements are in effect. The routine sustainment of assigned and attached forces is therefore transparent to the SOJ4. However, the SOJ4 is responsible for recommending logistic priorities to the JFSOCC, monitoring Service support to SOF, arranging inter-Service support agreements when Service support is inadequate, and coordinating SO-peculiar logistic support from USSOCOM. Specific duties include:

- a. Maintain a current logistic estimate.
- b. Develop logistic plans and recommend logistic support arrangements for assigned, attached, or apportioned forces.
- c. Coordinate SO-peculiar support for SOF attached to other component commanders.
- d. Coordinate inter-Service support for subordinate forces as required.
- e. Review, validate, and consolidate statements of requirements from assigned, attached, or apportioned forces.
- f. Monitor the provision of logistic support to assigned and attached forces by their Service components or other designated sources.
- g. Ensure accountability of supplies and equipment.
- h. Recommend controlled supply rates of critical resources.
- i. Recommend JFC stock levels for SOF support.
- j. Coordinate the establishment and maintenance of operational project stocks.
- k. Support operational resupply of deployed SOF.
- l. In coordination with the SOJ3, establish clandestine support mechanisms (low-visibility deployment, resupply, etc.)
- m. Monitor and report equipment readiness status of assigned, attached, and apportioned forces.

- n. Determine maintenance priorities and coordinate assistance from JFC components and USSOCOM (as the CONUS support base).
- o. Plan, coordinate, and monitor administrative movement of personnel, equipment, and supplies.
- p. Identify and coordinate civil engineering support requirements and monitor the construction and maintenance of facilities and installations for the JFSOCC and assigned or attached forces.
- q. Control and coordinate maintenance of real property.
- r. Coordinate logistic support of JFSOCC headquarters.
- s. Coordinate for contracting and foreign-nation support for assigned, attached, or apportioned forces.
- t. Develop plans and programs for the medical support of the JFSOCC staff and its assigned and attached forces, including the medical treatment and evacuation of supported indigenous forces as required.
- u. Prepare JFSOCC program recommendations and budget estimates, manage the JFSOCC budget, and prepare required reports.

8. SOJ5 (Plans and Policy). The SOJ5 prepares the SO portions of JFC campaign, concept, operation, and supporting plans. The SOJ5 participates in the joint targeting process by providing SOF representation on the JFC joint targeting coordination board (JTCCB) and chairing the JFSOCC target panel (see Joint Pub 3-05.5). The SOJ5 projects future SOF requirements for force development and defines JFC requirements that will impact research, development, and acquisition of SO-peculiar equipment. Specific duties include:

- a. Direct the review, analysis, and promulgation of JFSOCC plans, policies, and programs.
- b. Direct and manage the JFSOCC deliberate planning process, including production of operational concepts and operations and concept plans.
- c. Develop SOF TPFDD in conjunction with the SOJ4.
- d. Manage the JFSOCC joint doctrine program.



e. Develop JFSOCC input to the Joint Strategic Planning System (JSPS) and Joint Operations Planning and Execution System (JOPES).

f. Manage the JFSOCC's Worldwide Military Command and Control System (WWMCCS) computer system.

g. Provide JFSOCC representation on the JFC crisis action team.

h. Provide a SOJ5 Plans element to the JOC when established (see Appendix C).

i. Provide the JFC SO staff directorate or division when directed by the JFC.

9. SOJ6 (Communications). The SOJ6 is responsible for communications-electronics and automated data processing (ADP) systems supporting assigned and attached SOF. The SOJ6 has staff responsibility for communications and frequency management, communications planning and execution, and the management and development of electronics and automated information systems. Specific duties include:

a. Design communications architecture to support assigned, attached, or apportioned SOF.

b. Prepare communications plans, orders, and annexes; assist subordinate elements in developing supporting plans.

c. Prepare and maintain JCEOI.

d. Supervise the operation of communications units and facilities directly supporting the JFSOCC.

e. Act as single SOF point of contact for all other communications agencies within and outside of the joint area.

f. Perform frequency management for the JFSOCC and subordinate forces.

g. Establish and manage COMSEC procedures.

h. Ensure communications interoperability and compatibility for all required media between all subordinate units and other appropriate US forces, agencies, or foreign elements.

i. Provide cryptographic support and clandestine communications systems (in coordination with the SOJ2 and SOJ3).

j. Provide information management between the JFSOCC and theater and defense communications systems.

k. Coordinate ADP systems installation, operation, maintenance, and security within the JFSOCC headquarters.

10. Special and Personal Staffs. The composition of the JFSOCC special and personal staffs depend heavily on JFC requirements. These staffs may include (but are not limited to) the staff elements discussed below. These elements may not be permanent elements of the staff. Functions performed by these staff elements may be assigned to other JFSOCC staff sections or other headquarters (consolidation of public affairs functions at the JFC staff level, for example).

a. Headquarters Commandant. The headquarters commandant is responsible to the chief of staff for the movement, internal administration, base operations (including space allocation, billeting, unit supply and maintenance, and food service), and physical security of the JFSOCC headquarters. When no full-time headquarters commandant is assigned, the JFSOCC must divide these functions among the JFSOCC staff and assign one staff officer (normally the SOJ1 or SOJ4) to provide overall staff supervision.

b. Legal Adviser. The legal adviser provides advice to the JFSOCC and staff on matters involving military law, US domestic law, foreign and international law, status of forces agreements, operational law, and rules of engagement. The political sensitivity of many SO dictate that the legal adviser be integrated into mission planning. When this is not required, the legal adviser should review plans for legal implications. See Appendix N for more information on the legal aspects of SO.

c. Public Affairs Officer. Because of the media interest in SO, the JFSOCC should develop thorough and detailed public affairs guidance during the planning phase. As a minimum, this guidance should prescribe the procedures to follow in the event of media query or public disclosure of classified or sensitive information. The JFC may provide public affairs support to the JFSOCC on an area basis or attach a public affairs officer (PAO) to provide dedicated support on a mission basis. The PAO can also establish a command information program for members of the command and their families.

When no full-time PAO is available, the JFSOCC normally assigns these functions to the SOJ1 or SJA.

d. Inspector General. The JFSOCC may be authorized to designate an inspector general (IG), but normally must rely on the assistance of the JFC's IG. When designated, the IG is responsible directly to the JFSOCC for monitoring, evaluating, assessing, and inspecting operational matters and, when directed, any other matter within the scope of the JFSOCC's authority.

e. Comptroller. The comptroller is responsible to the chief of staff for programming, budgeting, and budget execution of all JFSOCC funds, to include special mission funds, intelligence contingency funds, foreign currency operations, and commercial accounts. The comptroller coordinates and exercises technical control over JFSOCC financial policies, plans, and services. The comptroller is frequently a member of the JFC staff (or the supporting Service component staff) who has been designated to manage MFP-11 accounts for the JFC and JFSOCC.

f. PSYOP Staff Officer. The PSYOP staff officer is responsible to the SOJ3 or SOJ5 for integrating PSYOP into JFSOCC estimates, plans, and orders. The psychological effects of SO must be anticipated and included in SO planning and activities. SO plans normally include a PSYOP annex that integrates PSYOP efforts to attain military and political objectives and to support and deconflict tactical cover and deception activities. Advice of a PSYOP staff officer should be available early during SO mission planning to identify requirements and develop solutions. See Appendix L for more information on PSYOP.

g. Civil Affairs Staff Officer. The CA staff officer is responsible to the SOJ4 for planning and coordinating foreign-nation support of the JFSOCC and subordinate forces. The CA staff officer also supports the SOJ3 and SOJ5 by integrating civil-military operations into JFSOCC estimates, plans, and orders. The importance of civil sector support for SO and the effects of SO on civilian populations must be anticipated and included in planning. SO plans will normally include a CA annex. Advice of a CA staff officer should be available early during SO mission planning to identify requirements and develop solutions. See Appendix M for more information on CA.

h. Medical Planner. The medical planner is responsible to the SOJ4 for planning and coordinating health service support of the JFSOCC and its subordinate forces. The complexity of SO medical planning and execution requires full-time attention from a qualified medical planner. Medical considerations can adversely affect tactical SO because of unique mission requirements and the environment within which SOF operate. Nonmedical or non-SOF medical staffs cannot provide the JFSOCC with the same support as a dedicated medical planner. See Appendix O for more information.

i. Security Assistance Staff Officer. Frequent security assistance deployments may cause JFSOCC to establish a security assistance section within the SOJ3 or SOJ5. Normally, the focus of the JFSOCC in security assistance is operational vice logistic. The section should review SO security assistance activities within the context of long-term JFC objectives and ensure that they are in consonance with the JFC strategy.

j. Reserve Component Adviser. The Reserve component (RC) adviser advises the JFSOCC on the use of apportioned RC units and individual mobilization augmentees (IMAs) to meet JFSOCC requirements. The RC adviser then coordinates with the JFSOCC, JFC, and Service component staffs to obtain RC assets and integrate them into JFSOCC plans, exercises, and current operations.

11. Rear Detachment. When the theater JFSOCC establishes a JSOTF and deploys as its commander, he normally establishes a rear detachment to provide continuity of peacetime JFSOCC functions and provide or arrange for support of the deployed JSOTF. A member of the command group or the SOJ5 is normally designated as the rear detachment commander. The composition of the rear detachment varies with the specific circumstances that caused its establishment.

(THIS PAGE INTENTIONALLY BLANK)

APPENDIX C

JOINT OPERATIONS CENTER

1. Purpose and Scope. This appendix describes the organization, responsibilities, and manning of the JOC within a JFSOCC headquarters.

2. General. The JOC within a JFSOCC headquarters serves as the C2 nerve center for joint SO. It processes all information related to planned and ongoing SO missions. It maintains close liaison with the operations centers of the JFC and the other component commanders. The success of joint SO varies directly with the effectiveness of the JOC.

3. Organization. The typical JOC is organized to facilitate integrated planning and synchronized execution (see Figure C-1). Staffing levels within the JOC vary depending on the mission. Each staff element develops a manning plan and organizes to operate on a 24-hour basis. Two 12-hour shifts are normal during sustained combat operations. During transition to a contingency operation or war, reduced peacetime SOC manning may dictate one-shift operations or two overlapping 16-hour shifts until augmentation personnel report for duty.

a. Director. The JOC director is usually the SOJ3 or his designated representative. The JOC director is the senior officer on duty in the JOC at any given time. The JOC director monitors the overall tactical situation and prepares at all times to respond to crises. Should a crisis arise requiring immediate action, the JOC director will contact the JFSOCC for guidance. If the JFSOCC is not immediately available, the JOC director must have the delegated authority to task SOF in response to changes in the tactical situation (for example, tasking an aircraft for emergency exfiltration of a team in contact). Some officer with this authority must be in the JOC at all times when there are ongoing operations.

b. Divisions. The JOC is normally divided into three distinct but collocated divisions: SOJ5 Plans, SOJ3 Operations, and Joint Intelligence Center (JIC). Each division chief establishes procedures for all shifts according to guidance received from the JOC director. The JOC also includes the liaison officers from supporting and subordinate units.

c. Physical Arrangement. The physical arrangement of the JOC will vary, depending on physical constraints. Figure C-2 depicts a typical JOC physical arrangement.

Figure C-1. Typical JOC Organization  
C-2

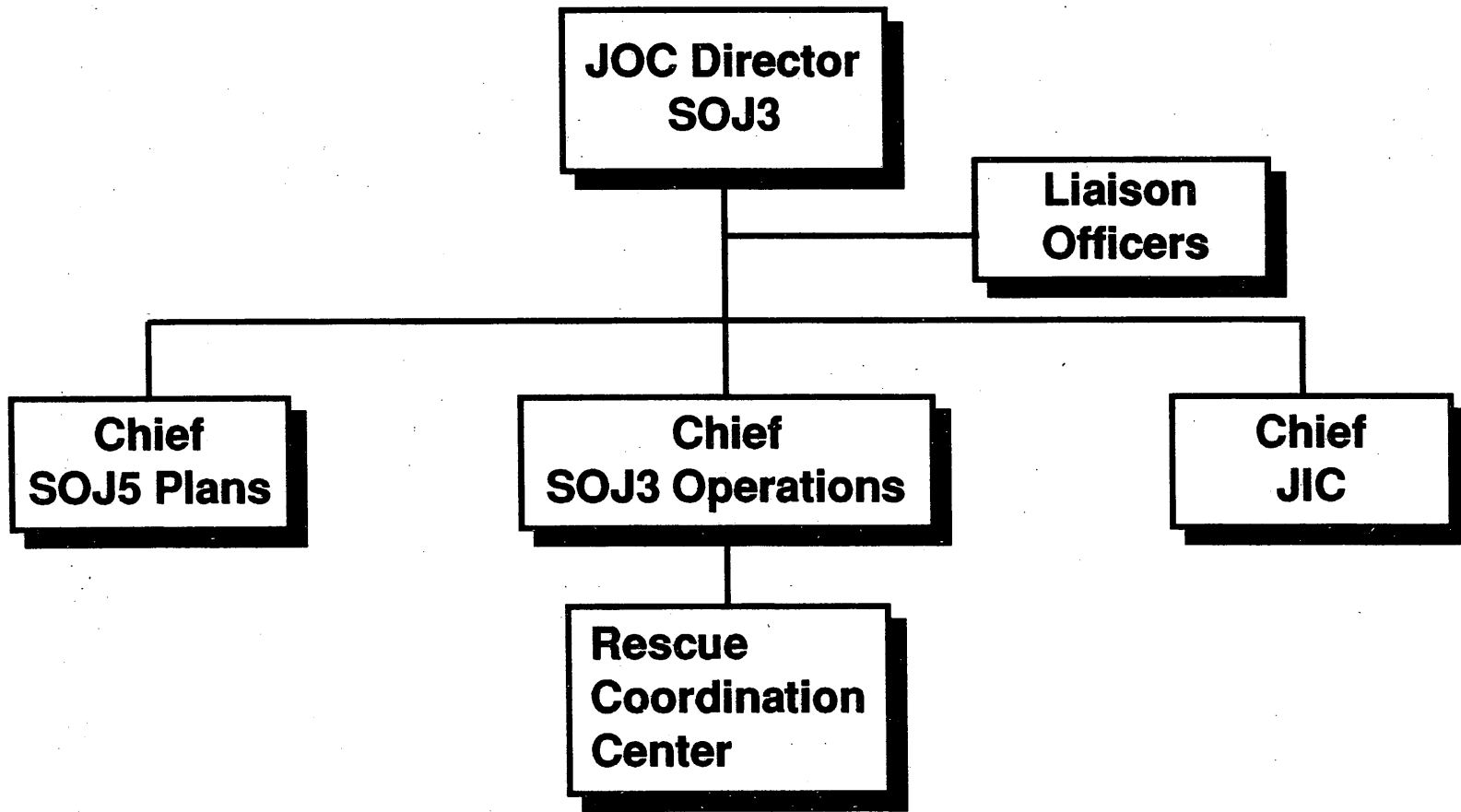

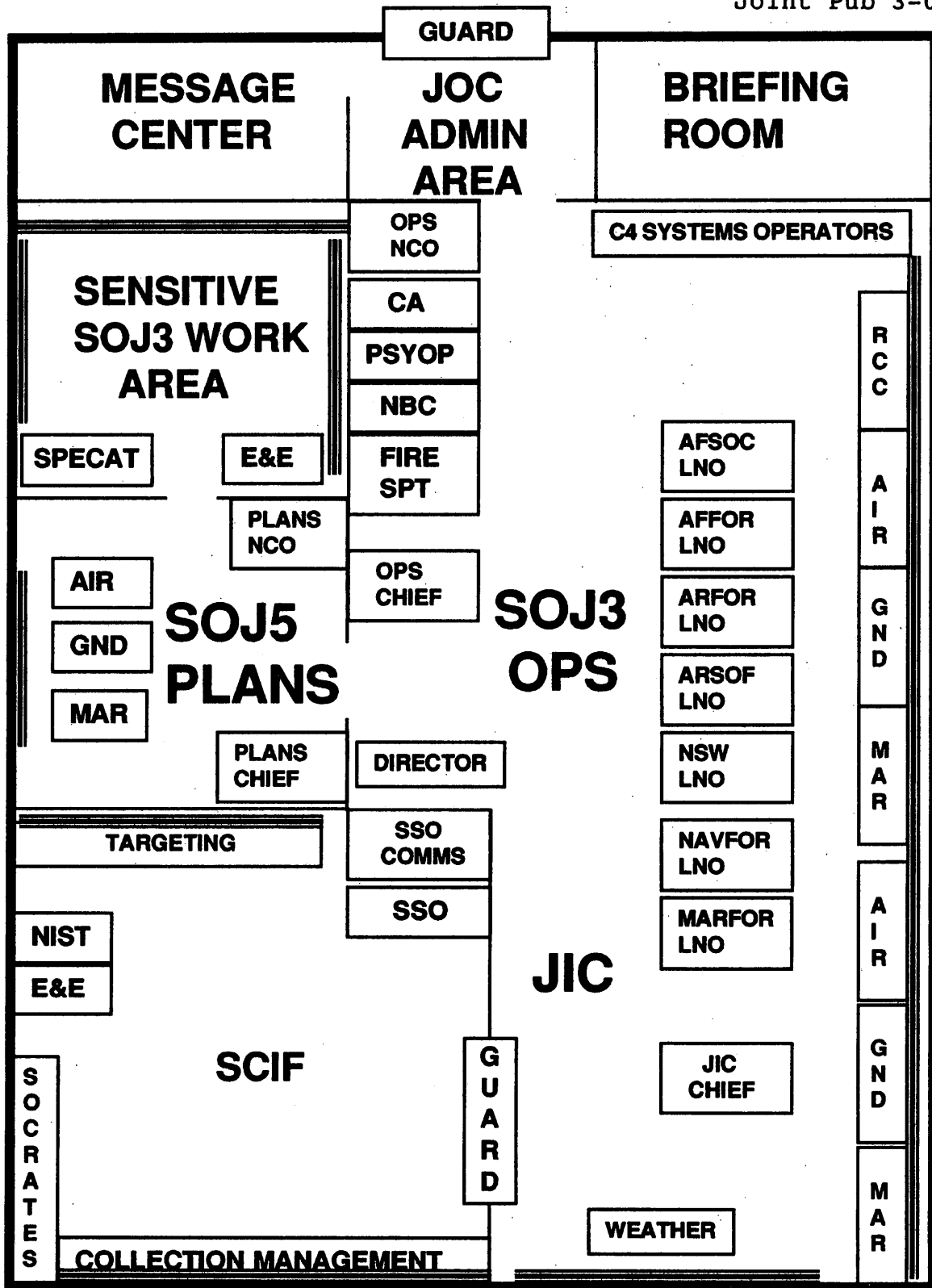

LEGEND:  
 MAP BOARD = **=====**  
 GND = GROUND  
 MAR = MARITIME  
 LNO = LIAISON OFFICER

Figure C-2. Typical JOC Physical Arrangement



It is important to position personnel to facilitate individual task accomplishment and coordination and information flow within and among sections. For example, the air, ground, and maritime operations desks are collocated and positioned close to JOC map boards and data displays.

4. SOJ5 Plans. The SOJ5 Plans division conducts targeting and operational planning for future operations. It coordinates special requirements such as JSOAs, RFAs and NFAs, and airspace allocation requests through JFSOCC liaison elements at the JFC or JFACC. It manages and resolves problems during the time-sensitive mission planning process. Typical SOJ5 Plans staffing includes:

a. SOJ5 Plans Chief. The SOJ5 plans chief is responsible for operational planning and premission coordination, to include:

(1) Ensuring daily command briefings and situation reports are prepared in a timely, accurate, and complete manner.

(2) Ensuring an effective communication and information flow between desk officers, other staff sections, and components.

(3) Establishing and enforcing internal SOPs.

b. SOJ5 Plans NCO. The SOJ5 plans NCO assists the plans chief in the overall management of the section by:

(1) Managing internal section administration.

(2) Supervising graphics support.

(3) Maintaining section equipment and supplies.

(4) Supervising enlisted personnel in the performance of their duties.

c. Ground Plans Branch. The ground plans branch is responsible for planning and coordinating the ground portions of joint SO. The duties of its ground operations officers include:

(1) Monitoring the status and location of uncommitted units capable of conducting ground operations.

(2) Monitoring and coordinating ground training activities.

(3) Coordinating and deconflicting future SOF ground operations and conventional ground operations, to include conventional ground support of joint SO.

(4) In conjunction with the air and maritime plans officers, coordinating and deconflicting future SOF ground operations and conventional air and naval operations.

(5) Preparing orders and assisting in the validation of MICONs.

(6) Monitoring the status of all ground military operations in theater.

(7) Preparing and delivering the ground portion of the daily command brief covering all ground activities for preceding and upcoming 24-hour period.

(8) Drafting the ground forces input for the daily situation report.

(9) Maintaining a journal of all activities conducted during his shift.

d. Maritime Plans Branch. The duties of the maritime plans branch mirror those of the ground plans branch except that its responsibilities relate to maritime operations.

e. Air Plans Branch. The duties of the air plans branch mirror those of the ground and maritime plans branches except that its responsibilities relate to air operations.

5. SOJ3 Operations. The SOJ3 Operations division monitors the real-time and near-term tactical situation and controls all ongoing joint SO. The section should include:

a. SOJ3 Operations Chief. The SOJ3 operations chief is responsible for tracking and controlling current operations and mission execution, to include:

(1) Ensuring situation maps and status boards are accurate and complete.

(2) Ensuring continuous communications and information flow between the JOC and higher, lateral, supported, supporting, and subordinate headquarters.

(3) Establishing and enforcing internal SOPs.

b. SOJ3 Operations NCO. The SOJ3 operations NCO assists the operations chief in the overall management of the section and is responsible for:

- (1) Managing internal section administration.
- (2) Supervising graphics support.
- (3) Maintaining section equipment and supplies.
- (4) Supervising enlisted personnel in the performance of their duties.

c. Ground Operations Branch. The ground operations branch monitors current ground operations. The duties of its ground operations officers and NCOs include:

- (1) Monitoring the status and location of committed SOF elements conducting ground operations.
- (2) In conjunction with air and maritime operations officers, monitoring and coordinating infiltration, resupply, and exfiltration of SOF elements conducting ground operations.
- (3) Coordinating and deconflicting current ground operations between SOF and conventional forces.
- (4) In conjunction with the air and maritime operations officers, coordinating and deconflicting SOF ground operations and conventional air and naval operations.
- (5) Preparing orders and other message traffic related to current operations.
- (6) Maintaining a journal of all activities conducted during their shift.

d. Maritime Operations Branch. The duties of the maritime operations branch mirror those of the ground operations branch except that its responsibilities relate to maritime operations.

e. Air Operations Branch. The duties of the air operations branch mirror those of the ground and maritime officers except that their responsibilities relate to air operations.

f. Rescue Coordination Center. The RCC is manned with personnel responsible for coordinating SOF CSAR operations. The RCC is focal point for the theater JRCC

to request SOF assistance and for the JFSOCC to request CSAR assistance. The RCC provides CSAR liaison personnel to the joint rescue coordination center (JRCC) as directed by the JFC.

g. Operational Support Branch. The operational support branch consists of the CA, PSYOP, NBC, OPSEC, fire support, and other special staff officers with functional combat support expertise. These staff officers assist the SOJ3 and SOJ5 in developing and producing operational concepts, plans, and orders. They also play a key role coordinating and deconflicting current and future operations with the JFC and other component staffs.

h. C4 Systems Operators. These personnel operate and maintain all C4 systems within the JOC.

6. Joint Intelligence Center. Under the staff supervision of the SOJ2, the JIC is responsible for the collection, analysis, and production of intelligence data to support the JFSOCC and subordinate component commanders.

a. JIC Chief. The JIC chief is the senior SOJ2 officer on duty in the JIC at any given time. The JIC chief directs the activities of the JIC, to include:

(1) Managing, coordinating, and directing the collection, analysis, and production of current intelligence.

(2) Editing current intelligence products.

(3) Screening message traffic for significant intelligence items; distributing message traffic as required.

(4) Maintaining the current intelligence estimate and ensuring accuracy of intelligence situation graphics.

(5) Preparing the intelligence portions of operations plans and orders.

b. SOJ2 Operations Chief. The SOJ2 Operations Chief directs the current intelligence activities of the JFSOCC, including collection management, order of battle analysis, intelligence liaison, and provision of environmental support.

c. Collection Management Branch. The collection management branch reports to the SOJ2 operations chief. It receives, reviews, consolidates, and prioritizes the

intelligence requirements of the JFSOCC and subordinate SOF components and manages the collection of intelligence data to satisfy those requirements.

(1) HUMINT Section. The HUMINT section coordinates HUMINT requirements and activities with the collection management branch, SOF components, and theater and national HUMINT agencies. It provides multi-discipline counterintelligence analysis and production to the SOJ2. It also supports SOJ3 deception and OPSEC planning.

(2) SIGINT Section. The SIGINT section coordinates SIGINT requirements and activities with the collection management branch, SOF components, and theater and national SIGINT agencies.

(3) IMINT Section. The IMINT section coordinates IMINT requirements and activities within the collection management branch, SOF components, and theater and national IMINT agencies.

d. Order of Battle Branch. The OB branch reports to the SOJ2 operations chief. Its ground, maritime, air, and electronic OB analysts are responsible for:

(1) Accuracy of their portions of the current intelligence estimate and situation graphics.

(2) Monitoring and analyzing the threat to SOF.

(3) Providing intelligence data in support of targeting.

(4) Preparing intelligence summaries.

(5) Maintaining close and continuous coordination with SOF unit intelligence officers.

e. Environmental Support Branch. The environmental support branch reports to the SOJ2 operations chief. It provides the JFSOCC staff with:

(1) Current weather and hydrographic data.

(2) Climatic and oceanographic planning data.

(3) Connectivity with appropriate environmental support agencies.

(4) Mapping, charting, and geodesy support.

f. SOJ2 Plans Chief. The SOJ2 Plans Chief is responsible for the preparation of the intelligence portions of plans and orders, intelligence support of the SOJ5 targeting effort, management of target intelligence package (TIP) production (see Joint Pub 3-05.5), intelligence research, and maintenance of the SOJ2 intelligence library.

(1) Research and Publications Branch. The research and publications branch maintains the SOJ2 intelligence library and conducts intelligence research in support of targeting, OB analysis, and the collection efforts of the JIC and subordinate SOF components.

(2) Targeting Branch. The targeting branch supports the activities of the JTCB and the JFSOCC target panel. The branch performs the following functions:

(a) Develop SOF target lists.

(b) Direct and manage TIP production.

(c) Maintain the JFSOCC targeting data base.

(3) Escape and Evasion Branch. The E&E branch supports E&E, CSAR, and SERE planning.

g. Special Security Officer. The SSO is responsible for all matters relating to the SCIF, including SCIF administration, security procedures, and communications. The SCI communications operators under SSO control maintain SCI communications connectivity and process all SCI message traffic.

h. SOJ2 Administrative NCOs. The SOJ2 administrative NCOs provide administrative support to the JIC. They assist in preparation of all intelligence products.

i. ADP Systems Operators. The ADP systems operators operate and maintain SOCRATES and other intelligence-specific ADP systems in support of intelligence analysis, collection and production management, and targeting.

7. Liaison Officers. LNOs are responsible for providing information and facilitating coordination between the JFSOCC and the supporting and subordinate units they represent. Each JFSOCC has theater-unique liaison requirements. See Appendix D for further details.

8. JOC Relationship with SOJ1 and SOJ4. The SOJ1 and SOJ4 work closely with the JOC to ensure that all current and future operations are supportable. The SOJ4 also coordinates resupply activities through the JOC when the tactical situation dictates that these activities be conducted as operational missions (see Chapter VIII for further details).

9. JOC Relationship with SOJ6. The SOJ6 works closely with the JOC to ensure that all current and future operations are supported by adequate C3 systems. The SOJ6 also ensures that all JOC C3 and ADP systems remain operational.

10. JOC Relationship with Legal Adviser. The legal adviser provides advice to the JOC Director on legal issues involved in SO planning and execution, including the law of armed conflict, rules of engagement, targeting, international law, and foreign law.

11. JOC Equipment. It is important that the JOC has the full array of available communications links to the JFSOCC components and to the JFSOCC liaison elements at other joint force components. The communications should be as redundant as possible and should offer both voice and data mediums through entirely different systems, should one system become saturated. The JOC should have the latest electronic equipment for C2 monitoring and real-time intelligence reporting. The value of portable STU III and lap-top computers cannot be overemphasized.

## APPENDIX D

## LIAISON OFFICER PROCEDURES

1. Purpose and Scope. This appendix addresses the responsibilities of the parent unit that prepares and deploys an LNO, the sponsor unit that the LNO represents, and the host unit that receives the LNO. LNOs are discussed in detail because of their importance in coordinating joint SO. Adequate liaison directly enhances the chances for mission success and protects employed SOF from fratricide. To be effective, sponsor and host units must plan for, properly train, and integrate LNOs into their headquarters operations.

2. General. Historically, LNOs have provided the critical link between the JFSOCC and higher, lateral, subordinate, supporting, and supported headquarters. LNOs from subordinate and supporting units provide the JFSOCC with current information about their parent units' capabilities, activities, and intentions. LNOs sponsored by the JFSOCC at higher and supported headquarters improve the JFSOCC's coordination with those headquarters by providing dedicated communications links and simply being present during critical phases of mission planning and execution. The size, composition and duration of liaison elements vary with the situation. Operation JUST CAUSE required a significant number of LNOs for short-term attachment. Operations DESERT SHIELD and DESERT STORM required large SO liaison elements at supported conventional headquarters on a permanent basis. The JFSOCC must identify liaison manpower and equipment requirements in all plans.

3. Parent Unit Responsibilities. LNOs may come from subordinate headquarters or tactical units. All SOF units must anticipate their taskings to provide LNOs. Personnel identified for LNO duty must have an extensive operational background and be able to represent the JFSOCC or advise him as the circumstances require. LNOs identified for duty outside the JFSOCC must have a thorough knowledge of all SOF components and SO doctrine, as well as a working knowledge of other applicable joint doctrine and TTP. LNOs should be identified before tasking and developed through training, schools, and exercise participation.

4. Sponsor Unit Responsibilities. The sponsor unit must appreciate the toll that the loss of LNOs will have on the parent units and strategically place them at the critical nodes of an operation. Thorough planning will limit the number to an absolute minimum and ensure they are well supported and effective when deployed. Sponsor units should:



- a. Brief new LNOs on the current missions, situation, activities, and intentions of the sponsor and host units. Include the overall concept of operations if appropriate, with emphasis on critical phases for SO. Highlight the areas of concern for joint coordination. Give the LNO a clear statement of his mission, chain of command, and reporting requirements.
- b. Discuss OPSEC considerations for the overall mission and for the SO portion of it. Unless compartmentation is necessary, the LNO should know all SOF units involved in the operation and the appropriate method to contact them.
- c. Outline the specific liaison requirements as coordinated with each of the sponsor's staff sections.
- d. Ensure that communication, support, and transportation arrangements meet mission requirements. Provide instruction if necessary. Ensure LNOs understand all reports, messages, and checklists. Provide any required authentication materials and COMSEC devices.
- e. Provide any necessary credentials for identification and coordinate diplomatic and security clearances.
- f. Provide the LNO with appropriate points of contact at the host unit in case of problems.
- g. If conducting liaison with an allied unit, ensure thorough coordination with the parent unit before LNO selection and arrange an interpreter if required.
- h. Coordinate with the parent unit before LNO deployment for the necessary mobility gear (equipment, clothing, weapons, chemical gear, etc.) and paperwork (shot records, passports, weapons cards, etc.). If the parent unit cannot provide these items, the sponsor unit must arrange for them.

5. Host Unit Responsibilities. The host unit should recognize the key role of LNOs in joint synchronization and assimilate them into its headquarters operations. The host unit should include LNOs within the information loop for all routine activity and provide them adequate working space, access, and administrative support. LNOs should be introduced to all staff principals, added to routing slips and staff directories, invited to attend meetings (such as daily situation and target panel), and involved in JOC activities. The host unit headquarters commander is normally responsible for integrating LNOs into the headquarters.

APPENDIX E

SOF MESSAGE FORMATS

1. Purpose and Scope. This appendix provides supplementary SO-peculiar procedures that complement the multi-Service "Joint User Handbook for Message Text Formats."

2. General. USMTF procedures are published in Joint Pub 3-56.24. Of the 220 USMTFs currently available, about 140 apply to SO. All SOF headquarters should obtain USMTF software and require use of the USMTF system. Below is a directory of the supplementary procedures in this appendix.

- a. Mission Tasking (MITASK, page E-1).
- b. Mission Concept (MICON, page E-4).
- c. Mission Support Request (MSR, page E-6).
- d. Mission Concept Approval (MCA, page E-10).
- e. Mission Support Confirmation (MSC, page E-11).
- f. Operations Summary (OPSUM, page E-12).

3. Mission Tasking. The JFSOCC uses the MITASK to assign missions to subordinate tactical units. Reference missions contained within an OPORD or other controlling directive rather than repeating them. The MITASK designates the MPA, supporting agencies, and IPA; grants direct liaison authority (DIRLAUTH); and establishes an EALT. Acknowledgment of the MITASK is required.

a. Timing. The JFSOCC should transmit the MITASK within 4 hours of mission receipt.

b. Baseline Format

- (1) Basic Message Name. ORDER.
- (2) MSGID. ORDER.
- (3) ORDTYP. MITASK.
- (4) Mandatory Data Sets. MSGID, ORDTYP, TIMEZONE, AKNLDG.

c. Special Instructions

- (1) GENTEXT/SITUATION. Provide an overview of the general situation using the following headings:

- (a) ENEMY FORCES. Provide enemy composition, disposition, capabilities, vulnerabilities, and intentions. Refer to intelligence annexes, summaries, or other reports. If no change from the last referenced intelligence summary, indicate "NO CHANGE."
- (b) FRIENDLY FORCES. Provide information on friendly forces other than those subordinate to the JFSOCC that may affect the action of the MPA.
- (c) ATTACHMENTS AND DETACHMENTS. List units attached to, or detached from, subordinate units of the JFSOCC.
- (2) GENTEXT/MISSION. Provide a clear, concise statement of the task and purpose. Assign a mission designator (see Appendix H).
- (3) GENTEXT/EXECUTION. Include the following:
- (a) CONCEPT OF OPERATIONS. Summarize what the JFSOCC wants the mission to accomplish without specifying how to do it. Provide the JFSOCC's intent and the desired effects. Avoid excessive detail that may limit the MPA's planning. Do not make assumptions regarding techniques.
- (b) SUBORDINATE TASKS. List tasks by component, with each component receiving its own paragraph. List tasks common to two or more components under coordinating instructions. Designate the MPA and supporting agencies. Establish suspense for MICON submission.
- (c) COORDINATING INSTRUCTIONS. Establish the EALT and state any other instructions for coordination when the mission will be joint and/or involve conventional forces. Include EEI, safety guidance, ROE, and other planning limitations when applicable. Include specific points of contact when possible.
- (4) GENTEXT/ADMIN AND LOG. State the applicable administrative and logistic support arrangements. Refer to OPORD annexes when appropriate.
- (5) GENTEXT/COMMAND AND SIGNAL. Indicate any changes to the C-E policy, headquarters locations, code words, code names, and liaison. If no change, indicate "NO CHANGE."

d. Notional MITASK

OPER/COASTAL WATCH//  
 MSGID/ORDER/COMSOC//  
 ORDTYP/MITASK/COMSOC/0001//  
 TIMEZONE/Z//  
 ORDREF/OPLAN/COMSOC XXX//  
 HEADING/TASK ORGANIZATION//  
 5UNIT  
 /UNITDES /UNITLOC/CMNTS//  
 /3RD SOW /AFSOB 3/6 AC-130, 5 MC-130, 10 MH-60, 8 MH-53//  
 /9TH SFGA /SFOB 9//  
 /1/75TH RGR BN/SFOB 9//  
 GENTEXT/SITUATION/  
 1. ( ) ELEMENTS OF THE ARMED FORCES OF SAN SEBASTIAN HAVE OVERTHROWN FRIENDLY GOVERNMENT OF SAN SEBASTIAN AND DECLARED MARTIAL LAW IN EFFECT. AIRPORT CLOSED TO CIVILIAN TRAFFIC. ESTIMATED 200 AMCITS IN COUNTRY HAVE TAKEN REFUGE IN AMEMB. AMBASSADOR HAS REQUESTED NEO.  
 A. ( ) ENEMY FORCES: SAN SEBASTIAN HAS 500-MAN LIGHT INF BN AND 100-MAN POLICE FORCE VIC CAPITAL. AIR FORCE HAS 12 A-37 AIRCRAFT AND 4-6 SA-2/SA-3 SYSTEMS.  
 B. ( ) FRIENDLY FORCES: AFFOR AND NAVFOR SUPPORT NEO AS REQUIRED. AMEMB MARINE GUARD WILL PROVIDE TERMINAL GUIDANCE AT COMPOUND.  
 C. ( ) ATTACHMENTS AND DETACHMENTS: 1/75TH RANGER BN ATTACHED 9TH SFGA TO FORM ARSOTF BLACK.//  
 GENTEXT/MISSION/  
 2. ( ) JSOTF SAN SEBASTIAN CONDUCTS SPECIAL OPERATIONS TO EVACUATE APPROX 200 AMCITS AND 60 AMEMB STAFF FROM AMEMB SAN SEBASTIAN (SO001/SFG9).//  
 GENTEXT/EXECUTION/  
 3. ( ) CONCEPT OF OPERATIONS: 9TH SFG ESTABLISHES JSOTF AND DEPLOYS JOINT SOF FROM SFOB 9 USING 3RD SOW ASSETS TO SECURE AMEMB AND EVACUATE APPROX 260 AMCITS AND AMEMB STAFF MEMBERS TO FRIENDLY CONTROL.  
 4. ( ) 9TH SFG: PLAN AND CONDUCT NEO AS COMJSOTF SAN SEBASTIAN.  
 5. ( ) 3RD SOW: PLAN AND CONDUCT SPECIAL AIR OPERATIONS AS JSOACC OF JSOTF SAN SEBASTIAN.  
 6. ( ) COORDINATING INSTRUCTIONS:  
 A. ( ) 9TH SFG IS MPA. 3RD SOW IS SUPPORTING AGENCY. THEATER JIC IS IPA.  
 B. ( ) EALT IS 122300Z MAY.  
 C. ( ) PEACETIME ROE IN EFFECT.  
 D. ( ) SUBMIT MICON NLT 082300Z MAY.//  
 GENTEXT/ADMIN AND LOG/  
 7. ( ) ANNEX D (SERVICE SUPPORT) AND ANNEX E (PERSONNEL), ORDREF IN EFFECT.//  
 GENTEXT/COMMAND AND SIGNAL/  
 8. ( ) ANNEX K (C-E), ORDREF IN EFFECT.//  
 GENTEXT/AUTHENTICATION/BANKS,BG OFFICIAL: SMITH, COL SOJ3//  
 AKNLDG/Y//  
 DECL/OADR//

4. Mission Concept The MICON is the MPA response to the MITASK. It provides the MPA's concept of operations in sufficient detail for the JFSOCC to evaluate the concept and approve it for execution planning.

a. Timing. The MPA should transmit the MICON at least 72 hours before the EALT.

b. Baseline Format

(1) Basic Message Name. ORDER.

(2) MSGID. ORDER.

(3) ORDTYP. MICON.

(4) Mandatory Data Sets. MSGID, ORDTYP, TIMEZONE, AKNLDG.

c. Special Instructions

(1) GENTEXT/SITUATION. State relevant additional information that was not included in the MITASK or other references. If no change, state "NO CHANGE."

(2) GENTEXT/MISSION. Provide the MPA's restated mission as derived during analysis of the MITASK. Repeat the mission designator from the MITASK.

(3) GENTEXT/EXECUTION. Include the following:

(a) CONCEPT OF OPERATIONS. Enter a general statement of how the commander intends to accomplish the mission, including the major forces involved, time phasing, cross-service support, and necessary coordination.

(b) SUBUNIT TASKS. Enter a paragraph for each operational subunit. Include the operational unit designator; time, place, and means of infiltration and exfiltration; and specific mission tasks. This section forms the basis for information transmitted in the accompanying MSR.

(c) COORDINATION. Identify coordination requirements for mission support from other SOF components. Indicate what mission support requests have been sent, to whom, and when coordination must be completed. Identify necessary JFSOCC assistance.

(d) OPERATIONAL LIMITATIONS. Include estimate for probability of mission success (high, medium or low) once in the JSOA. If none, state "NONE."

d. Notional MICON

OPER/COASTAL WATCH//

MSGID/ORDER/COMJSOTF SAN SEBASTIAN//

ORDTYP/MICON/001//

TIMEZONE/Z//

ORDREF/MITASK/COMSOC 001//

GENTEXT/SITUATION/NO CHANGE//

GENTEXT/MISSION/

1. ( ) JSOTF CONDUCTS SPECIAL OPERATIONS 122300Z MAY 9 TO SECURE AMEMB SAN SEBASTIAN AND EVACUATE APPROX 260 AMCITS AND AMEMB STAFF FROM AMEMB TO FRIENDLY CONTROL. (SO001/SFG9).//  
GENTEXT/EXECUTION/

2. ( ) CONCEPT OF OPERATIONS: JSOTF PLANS AND PREPARES FOR MISSION AT SFOB 9 AND AFSOB 3. ON NIGHT 09/10 MAY JSOTF SUPPORT ELEMENT ESTABLISHES STAGING BASE AT US NAS RIO BRAVO TO SUPPORT OPERATION WITH COMBINATION OF JOINT AND COMMON SERVICING. ON NIGHT 10/11 MAY JSOTF INFILTRATES SF SR TEAM (ODA 911) BY MC-130 FROM SFOB 9 TO PLACE SURVEILLANCE ON HOSTILE INF BN BARRACKS; EXTRACT BY MH-60 ON ORDER. ON NIGHT OF 11/12 MAY JSOTF (-) DEPLOYS TO STAGING BASE. AT 130030 MAY JSOTF INSERTS SF DA TEAM (ODA'S 912, 914) BY MH-60 TO DISABLE HOSTILE EARLY WARNING AND AIR DEFENSE CAPABILITIES; TEAM EXTRACTS BY MH-60 ON MISSION COMPLETION. AT 130100 MAY JSOTF GROUND TASK FORCE (A/1/75TH RGR, B/1/75TH RGR AND C/1/9TH SFG) AIR ASSAULTS INTO AMEMB COMPOUND BY MH-53 TO SECURE COMPOUND PERIMETER AND EVACUATE APPROX 260 AMCITS AND AMEMB STAFF USING SAME AIRCRAFT. AFSOF AC-130 AIRCRAFT PROVIDE CLOSE AIR SUPPORT AS REQUIRED. COMJSOTF CONTROLS OPERATION FROM EC-130 ABCCC.

3. ( ) 9TH SFG: CONDUCT SR SURVEILLANCE MISSION AGAINST HOSTILE INF BN BARRACKS. CONDUCT DA STRIKE TO DISABLE HOSTILE EARLY WARNING AND AIR DEFENSE CAPABILITIES. PROVIDE IN-EXTREMIS CT FORCE (ODB, 4 ODB) TO GROUND TASK FORCE CDR TO PROVIDE CLOSE-IN PROTECTION TO AMCITS AND AMEMB STAFF DURING EVACUATION.

4. ( ) 1/75TH RGR: PROVIDE GROUND TASK FORCE CDR. AIR ASSAULT INTO AMEMB COMPOUND TO SECURE COMPOUND PERIMETER, EVACUATE AMCITS AND AMEMB STAFF, AND DEFEND COMPOUND UNTIL RELIEVED OR WITHDRAWN.

5. ( ) 3RD SOW: INFILTRATE 3 SF SR TEAMS BY MC-130 AND EXTRACT BY MH-60. INSERT AND EXTRACT 3 SF DA TEAMS BY MH-60. AIR ASSAULT RGR/SF GROUND TASK FORCE INTO AMEMB COMPOUND BY MH-53 AND EVACUATE AMCITS AND AMEMB STAFF TO STAGING BASE BY MH-53. PROVIDE AC-130 CLOSE AIR SUPPORT AS REQUIRED. BE PREPARED TO CONDUCT CSAR.

6. ( ) COORDINATING INSTRUCTIONS:

A. ( ) MSR 001/081601/MAY.

B. ( ) AIRSUPREQ 001/081602/MAY.

7. ( ) OPERATIONAL LIMITATIONS: NONE.//

AKNLDG/NO//

DECL/OADR//

5. Mission Support Request. The MPA sends an MSR with the MICON to request operational support from one or more supporting agencies. The MSR is designed primarily for support from other SOF components; however the MSR may request that the JFSOCC or a supporting agency coordinate conventional unit support. The MSR should list all MPA support requirements and identify any preference for a particular supporting agency. The MPA may submit additional MSRs as planning continues.

a. Timing. The MPA should transmit the MSR with the MICON, no later than 72 hours before the EALT.

b. Baseline Format

(1) Basic Message Name. System-Reply or Remarks Message (A SO-unique USMTF MSR format has been submitted for approval as a USMTF with implementation date of 1 Oct 94.).

(2) MSGID. SYS.RRM.

(3) Mandatory Data Sets. MSGID, REPLY, RMKS.

c. Special Instructions. Use the System-Reply or Remarks Message (SYS.RRM) until a USMTF MSR message format has been approved for joint use. Enter the following information in the "RMKS" data set:

(1) Type Support Requested. Indicate whether the MSR is for:

(a) "PERSONNEL" (personnel augmentation). Include skill requirements, number requested, and any pertinent additional information.

(b) "OPERATIONS" (delivery, resupply, recovery, off-shore rendezvous, terminal guidance, etc.). Include the type of operation (infiltration, resupply, recovery, etc.), DTG for execution (specify by type of event, such as a TOT for insertion), method of execution (airdrop, lock-in/lock-out, etc.) desired, and type of platform desired (MC-130, MH-60, etc.). Indicate number of personnel and amount of cargo. Specify procedures used and type of parachute for airdrop requests.

(c) "TRAINING" (ranges, materiel, aircraft, vessels, etc.). Identify specific training requirements that are beyond organic capabilities. Specify any joint preparation required, including SOFPARS and mission rehearsal. Include times and dates.

(d) "ADMINISTRATION" or "LOGISTICS" (materiel, supplies, services, facilities, etc.). Identify specific administrative or logistic requirements that are beyond organic capabilities. Refer to OPLAN annexes, memorandums of agreement, or statements of requirements if appropriate. Includes times and dates.

(2) Supporting Agency. When using multiple addressees, clearly indicate what support each supporting agency is expected to coordinate.

(3) Number of Personnel. Indicate number of personnel requiring support.

(4) Cargo. Include material and supplies carried for infiltration as well as resupply. Note if the cargo is hazardous. Indicate how the material and supplies will be delivered (door bundle with parachute, free fall, pallet airdrop, etc.), the type of parachute, number of bundles, and total weight.

(5) Location. Identify or request a point, site, or zone. Refer to a specific reception site or beach landing site nomination or confirmation message, or specifically request the supporting agency to nominate primary and alternate sites. Transmit sufficient data to positively identify locations.

(6) CMTS. Include in this section any additional information facilitating coordination or highlighting special requirements. Such information may include on-load and off-load locations; pilot, aircrew, and team briefing requirements; drop altitude (above ground level); HALO or HAHO parachute opening altitude; etc.



d. Notional MSR

OPER/COASTAL WATCH//  
MSGID/SYS.RRM/CDR 9TH SFG//  
REF/A/ORDER/COMSOC/072130ZMAY92//  
AMPN/MITASK 001//  
REF/B/ORDER/CDR 9TH SFG/081600ZMAY92//  
AMPN/MICON 001//  
REPLY/VER//  
RMKS/

1. ( ) TYPE SUPPORT REQUESTED: OPERATIONS. SUPPORTING  
AGENCY: 3RD SOW. REQ FOLLOWING AIR MISSIONS TO SUPPORT OPS  
PER REF B. LOCATIONS PER ANNEX C, COMSOC OPLAN XXX.  
MARKINGS PER CURRENT JCEOI. AIR ASSAULT ACFT WILL EVACUATE  
APPROX 260 AMCITS AND AMEMB STAFF ESCORTED BY 40 SF PAX.  
MISSION DETAILS TO BE COORDINATED AT SFOB WITH JSOACC LNO.  
8REQUEST

/MSNNO /PR/MSNTYP/TOT /ACTYP/CMNT  
/ADI001/1 /INFILT/110200ZMAY9\_/MC130  
/OTR001/1 /TRANSP/112300ZMAY9\_/C130  
/ALI001/1 /INFILT/130030ZMAY9\_/MH60  
/OTR002/1 /ARASLT/130100ZMAY9\_/MH53  
/TAS001/1 /CAS /130100ZMAY9\_/AC130  
/ALE001/1 /EXFILT/132300ZMAY9\_/MH60  
/ALE002/1 /EXFILT/140200ZMAY9\_/MH60

8MSNLOC

/MSNNO /LOCTYP/PRILOC /ALTLOC /CMNT  
/ADI001/ /LZ BAKER /LZ BORIC  
/OTR001/ /NAS RIO BRAVO/NONE  
/ALI001/ /LZ BINGO /LZ BLITZ  
/OTR002/ /LZ BEACH /LZ BURKE  
/TAS001/ /ON STATION VIC AMEMB  
/ALE001/ /PZ BROWN /PZ BUGLE  
/ALE002/ /PZ BRITE/PZ BRONX

8LOADATA

/MSNNO /PAX/CGO /ONLOC/ONTIME  
/ADI001/10 / /LZ BAKER /LZ BORIC  
/OTR001/400/AMPN/NAS RIO BRAVO/NONE  
/ALI001/23 / /LZ BINGO /LZ BLITZ  
/OTR002/300/ /LZ BEACH /LZ BURKE  
/TAS001/ / /ON STATION VIC AMEMB  
/ALE001/23 / /PZ BROWN /PZ BUGLE  
/ALE002/10 / /PZ BRITE/PZ BRONX

AMPN/MSN SOF002 CGO CONSISTS OF 12 463L PALLETS, FOUR HMMV,  
TWO CGO TRUCKS WITH TRLRS.

8AIRDROP

/MSNNO /ELEV/DROPLOC /HDG/EDGMP/DZLG/DZWD/MRKING  
/ADI001/2100/123450N567890W/135/800 /3000/15000/NONE

2. (U) TYPE SUPPORT REQUESTED: LOGISTICS. SUPPORTING  
AGENCY: US NAS, RIO BRAVO. REQ PRECOORDINATED STAGING BASE  
FACILITIES AND SERVICES PER COMSOC OPLAN XXX AND COMNAVFOR/  
COMSOC MOA BE MADE AVAIL EFFECTIVE 10 MAY FOR DURATION OF NEO  
IN SAN SEBASTIAN.//

DECL/OADR//

6. Mission Concept Approval. The JFSOCC transmits the MCA to the MPA to approve, cancel, or modify the MPA's mission concept. Acknowledgment is required.

a. Timing. The JFSOCC will send the MCA as soon as possible after receipt of the MICON, normally within 8 hours.

b. Baseline Format

(1) Basic Message Name. ORDER.

(2) MSGID. ORDER.

(3) Mandatory Sets. MSGID, ORDTYP, ORDREF, AKNLDG.

c. Special Instructions

(1) ORDTYP. Use EXORD if MCA constitutes approval to execute mission. Use OTR if MCA cancels mission or authorizes MCA to continue execution planning and preparation pending execution authority.

(2) ORDREF. Reference the MICON message that the MCA approves, cancels, or modifies.

(3) GENTEXT/SITUATION. Briefly state additional general situation information significant to this message. If no change, state "NO CHANGE."

(4) GENTEXT/MISSION. Restate mission if it has changed. Otherwise, state "NO CHANGE."

(5) GENTEXT/EXECUTION. Approve referenced MICON or provide additional guidance.

(6) GENTEXT/ADMIN AND LOG. Provide any changes. Otherwise, state "NO CHANGE."

(7) GENTEXT/COMMAND AND SIGNAL. Indicate any changes from MITASK. Otherwise, state "NO CHANGE."

d. Notional MCA

OPER/COASTAL WATCH//  
MSGID/ORDER/COMSOC//  
ORDTYP/OTR/COMSOC/0001//  
TIMEZONE/Z//  
ORDREF/MICON/CDR 9TH SFG/001//  
GENTEXT/SITUATION/ ( ) SITUATION IN SAN SEBASTIAN REMAINS  
GRAVE. NCA HAVE NOT YET AUTHORIZED USE OF MILITARY FORCE TO  
CONDUCT NEO IN RESPONSE TO AMBASSADOR REQUEST.//  
GENTEXT/MISSION/ ( ) NO CHANGE (SO001/SFG9).//  
GENTEXT/EXECUTION/ ( ) MICON APPROVED FOR EXECUTION  
PLANNING AND PREPARATION AS SUBMITTED. DO NOT DEPLOY FORCES  
FROM PRESENT LOCATIONS WITHOUT EXECUTE ORDER FROM THIS HQ.//  
GENTEXT/ADMIN AND LOG/ ( ) NO CHANGE.//  
GENTEXT/COMMAND AND SIGNAL/ ( ) NO CHANGE.//  
GENTEXT/AUTHENTICATION/BANKS,BG OFFICIAL: SMITH, COL SOJ3//  
AKNLDG/Y//  
DECL/OADR//

7. Mission Support Confirmation. Supporting agencies transmit the MSC to the MPA, JSOCC, and tasked subordinate supporting unit(s) to confirm details of requested mission support, except for air support. (Use the standard REQCONF format to confirm air support.)

a. Timing. The supporting agency should transmit the MSC no later than 48 hours before the EALT.

b. Baseline Format

- (1) Basic Message Name. RRI.
- (2) MSGID. RRI.
- (3) Mandatory Sets. REF and RMKS.

c. Special Instructions. Insert an AMPN free-text set after each formatted set to provide additional information. Additionally, a RMKS set is available as the last set in the main text.

(1) REF. The REF set should reference the MSR(s) requesting mission support confirmed in the message.

(2) RMKS. Use the RMKS set to--

(a) Confirm details such as the number of personnel, amount of supplies, type of vessel or vehicle to be used, location of offshore rendezvous point (to eight digit coordinates when possible); and BLS clear signal (if required).

(b) Highlight problems or request action, such as MPA acknowledgment and acceptance of a change to the support requested.

(c) Request additional information from the MPA or JSOCC. Provide a point of contact and time that the additional information must be received.

d. Notional MSC

OPER/COASTAL WATCH  
MSGID/RRI/COMNAVAIRSTA RIO BRAVO//  
REF/A/SYS.RRM/9TH SFGA/081601ZMAY9\_//  
AMPN/MSR 001//  
RMKS/

1. ( ) PRECOORDINATED STAGING BASE FACILITIES AND SERVICES AVAILABLE PER YOUR REF A EFFECTIVE 101200ZMAY9\_, EXCEPT AS NOTED IN PARA 2.

2. ( ) ONE 44-PAX BUS UNAVAIL. WILL SUBSTITUTE THREE 14-PAX VANS UNLESS OTHERWISE DIRECTED.

3. ( ) REQ FOLLOWING INFO ASAP:

A. ( ) SIZE OF ADVON AND EXPECTED TIME OF ARRIVAL.

B. ( ) ACTUAL NUMBER OF PERSONNEL FOR MESSING.//

DECL/OADR//

8. Operations Summary. JFSOCC component commanders submit an OPSUM to the JFSOCC after the post-mission recovery and debriefing of a SOF tactical element.

a. Timing. Submit OPSUM as soon as possible after the element's initial debriefing. Submit change to this initial OPSUM after final debriefing if appropriate.

b. Baseline Format

(1) Basic Message Name. OPERATIONS SUMMARY.

(2) MSGID. OPSUM.

(3) Mandatory Sets. MSGID, PERID.

c. Special Instructions

(1) PERID. Use field one to indicate the day and time the mission began, field two to indicate the day and time the mission was completed.

(2) GENTEXT/GROUND OPSUM/. Use this data set after the PERID set. Field two is for the following free-text comments, as appropriate:

(a) Target location and identification.

- (b) Purpose of mission.
- (c) Composition of team.
- (d) Evaluation of results. State whether original plan was followed (if not, outline deviations and rationale). State whether mission was successful or unsuccessful (if unsuccessful, outline the reasons).
- (e) Friendly losses.
- (f) Enemy losses. Indicate count or estimate.
- (g) Significant observations.
- (h) EEI.
- (i) Other significant information.
- (j) Recommendations.

d. Notional OPSUM:

OPER/COASTAL WATCH//  
 MSGID/OPSUM/9TH SFG//  
 PERID/122300Z/TO:130600Z//  
 GENTEXT/GROUND OPSUM/

1. ( ) TARGET IDENTIFICATION AND LOCATION. AMEMB SAN SEBASTIAN, 45QAB123456.
  2. ( ) TEAM MISSION. CONDUCT AIR ASSAULT 130100ZMAY9\_ INTO AMEMB COMPOUND BY MH-53 TO SECURE COMPOUND PERIMETER AND EVACUATE APPROX 260 AMCITS AND AMEMB STAFF BY MH-53.
  3. ( ) TEAM COMPOSITION. GROUND TASK FORCE CONSISTED OF TWO RANGER COMPANIES (A, B/1/75 RGR) AND C/1/9 SFG UNDER COMMAND OF 1/75 RGR BN CDR AND STAFF.
  4. ( ) EVALUATION OF RESULTS:
    - A. ( ) ORIGINAL PLAN FOLLOWED.
    - B. ( ) MISSION SUCCESSFUL. ALL 262 AMCITS EVACUATED FROM AMEMB COMPOUND WITH MINIMAL FRIENDLY CASUALTIES AND MINIMAL COLLATERAL DAMAGE.
  5. ( ) FRIENDLY LOSSES. ONE SF KIA, TWO RANGERS WIA, FOUR AMCITS WIA. NAMES WITHHELD PENDING NOTIFICATION OF NOK.
  6. ( ) ENEMY LOSSES. ESTIMATED 40 CASUALTIES FROM FRIENDLY SMALL ARMS. NEARBY ARMY BARRACKS DESTROYED BY AC-130 GUNFIRE. TWO POLICE VEHICLES DESTROYED BY AT-4S.
  7. ( ) SIGNIFICANT OBSERVATIONS. NONE.
  8. ( ) EEI. NONE.
  9. ( ) OTHER SIGNIFICANT INFORMATION. ONE MH-53 TOOK 27 HITS AND COMPLETED MISSION WITHOUT FAILURE.
  10. ( ) RECOMMENDATIONS. NONE.//
- DECL/OADR//

## APPENDIX F

## PEACETIME PLANNING AGENCIES

1. Purpose and Scope. This appendix reviews the missions of non-DOD agencies that are routinely involved in the same regional strategies and peacetime campaign objectives as SOF. In many instances, SOF may find itself involved with these agencies in planning and conducting contingencies and other operations supporting US foreign policy initiatives.

2. General. DOD peacetime SO are normally cooperative operations that support another US Government agency responsible for an overall mission. For example, in support to counterinsurgency, the DOS is the lead agency and works through the Ambassador and the Country Team. DOD involvement depends upon the criticality of US interests, the threat, and the capabilities and desires of the host government or group.

3. Department of State. As the senior executive department of the US Government, the DOS advises the President in the formulation and execution of all foreign policy issues that affect US policy. DOS activities include:

a. Determining and analyzing facts relating to US interests overseas.

b. Making recommendations on future policy and taking the necessary steps to carry out established policy.

c. Speaking for the United States in the United Nations and in more than 50 major international organizations in which the United States participates.

d. Accepting overall responsibility for formulating and implementing policy regarding foreign economic matters, including resource and food policy, international energy issues, trade controls, international finance and development, and aviation and maritime affairs.

e. Coordinating programs of intelligence, research, and analysis in matters relating to conflict and maintaining liaison with cultural and educational institutions and with other Federal agencies on a wide range of matters relating to the US Government contractual and private foreign affairs research.

f. Developing and funding security assistance programs as established under the Foreign Assistance Act of 1961, as amended, and the Arms Export Control Act, as amended. These programs provide economic and military assistance, training, and materials to foreign nations by grant, credit, or cash sales to further US goals and objectives.

4. Agency for International Development. USAID carries out economic assistance programs designed to help the people of developing countries develop their human economic resources, increase their productive capacities, and improve the quality of human life as well as promote economic and political stability in friendly countries. Activities include:

a. Carrying out the provisions of the Agricultural Trade Development and Assistance Act of 1954, as amended, in cooperation with the Departments of Agriculture and State. This includes the sale of agricultural commodities on concessional terms, the donation of agricultural commodities, and the provision of food under the Food for Development Program.

b. Emphasizing four major thrusts to achieve successful economic development:

(1) Use market forces to stimulate growth of market economies in developing countries, and encourage US companies to invest in those countries.

(2) Engage in policy dialog to encourage those countries that receive US assistance to adopt rational economic policies that foster economic growth.

(3) Build institutions that support and sustain growth, such as schools, colleges, training organizations, and supportive government ministries.

(4) Stimulate practical technology transfer to enable countries to exploit their own resources.

c. Focusing development assistance programs on critical problem areas in those functional sectors that affect the majority of people in the developing countries, including:

(1) Agriculture, rural development, and nutrition.

(2) Health.

(3) Population planning.

(4) Education and human resource development.

(5) Energy, private and voluntary organizations, and selected development activities.

(6) Private enterprise.

d. Assisting in the implementation of the US Economic Support Fund, which supports US economic, political, and security interests and advances US foreign policy goals. The Economic Support Fund is a flexible economic assistance grant or loan program to sustain economic activity and restore financial equilibrium for those nations faced with economic and political disruption caused by conflict.

e. Providing public information on past and ongoing US actions to assist the host government in its economic development. This covers the level of US support, indigenous participation, and progress.

5. United States Information Agency. USIA functions as lead agency for all US Government information actions outside the United States. Responsibilities include:

a. Coordinating with host government for opportunities for US news media to cover host-government actions.

b. Employing cultural affairs resources to amplify host government relations with the United States, and its plans and programs to use US assistance to benefit its people.

c. In support of a counterinsurgency effort, using broadcast facilities to erode insurgent support base and inform indigenous population of government progress in defeating rival groups.

6. International Development Cooperation Agency. The IDCA serves as the principal international development adviser to the President and to the Secretary of State, subject to guidance concerning the foreign policy of the United States from the Secretary of State. IDCA activities include:

a. Coordinating policy on international economic issues affecting developing countries.

b. Ensuring that development goals are taken fully into account in all US executive-level decisions on trade, finance, technology, and other economic policy issues affecting less developed nations.

c. Promoting and coordinating a coherent development strategy through the effective use of US bilateral development assistance programs and US participation in multilateral development organizations.

d. Executing lead budget and policy responsibility for US participation in the UN and Organization of American States programs.



e. Sharing responsibility for the multilateral development banks (the World Bank Group and the regional development banks) with the Secretary of the Treasury.

f. Sharing responsibility for the Food for Peace Program with the Department of Agriculture.

g. Providing the chair for the Development Coordination Committee, a broad interagency body that coordinates development and development-related policies and programs. This group prepares and submits to Congress an annual report outlining efforts undertaken by the US Government in the past year to promote international economic development and key issues in the development field.

7. Central Intelligence Agency. The CIA advises and makes recommendations to the National Security Council in matters concerning and implementation of US intelligence activities and agencies as they relate to national security. Generic responsibilities include:

a. Correlating and evaluating intelligence relating to national security and disseminating such intelligence within the US Government.

b. Collecting, producing, and disseminating counterintelligence and foreign intelligence, including information concerning groups threatening Third World friends and allies. Within the United States, such activity is coordinated with the Federal Bureau of Investigation via procedures agreed upon by the Director of Central Intelligence and the Attorney General.

8. Department of Justice. The Department of Justice serves as counsel for the citizens of the United States in enforcing the law in the public interest. With respect to overseas matters, the Department of Justice:

a. Plays a key role in protection against criminals and subversion within the United States resulting from insurgent or drug-trafficking groups external to the United States.

b. Drafts legal opinions of the Attorney General, as requested by the President and heads of the executive departments, in matters concerning foreign assistance and support to Third World friends and allies.

c. Prepares and files all applications for surveillance under the Foreign Intelligence Surveillance Act of 1978 and assists Government agencies by providing legal advice

on matters of national security law and policy. Participates in a variety of interagency committees such as the National Foreign Intelligence Council.

d. Serves as a central point of contact for the US Government on legal matters for foreign justice and police ministers, their departments, and foreign judiciaries.

9. Department of the Treasury. The Department of the Treasury has primary responsibility for formulating and recommending domestic and international monetary, financial, commercial, energy, and trade policy. Department of the Treasury activities include:

a. Suppressing domestic trafficking in illegal explosives and firearms through the Bureau of Alcohol, Tobacco, and Firearms.

b. Conducting financial diplomacy with industrial and developing nations and regions.

c. Improving the structure and operations of the international monetary system.

d. Monitoring developments in foreign exchange and other markets and official operations affecting those markets.

e. Overseeing US participation in the multilateral development banks and coordinating US policies and operations relating to bilateral and multilateral development lending programs and institutions.

10. United States Institute of Peace. The US Institute of Peace is an independent, federal, nonprofit corporation tasked to develop and disseminate knowledge about the peaceful resolution of international conflict. Its purpose is to:

a. Provide creative practical insights through research, education, and training on negotiation, mediation, and other skills to those actively engaged in resolving international conflicts.

b. Expand the body of knowledge about the nature of peace, war, and international conflict management.

11. Inter-American Foundation. The Inter-American Foundation is an independent government corporation supporting social and economic development in Latin America and the Caribbean. It responds directly to the initiatives of the poor in Third World nations by supporting local and

private grassroots organizations. These include community associations and small urban enterprises, as well as larger organizations that work with local groups and provide credit, technical assistance, training, and marketing services.

12. African Development Foundation. The African Development Foundation assists and supports indigenous, community-based, self-help grassroots organizations in their efforts to solve development problems throughout the African continent. The organization:

- a. Works to strengthen the bonds of friendship and understanding between the peoples of Africa and the United States.
- b. Supports self-help activities at the local level designed to stimulate community development.
- c. Encourages and assists effective and expanding participation of Africans in their development process.
- d. Encourages the establishment and growth of institutions that can sustain development, are indigenous to the particular country, and that can respond to the requirements of the poor in those countries.

## APPENDIX G

## EXECUTION CHECKLIST

1. Purpose and Scope. This appendix provides the format and procedures for preparing and using an execution checklist for synchronization of a JFSOCC-directed mission (see Chapter V).

2. General. The checklist is prepared as an appendix to the operations annex. The checklist reflects the detailed sequence of events necessary for mission execution according to the approved concept of operations. Therefore, the approved checklist has the effect of an order. Reports rendered in accordance with the checklist keep the JFSOCC informed of the current status of the mission from the launch of the first element to the recovery of the last element.

3. Procedures. The execution checklist is a sequential list of all key actions associated with mission execution and the codewords or alphanumeric characters assigned to each action. As each action is completed, designated personnel transmit the codeword or alphanumeric character over a specified frequency to a specified station, normally the JOC or ABCCC. Some codewords or alphanumeric characters, such as those for an aborted landing or early compromise of the mission, are transmitted only by exception. Other stations in the net monitor all transmissions to obtain operational information. To minimize message transmissions, these stations do not acknowledge any report unless it is directed to them.

a. Events labeled "M" (mandatory) on the checklist require a report when the event occurs or if the event cannot or has not been accomplished as scheduled.

b. Events labeled "X" (by exception) on the checklist require a report only if the event occurs.

c. Reports are rendered by call sign, codeword or alpha-numeric character, and time event occurred (for example, "TANGO 35, THIS IS BRAVO 40, GOOSE AT 2136.").

d. If an event is significantly delayed or not executed according to the checklist, a report is rendered with expected delay time or other pertinent information (for example, "TANGO 35, THIS IS BRAVO 40, GOOSE DELAYED 20 MINUTES," or "TANGO 35, THIS IS BRAVO 40, GOOSE NOT EXECUTED BECAUSE OF ENEMY CONTACT EN ROUTE AT 2124.")

e. Figure G-1 depicts a sample execution checklist that has been simplified for illustrative purposes only.

EVENT NUMBER	DESCRIPTION	TYPE NET	CALL TO	SIGN FROM	CODEWORD	TIME	
						SCHD	ACTUAL
100	SF RECON TM IN POSITION	M CMD	T35	W28	BUZZARD	0145	
101	SEAL TM IN POSITION	M CMD	T35	B40	GOOSE	0150	
102	#1 MC-130 DEPARTS MOB	M CMD	T35	R06	CHICKEN	0200	
103	#2 MC-130 DEPARTS MOB	M CMD	T35	R06	MARTIN	0202	
104	RGR CO TOT	M CMD	T35	C06	EAGLE	0400	
105	AIRDROP ABORTED	X CMD	T35	C06	VULTURE	0400	
106	TARGET SECURE	M CMD	T35	X06	HAWK	0430	
107	TARGET DESTROYED	M CMD	T35	X06	FALCON	0445	
108	ASSAULT REPULSED	X CMD	T35	X06	OSPREY		
109	#1 MH-53 LANDS TARGET	M CMD	T35	D06	ROOSTER	0500	
110	#2 MH-53 LANDS TARGET	M CMD	T35	D08	BLUEJAY	0501	
111	#1 MH-53 DEPARTS TGT	M CMD	T35	D06	CARDINAL	0505	
112	#2 MH-53 DEPARTS TGT	M CMD	T35	D08	ROOSTER	0506	
113	#1 MH-53 LANDS MOB	M CMD	T35	R06	DOVE	0630	
110	#2 MH-53 LANDS MOB	M CMD	T35	R06	RAVEN	0630	

Figure G-1. Sample Execution Checklist

## APPENDIX H

## STANDARD SO MISSION DESIGNATION

1. Purpose and Scope. This appendix provides a convention for assigning discrete SO mission numbers. These numbers are assigned by the JFSOCC and announced in the MITASK. They are used by SO headquarters to track missions.

2. General. The standard format serves two purposes. At the most basic level, it allows an individual to ascertain quickly certain basic aspects of the mission. During heavy activity, this saves time, reduces confusion, and facilitates effective coordination. On a broader level, standardizing mission designation means that "part time" staff augmentees or liaisons do not need to master a different system for each theater SOC.

3. OPSEC. Planning documents listing SO missions should be classified and limited to those with a need to know, as the shifting emphasis in SO activity may foretell other operations (surge of SR in preparation for an advance, for example). Missions within the mainstream of operations may still be masked by a notional designator if necessary. Exceptionally sensitive missions should be compartmented and kept within discrete SPECAT channels.

4. Basic Format. The standard mission designation for SO has three components: mission designator, operational unit designator, and mission support designator. For example, the mission "UW041/ODAl01/ADI010" may be separated as follows:

a. Mission Designator. The first set of characters indicates the type of mission and assigned number. Numbers need not be in numerical order, but they must be discrete. In this example, "UW041" designates unconventional warfare mission number forty-one. Mission codes include:

(1) Unconventional Warfare	UW
(2) Evasion and Escape	EE
(3) Special Reconnaissance	SR
(4) Terminal Guidance	TG
(5) Direct Action (Other)	DA
(6) Foreign Internal Defense	FID
(7) Counterterrorism	CT
(8) Combat Search and Rescue	CS

- |      |                                 |    |
|------|---------------------------------|----|
| (9)  | Psychological Operations        | PO |
| (10) | Civil-Military Operations       | CM |
| (11) | Civil Administration            | CA |
| (12) | Special Operation (Other)       | SO |
| (13) | Coastal Patrol and Interdiction | CP |

b. Operational Unit Designator. This middle set of characters designate the mission's primary executor. In the example, this is Special Forces Operational Detachment A-101. The MPA designates this unit and adds it to the mission designation. Common SOF units include:

- |      |                                     |     |
|------|-------------------------------------|-----|
| (1)  | SF Operational Detachment A         | ODA |
| (2)  | SF Operational Det B (Company HQ)   | ODB |
| (3)  | SF Operational Det C (Battalion HQ) | ODC |
| (4)  | Special Forces Group                | SFG |
| (5)  | Ranger Regiment                     | RAR |
| (6)  | Ranger Battalion                    | RAB |
| (7)  | Ranger Company                      | RAC |
| (8)  | SOA Battalion                       | SAB |
| (9)  | SOA Company                         | SAC |
| (10) | SEAL Platoon                        | PLT |
| (11) | SEAL Squad                          | SQD |
| (12) | SDV Platoon                         | SDV |
| (13) | DDS Platoon                         | DDS |
| (14) | SBU Detachment                      | SBU |
| (15) | Mobile Communications Team          | MCT |
| (16) | Special Tactics Team                | STT |
| (17) | Special Tactics Squadron            | STS |
| (18) | Special Tactics Group               | STG |

(19)	PSYOP Group	POG
(20)	PSYOP Battalion	POB
(21)	PSYOP Company	POC
(22)	PSYOP Detachment	POD
(23)	CA Battalion	CAB
(24)	CA Company	CAC
(25)	CA Detachment	CAD
(26)	Chemical Reconnaissance Det	CRD
(27)	Special Operations Wing/Group	SOW
(28)	Special Operations Squadron	SOS
(29)	Special Operations Detachment	SOD
(30)	Special Operations Element	SOE
(31)	Maritime Vessel	Hull Number
(32)	Individual Aircraft	Tail Number

c. Mission Support Designator. The last set of characters refers to mission support action (infiltration, resupply, exfiltration, etc.). The first three characters are determined during MICON development and are identified by the MPA. The supporting agency provides the remainder of the characters, representing the supporting mission number (normally sequential). In the example, "ADI010" indicates airdrop infiltration mission number ten. Commonly used codes follow:

(1)	Infiltration (Airdrop)	ADI
(2)	Infiltration (Maritime)	MAI
(3)	Infiltration (Airland)	ALI
(4)	Infiltration (Overland)	OLI
(5)	Exfiltration (Airland)	ALE
(6)	Exfiltration (Maritime)	MAE
(7)	Exfiltration (Overland)	OLE
(8)	Resupply (Airdrop)	ADS



(9)	Resupply (Maritime)	MAS
(10)	Resupply (Airland)	ALS
(11)	Resupply (Overland)	OLS
(12)	Air-Sea Rendezvous	ASR
(13)	Tactical Air Support	TAS
(14)	Close Air Support	CAS
(15)	Photo-Recce Support	PRS
(16)	Surface-to-Air Recovery (Fulton)	SRY
(17)	Offshore Sea Recovery/Rendezvous	OSR
(18)	Tactical Electronic Warfare	TEW
(19)	Loudspeaker Broadcast	LSB
(20)	Leaflet Drop	LFD
(21)	Security	SEC
(22)	Mine Search	MIS
(23)	Beacon Emplacement	BTE
(24)	Diver Support	DST
(25)	Logistic Support	LOG
(26)	Armed Reconnaissance	ARC
(27)	Message Pickup	MEP
(28)	Cache Emplacement	CAE
(29)	Airborne Command and Control	ABC
(30)	Air Refueling	ARF
(31)	Ground Refueling	GRF
(32)	Other	OTR

APPENDIX J

SOF LOGISTIC PLANNING CHECKLIST

1. Purpose and Scope. The following checklist provides a tool for logistic planning in support of SOF. It is not all-inclusive and should serve as a point of departure for the planning of SOF support and sustainment. Despite this, the checklist is extremely detailed and may be used to check the thoroughness of any SO logistic support plan. The following paragraphs separate a support plan into its fundamental parts and present questions for evaluating the content.

2. References

- a. Is a listing of doctrinal, policy, and procedural publications, appropriate to the level at which the plan is prepared, provided to assist the logistic operator?
- b. Are there any contingency plans that apply?
- c. Are the necessary maps listed and available?

3. Purpose. Is there a concise statement of the purpose for which the logistic support plan is prepared?

4. General

- a. Does this paragraph provide a summary of the requirements, taskings, and concept of operations that the logistic planning supports?
- b. Are the objectives specified?

5. Assumptions. Does this paragraph list the assumptions upon which the concept of operations and logistic support are based?

6. Responsibilities. Are responsibilities for support clearly stated for the following:

- a. Joint Staff?
- b. USSOCOM?
- c. USTRANSCOM?
- d. Military Services?
- e. Unified commands and their component commands?

- f. Theater special operations commands?
- g. Defense Security Assistance Agency?
- h. Defense Mapping Agency?
- i. Department of State and American Embassies?
- j. Security Assistance Organizations?
- k. Liaison Offices?
- l. Defense Logistics Agency?
- m. Army and Air Force Exchange Service?
- n. Units or elements providing logistic support to SOF components?

7. Concept of Logistic Support

- a. Does this paragraph describe how supply, maintenance, transportation, and field service support will be provided?
- b. Does this paragraph specify which logistic elements will provide the support? Are the forces provided adequate?
- c. Does the planned support complement the tactical plan? Is it adequate and feasible?
- d. Have the terrain and enemy intelligence been analyzed to determine the impact on logistic support?
- e. Has the deployment flow been properly analyzed to determine the time-phasing for introduction of logistic elements to support the combat forces?
- f. Have HNS or FNS availability and subsequent risks been considered?
- g. Has the support of SO-peculiar equipment, materials, supplies, and services been adequately addressed?
- h. Have validation procedures for SO-peculiar equipment, materials, supplies, and services been clearly established?

8. Supply

a. General

- (1) Are the supply system and procedural guidance provided?
- (2) Is the flow of requisitions described?
- (3) Is the flow of materiel described?
- (4) Is a project code required and identified?
- (5) Is a temporary Force Activity Designator (FAD) upgrade required?
- (6) Are in-country DOD Activity Address Codes (DODAACs) required?
- (7) Are ALOC procedures described?
- (8) Is the number of days of supplies required to accompany troops identified?
- (9) Are provisions made for contracting and local purchase support?
- (10) Are the stockage objectives by class of supply specified?
- (11) Will automated or nonautomated procedures be used?
- (12) Will automated systems of supported units and task organized CSS units interface?
- (13) Have the inter-Service support requirements been identified and common, cross-, and joint servicing arrangements coordinated for support of SOF?
- (14) What support will be provided by host-nation or foreign-nation support?
- (15) What in-theater support is required?
- (16) Are retrograde procedures for excess and unserviceable items spelled out?

- (17) What are the provisions for emergency resupply?
- (18) Have initial preplanned supply support and emergency support packages been considered?
- (19) Is the communications capability provided and compatible with the automated systems being deployed?
- (20) Are changes to the DOD Activity Address File required, such as "ship-to" address?
- (21) Are some supply support activities to be designated as ALOC?
- (22) Are procedures described for cancellation or diversion of materiel in-process or in-transit at the termination of the operation or exercise?
- (23) Are provisions made for logistic support of displaced civilians, prisoners of war, and indigenous personnel?
- (24) Is there covered storage in the area of operations to protect supplies from the elements? If not, are shipments packed for outdoor storage?
- (25) Are material handling equipment requirements provided?
- (26) Is sufficient rigging material available for conventional and SO airdrop operations?
- (27) Is the Defense Automatic Addressing System aware of the communications routing identifier and DODAAC to be used for processing direct requisitions and direct supply status?
- (28) Have distribution procedures for maps been addressed?

b. Class I

- (1) Are mess facilities identified and adequate?
- (2) Are the ration cycles described by phase? Is a ration cycle proposed?

- (3) Are fresh eggs, fresh fruits and vegetables, fresh meats, juices, milk, and canned soft-drink supplements to the MRE, T, and B ration meals considered?
- (4) Do local fresh fruits and vegetables meet US standards?
- (5) Have unitized operational rations been considered for ease of handling and accountability?
- (6) Are cash meal payment procedures established?
- (7) What method of distribution will be used (unit distribution or supply point distribution)?
- (8) Are bakery supplements to MRE, T, and B ration meals considered?
- (9) Are veterinary personnel adequate for the subsistence support requirements?
- (10) Are hospital rations required?
- (11) Are chill, freeze, and refrigeration requirements for unit dining facilities and Class I supply point addressed?
- (12) Are water support requirements satisfied?
  - (a) Are the sources of water fresh, brackish, or salty?
  - (b) Is the source of water local systems, surface, or wells?
  - (c) What type of water purification unit is required?
  - (d) Are chillers required?
  - (e) What is the water planning factor in gallons per man per day?
  - (f) What are the treatment, storage, distribution and cooling requirements? Are they satisfied by deploying unit capability?

(g) What are the well drilling requirements? Are there any existing wells? What is the quality of water from existing wells?

(13) Are potable ice considerations covered? What is requirement planning factor? Have the medical planners provided for certification of ice as potable?.

c. Class II

(1) Are requirements for individual clothing and mission-essential consumables addressed?

(2) Have requirements for mission rehearsals and training been identified?

(3) Have provisions been made for the replacement of damaged personal clothing and chemical protective clothing?

(4) Which self-service supply center (SSSC) listing will be used as the basis for the Class II stockage?

(5) How will the logistic support element replenish organizational clothing and individual equipment (OCIE) and SSSC items?

(6) Do any of these items require special consideration?

(a) SO-peculiar materials.

(b) Tentage and tentage repair kits.

(c) Administrative and office supplies.

(d) Folding cots.

(e) Insect bars with mosquito netting.

(f) Banding material and tools.

(g) Water purification chemicals and test kits.

(h) Insect repellent and sun screen.

(i) Field laundry and bath supplies and hospital laundry supplies.

- (j) Dining facility supplies, including paper and plastic products.
- (k) Trash disposal supplies.
- (l) Vector control equipment and supplies.
- (m) Latrine chemicals and supplies.
- (n) Batteries.
- (o) Cold weather clothing and equipment.
- (p) Air conditioners or fans.

d. Class III

- (1) Are Service requirements by location for each type product established?
- (2) Is the use of contractor-provided bulk fuels considered?
- (3) Are ordering and accountable officer requirements addressed?
- (4) Are existing pipeline distribution systems available? What are the pipeline and storage capabilities?
- (5) Are remote refueling sites or FARPs required? What capabilities are required?
- (6) Are inter-Service support billing and reimbursement procedures specified?
- (7) Are POL quality surveillance procedures specified? Are required test kits on hand?
- (8) Is there a petroleum laboratory available?
- (9) Are additives required for commercial fuels? Who will provide them?
- (10) Are any unique package product requirements addressed?
- (11) Are industrial gasses addressed?



e. Class IV

- (1) Are unique requirements for construction, security, and rehearsal materials addressed?
- (2) Is in-country procurement considered?
- (3) Have Class IV data sources been queried on pre-existing data bases describing locally available construction materials?
- (4) Are basic loads to be deployed?
- (5) Will the use of pre-positioned materiel stocks be permitted?

f. Class V

- (1) Are unit basic loads to be deployed?
- (2) Is the logistic support structure prescribed?
- (3) Are EOD support requirements and procedures addressed?
- (4) Are SO-peculiar ammunition requirements addressed?
- (5) Have the storage, handling, shipping, security, and safety requirements been reviewed and addressed in the planning?
- (6) Are requirements identified by category of munitions?
- (7) Are sustaining rates of munitions addressed?
- (8) Are special permits needed? Who issues them?

g. Class VI

- (1) Are the deploying personnel provided guidance on personal demand items?
- (2) Are sundry packs available?
- (3) Is indirect or direct exchange support considered?

(4) If exchange support is required:

(a) Has Headquarters AAFES (Plans) been notified?

(b) Have the exchange staffing, stock assortment, security, facility, transportation, and communications requirements been identified and coordinated?

(c) Is finance support for the exchange identified?

(d) Has the policy on rationing and check cashing been determined?

h. Class VII

(1) Are SO-peculiar equipment requirements identified and validation procedures established?

(2) Does the plan specify the equipment fill level for deploying units?

(3) Are equipment redistribution (cross-leveling) requirements specified?

(4) Are replacement actions for salvage equipment specified?

(5) Are operational readiness float requirements addressed?

i. Class VIII

(1) Are medical supply procedures prescribed?

(2) Does this portion of the logistic support plan complement the medical support plan?

(3) Are medical resupply procedures established?

(4) If applicable, are policies concerning medical treatment of non-US personnel provided?

(5) Are special medical equipment and supply requirements identified based on medical mission and the area of operations?

(6) Are memorandums of understanding established with medical logistic providers to ensure these medical supplies are stored, maintained and ready to meet all operational contingencies?

(7) Are special storage requirements satisfied?

(8) Is the disposal of salvage medical supplies addressed?

(9) Are medical oxygen and other medical gases requirements such as anesthesia identified and resupply procedures established?

(10) Is local purchase an option? Are procedures and guidelines established?

j. Class IX

(1) Are SO-peculiar repair requirements specified?

(2) Are common repair parts requirements, including repairables, specified?

(3) Are cannibalization procedures addressed?

(4) Are requirements for nonexpendable components addressed?

(5) Is stockage of major assemblies addressed?

(6) Have special storage requirements been addressed for dry batteries, classified repair parts, high dollar pilferables, etc.?

(7) Is disposal of hazardous materials, such as lithium batteries and radioactive residue, specified?

k. Class X

(1) If Class X materials are required, does the plan describe the source?

(2) What is the source of funding for Class X supplies?

9. Maintenance

- a. Does the plan describe how unit, intermediate (direct support/general support), and SO-peculiar equipment maintenance will be performed?
- b. Is missile maintenance support required and available?
- c. Does the plan address calibration requirements?
- d. Is maintenance exchange addressed?
- e. Have extreme weather aspects been considered (e.g., heat, cold, humidity, dust)?
- f. Are site security and storage requirements identified?
- g. Are special power requirements for maintenance facilities identified (e.g., voltage, phase, frequency, stability, and anticipated load in KW)?
- h. Are building suitability screening factors identified by type of maintenance facility (e.g., minimum height and width for doors, floor load bearing requirements, environmental control necessities)?
- i. Are operational readiness floats addressed?
- j. How will repairs under warranty be performed in the area of operations?
- k. Is the evacuation of unserviceable repairables addressed?
- l. Have procedures for replacing maintenance tools and equipment been specified?

10. Transportation

a. General

- (1) Is there a requirement for expedited cargo distribution to the area of operations?
- (2) Are the transportation support systems for supply distribution and ALOC validation procedures outlined?

- (3) Have MHE requirements been addressed?
- (4) What is the availability of USTRANSCOM, DIA, or DMA data analysis regarding the country transportation infrastructure, to include ports, airfields, roads, railroads, and inland waterways?
- (5) Is there a rail system available? What are schedules and capability?
- (6) Is the highway net described? What are the capabilities and limitations?
- (7) What is the weather impact on ports, airfields, and highway nets?
- (8) Are in-country highway, rail, air, and inland waterway mode requirements addressed?
- (9) Are the transportation movement priority and transportation account codes provided? Are transportation funding procedures established?
- (10) Has a dedicated in-country, intratheater, or intertheater movement system for personnel and high-priority cargo been established?
- (11) Has coordination been made with USTRANSCOM for personnel and equipment movements?
- (12) Has the use of foreign flag carriers been addressed?
- (13) What agency will accept and coordinate administrative transportation requirements for SOF?
- (14) What HNS support is available?
- (15) Have medical evacuation requirements been included in the planning?

b. Airfields

- (1) What airfields are available to support military operations?
- (2) Has a coordinating headquarters been designated for all airlift support?

- (3) Has support been planned for USAF mobile aeromedical staging facilities?
- (4) What are the personnel and cargo reception capabilities of the APOE and APOD?
- (5) What is the current usage of the airfield?
- (6) What are the characteristics and capabilities of the roads that access the airfield?
- (7) What contract civilian or HN personnel and equipment assets are available to assist at the APOD and APOE?
- (8) Has an Arrival/Departure Airfield Control Group (A/DACG) organization been designated? Have Aerial Port Squadron and/or Airlift Control Element requirements been identified?
- (9) What airfield facilities are available for military use during A/DACG operations?
- (10) What is the best source for additional information on the airfields?
- (11) Have channel airlift requirements been specified?
- (12) Have airbase defense requirements been properly addressed?

c. Supply Routes

- (1) What are the road movement and convoy restrictions?
- (2) What routes are available to support military operations?
- (3) What are the characteristics and capabilities of the routes available to support military operations?
- (4) What are the dimensions and classifications of tunnels and bridges along the routes?
- (5) What capabilities exist to repair damaged segments of routes?

(6) What segments of the routes are heavily used by the civilian populace?

(7) What are the most likely routes fleeing refugees would use?

(8) Are traffic control measures in-place?

(9) What is the best source for additional information on the routes?

11. Field Services

a. Are laundry, bath, clothing renovation, and latrine requirements addressed? Local sources?

b. Are graves registration and mortuary capabilities adequate to support the anticipated requirements?

c. Are procedures for salvage collection, evacuation, and disposal covered?

d. Are Base/Post Exchange services required and provided?

e. Is fire protection provided for aviation, ammunition, and bases?

f. Are procedures for waste disposal addressed?

g. Are field bakery services required and provided?

h. Are procedures specified and do units have the equipment necessary for cleaning of equipment for redeployment to meet customs and agriculture requirements to enter the CONUS?

12. Miscellaneous

a. Have billeting and support requirements at ISBs and FSBs been addressed?

b. Are HN military personnel with experience in US military schools identified?

c. Have arrangements been made with US and HN customs and immigration?

d. Are procedures for logistic reporting established?

- e. Is delousing support required?
- f. Are isolation or rehearsal facilities required?
- g. What are the funding aspects of logistic support?
  - (1) Have all requirements been costed?
  - (2) Has an Account Processing Code been established?
  - (3) Have SO-peculiar equipment resourcing procedures been identified?
- h. What is the electrical power cycles of the country? Are transformers required?
- i. Are printing and duplicating requirements identified?
- j. Are the communications to support logistic operations provided for in the communications planning? Telephone?
- k. Have requirements for aerial delivery, personal parachutes, and air items been identified?
- l. Is a source of liquid oxygen required?
- m. Have diving-support requirements been addressed?
- n. Have administrative-use vehicle requirements been identified?
- o. Are audio-visual requirements identified?
- p. Have communication frequencies been cleared with the HN government?
- q. Are there adequate provisions in the plan for contracting support?
  - (1) Has an adequate number of contracting officers with the proper warrant been provided?
  - (2) Is adequate finance support available?
  - (3) Is adequate legal support available?
  - (4) Is adequate linguist support available?



(5) Are there provisions in the plan for maneuver or war damage claims resulting from logistic operations?

r. Are automated logistic systems procedures properly addressed?

(1) Have backup master files been established and prepared for shipment separate from the primary master files?

(2) Are maintainers, operators, and managers assigned and well trained?

(3) Have site selection and preparation for automated equipment considered accessibility, geographic, terrain, and security requirements?

(4) Is there a continuity of operations plan?

(5) Are sufficient copies of user manuals on hand and current?

(6) Are sufficient repair parts available for the computer hardware, including generators and other subsystems?

(7) Have provisions been made for backup support for repair parts, hardware maintenance, and the receipt of software change packages?

(8) Has telephone support been arranged?

(9) Have details been worked out for transmission of documents to higher and lower echelons?

(10) Will customer units require training? Are customer user manuals available for automated system support?

s. Have OPSEC requirements been integrated into logistic planning? Has the logistic signature been minimized?

t. Have security police requirements for SO bases, facilities, training areas, rehearsal sites, and storage sites been identified and resourced?

## APPENDIX K

## OTHER FORCES TRAINED AND EQUIPPED TO SUPPORT SO

1. Purpose and Scope. This appendix reviews conventional forces that receive enhanced training so that they may better support certain SO. These forces come from the Active or Reserve Navy, Army, Air Force, and Marine Corps.

2. General. Certain conventional forces receive enhanced training and special equipment that make them uniquely qualified to support SO. Some may be earmarked to support SOF by command agreement arrangements or documented as augmenting forces in plans. They are not designated as SOF by the SecDef, although the Marine Corps designates the MEU as "SO-capable." On a mission-specific basis these units may be assigned to support SO or participate in joint SO training. In some cases, these supporting forces augment existing SOF capabilities. The following paragraphs describe these forces and their capabilities and limitations.

3. US Air Force

a. Airlift Special Operations Low-Level. Airlift SOLL II C-130, C-141 and C-5 aircraft, by virtue of special aircrew training and/or aircraft modification, can quickly augment core SOF for the conduct and support of selected SO. They frequently practice single-ship tactical operations along SO profiles, maintain proficiency with night vision goggles, and participate in joint SOF exercises. The SOLL I program has been converted into the conventional Pathfinder program.

b. Tankers. The Air Mobility Command and Air Combat Command maintain a limited number of strategic tanker crews trained to support the often unique refueling requirements of SO fixed-wing aircraft.

4. US Navy

a. Helicopters. Helicopter Combat Support Special Squadrons 4 and 5 of the Naval Reserve operate HH-60H aircraft for either extended remote site operations ashore or extended shipboard operations. The aircraft are configured to support SOF infiltration and exfiltration. These units:

- (1) Plan and execute missions during the hours of darkness. Routes are planned to avoid acoustic, optical, or electronic detection. Navigation requires visual meteorological conditions and is aided by global positioning system and doppler radar.

(2) Train for single and multi-ship operations, to include dissimilar rotary wing aircraft types. Aircrews maintain NVG qualification.

(3) Operate aircraft equipped with secure radios; zone suppression weapons (M-60D and programmed GAU-17); NVG-compatible lighting (interior and exterior); air rescue personnel locator system (PLS); radar and IR self-protection capability; and automatic approach, hover, and depart capability. A cargo hook permits external cargo movement. Capability is similar to the MH-60G, except that it lacks aerial refueling.

(4) Self-deploy over 500 nautical miles. They have a combat radius of 250 nautical miles with a crew of 4 and 8 passengers. They are also certified for C-5 transport and are compatible with any RAST-configured surface combatant, any air-capable amphibious ship, and aircraft carrier.

b. Submarines. There are two types of submarines specially configured to accommodate the Dry Deck Shelter (DDS) and support submerged or surface launch and recovery of SOF personnel, equipment and SDVs. Most other submarines can support dry or wet deck launches or submerged lock-in/lockout for SOF personnel and equipment.

## 5. US Marine Corps

a. Marine Expeditionary Unit (Special Operations Capable). The MEU(SOC) is organized, trained, and equipped in a manner that makes it capable of performing certain SO missions when it is the most opportune force available. MEU(SOC) capabilities can complement the DA or CT missions of SOF. The MEU(SOC) trains to operate in all environments and weather conditions (night, adverse weather, urban terrain) under emissions control (EMCON) conditions and at extended ranges. Elements of the MEU(SOC) practice entry, clearing, and quick-fire techniques along with more conventional skills. Specific capabilities related to SO include (see the Marine Corps Capabilities Plan and MCO 3120.8A for further discussion):

(1) Tactical recovery of aircraft, equipment, and personnel in a nonpermissive environment.

(2) Specialized demolition operations. This includes an explosive entry capability to facilitate close quarter combat and dynamic assault tactics and techniques.

- (3) In-extremis hostage recovery operations.
- (4) Clandestine reconnaissance and surveillance.
- (5) Seizure and destruction of offshore gas and oil platforms.
- (6) Close quarter battle.

b. Maritime Special Purpose Force. The MSPF is task organized from within MEU and PHIBRON assets to provide a force that can be quickly tailored to accomplish a specific mission as a complement to conventional naval operations, unilaterally, or in support of joint SO. OPCON of the MSPF remains with the MEU commander; however, the JFC may pass OPCON of the MEU to the JFSOCC. Generally, the MSPF is composed of a command section; a covering unit consisting of one or more rifle companies heliborne or on standby aboard ship; a strike unit organized to conduct on-scene reconnaissance, security, assault, command, and support functions; and an aviation support unit to provide assault support, close fire support, and close air support. The MSPF is not designed to duplicate existing SOF capabilities.

- (1) ... estimate message recovery operations
- (2) ...
- (3) ...
- (4) ...
- (5) ...
- (6) ...

... The MRR is task ...  
 ... within MRR and ...  
 ... to provide ...  
 ... to accomplish ...  
 ... as a complement to conventional ...  
 ... of point ...  
 ... MRR commander ...  
 ... MRR to the ...  
 ... composed of a command ...  
 ... consisting of one or more ...  
 ... strike ...  
 ... reconnaissance ...  
 ... and support functions ...  
 ... provide assault support, close ...  
 ... support. The MRR is not ...  
 ... SOF capabilities

(INTENTIONALLY BLANK)

APPENDIX L

PSYCHOLOGICAL OPERATIONS

1. General. PSYOP are planned operations to convey selected information and indicators to foreign audiences to influence their emotions, motives, objective reasoning, and ultimately the behavior of foreign governments, organizations, groups, and individuals. The purpose of PSYOP is to induce or reinforce foreign attitudes and behavior favorable to the originator's objectives.

a. Intermediate and ultimate target audiences are analyzed and selected based on their likely effectiveness in generating a desired behavior. Foreign key communicators and media are termed intermediate audiences as their function is to transmit a message, not to act upon it. Intermediate target audiences are analyzed and selected based on their likely effectiveness in generating the desired behavior in the primary target audience and may not be aware that they are targeted and are supporting US objectives. HN populace, insurgents, and hostile forces are customarily selected as primary target audiences as the result of extensive information collection, intelligence, research, and analysis.

b. By law, PSYOP will not be directed at US targets.

c. PSYOP is a force multiplier. SOF planners at all levels must know PSYOP capabilities and integrate PSYOP into their flexible deterrent options and force packages. Early employment is the key to PSYOP success.

d. PSYOP plans and themes are approved by the NCA as part of a coordinated international information strategy at the interagency level. As part of that strategy, PSYOP may be strategic, operational, tactical, or consolidation:

(1) Strategic PSYOP are conducted on a global or regional basis to support the achievement of national or theater strategic objectives.

(2) Operational PSYOP are conducted in a defined geographic area to promote the effectiveness of an area commander's campaigns and strategies.

(3) Tactical PSYOP are conducted in the area assigned a tactical commander to support the tactical mission.

(4) Consolidation PSYOP are conducted in foreign areas under friendly control to influence the behavior of the foreign populace in support of friendly objectives in the area.

2. Interagency Coordination. Military PSYOP is a projection of US foreign policy. As such, these operations must be conducted in concert with the actions of other Government agencies. DOD Directive S-3321.1 implements integration of overt peacetime PSYOP programs and international information as required by National Security Decision Directive 130. The theater overt peacetime PSYOP program is critical to training PSYOP forces in peacetime and provides a necessary backdrop to employing PSYOP in support of contingency operations.

3. Inter-Service Coordination. Conduct of PSYOP is a joint endeavor. Certain PSYOP activities require delivery assets of one Service to disseminate the PSYOP product of another Service. An example would be the use of Air Force SO air assets to disseminate Army-produced leaflets. Joint PSYOP missions require the coordinated expertise of the different Services.

4. Intelligence Support to PSYOP. PSYOP requires intelligence support (FM 33-5, Appendix I, provides an extensive list of specific priority intelligence requirements for PSYOP). Specific guidance for intelligence support to PSYOP is listed in USSOCOM Intelligence Baseline Document and Objective Architecture Document. PSYOP intelligence falls into three categories: target audience, issues and themes, and means of dissemination. PSYOP assets can provide intelligence support to SO from basic PSYOP studies, special PSYOP analyses and special PSYOP studies. These studies contain data about people that can be useful in SO team preparation. This information can be obtained from the supporting PSYOP unit.

5. PSYOP Planning Considerations. To assist planning PSYOP support for other SO, the JFSOCC may request support from the theater if he does not have the appropriate expertise within the SOC. PSYOP normally supports other SOF as shown below:

Supported SOF Organization  
Theater SOC  
Special Forces Group  
Special Forces Battalion or  
Operational Detachment  
JSOACC (AFSOC)

Supporting PSYOP  
PSYOP Staff Element  
PSYOP Detachment  
PSYOP Element  
PSYOP Staff Element  
and/or LNOs

The size and composition of these detachments and elements vary according to the type of SO mission. PSYOP forces provide PSYOP-specific planning through their knowledge of PSYOP capabilities, limitations, and potential target audiences.

6. PSYOP Capabilities in Support of Other SO

a. Direct Action

- (1) Prepare the target population for the introduction of US SOF into its country.
- (2) Assist in tactical cover and deception operations.
- (3) Encourage enemy surrender and civilian noninterference with operations.

b. Counterterrorism

- (1) Counter the terrorist message.
- (2) Ease public apprehension about the terrorist threat and assure them that effective measures are being taken to counter the threat.
- (3) Inform target audience of terrorist goals, leaders, and infrastructure.
- (4) Expose terrorist propagandists and sympathizers as agents of the terrorists themselves to degrade their credibility.
- (5) Provide incentives to local populace to inform on terrorist groups.
- (6) Gain indigenous support for friendly CT forces and actions.
- (7) Develop programs to persuade terrorists that responsible governments will not negotiate with them.
- (8) Undermine terrorists' morale and confidence in their leadership while demonstrating the futility of their cause.
- (9) Divide and undermine terrorists support structure.
- (10) Publicize the roles of nations supporting terrorism.



c. Foreign Internal Defense

- (1) Integrate PSYOP into all aspects of foreign assistance programs, including internal development.
- (2) Develop programs to inform the international community of US intent and good will.
- (3) Assist the HN in gaining the support of its people.
- (4) Assist the HN in defeating the insurgents by shifting the loyalty of opposing forces and their supporters to the HN government.
- (5) Project a favorable US image in the HN.
- (6) Favorably influence neutral groups and the world community.
- (7) Assist the HN in establishing defector rehabilitation programs.
- (8) Provide close and continuous PSYOP support to maximize the effect of civil-military operations.
- (9) Establish HN command support of positive population control and protection from insurgent activities.
- (10) Provide area assessments.

d. Special Reconnaissance

- (1) Project a favorable image of the United States.
- (2) Prepare the population for introduction of US SOF into their country.
- (3) Provide analyses of key leaders and groups in the target area as far as influencing them and eliciting responses favorable to the United States.

e. Unconventional Warfare

- (1) Exploit the potential that exists for a resistance movement.
- (2) Inform resistance elements hostile to the government that US policy forbids US forces to be aligned with insurgent movements that embrace strategies, techniques, or tactics that involve

murder, assassination, inhumane treatment of prisoners, or violations of civil rights.

(3) Advise SOF on the psychological impact of planned operations.

(4) Show that social, political, and human rights goals of the resistance movement and those of the population are the same.

(5) Create doubt in the minds of enemy sympathizers that the enemy insurgency can prevail and instill fear in them that their continued support of the enemy could result in their future punishment.

(6) Let enemy sympathizers know that the resistance is aware of who they are and initiate steps to discredit them.

(7) Reduce the enemy's will to fight; persuade them to desert, surrender, or malingering.

(8) Help convince enemy forces that their cause is unjust and immoral.

(9) Help ensure the continued support, active participation, and recruiting efforts of resistance forces.

## 7. Limitations

a. The employment of some PSYOP assets requires the supported SOF commander anticipate requirements well before deployment.

b. Enemy countermeasures may negate desired effects.

c. Incomplete intelligence may impair message or theme effectiveness.

d. Limited accessibility of target audiences may degrade PSYOP effectiveness.

e. Terrain and weather conditions may affect some PSYOP dissemination assets.

8. PSYOP Target Audiences. PSYOP themes and messages can be effective in influencing the behavior of target audiences in SO. The lists below show which target audiences PSYOP can influence in support of each SO primary mission.

PSYOP Target Audience

Supported SO Mission

Hostile Combatants	DA, FID, UW
Hostile Rear Echelon	DA, FID, SR, UW
Hostile Sympathizers	CT, FID, SR, UW
Other Belligerents	DA, CT, FID, SR, UW
Nonbelligerents	DA, CT, FID, SR, UW
Friendly Combatants	FID, UW
Friendly Civilians	DA, FID, CT, UW
Hostile Civilians	DA, CT, FID, SR, UW
Key Communicators	DA, CT, FID, UW
Special Interest Groups	DA, CT, FID, UW

## APPENDIX M

## CIVIL AFFAIRS

1. General. Civil affairs are an inherent part of military operations and support resolution of the commander's legal and moral obligations to the indigenous populace. CA can significantly enhance the success and acceptance of SOF missions. CA provides advice and assistance for coordinating and executing civil assistance, public health and safety, dislocated civilian control, humanitarian aid, and other related areas. The theater combatant commander may choose to exercise OPCON of assigned and attached CA forces through a subordinate JFC or Service component commander, normally the Army component commander. Access to CA forces is coordinated through the theater combatant command staff or USSOCOM J9, as appropriate.

2. Planning Considerations. The theater JFSOCC will forward requirements for CA assets to the theater combatant commander as far in advance as possible, allowing sufficient lead time to call Reserve component CA forces into play. In addition to operational CA assets, the JFSOCC may request CA staff augmentation to enhance planning and coordination. CA units are organized for different missions, including general support and FID/UW. For contingencies, a JSOTF would typically be supported by a regionally oriented company from the Active component CA battalion. CA support to SO includes planning support, pre-deployment support, combat support, and post-combat support.

3. CA Capabilities in Support of Other SOF. CA assets provide advice and assistance to planning and marshaling civilian resources to facilitate military operations. They advise and guide supported commanders with respect to the impact that political, informational, social, economic, and cultural aspects of the area of operation have on military operations and, conversely, that military operations have on the civilian populace. They also enhance working relationships between US forces and HN military or civilian authorities and other nongovernmental agencies. Certain CA units have the mission to employ specialized, regionally orientated, and language qualified CA teams to train, advise, and assist US and indigenous forces in the conduct of civil-military operations that support SO. These CA units are designed to exploit hostile political, social, cultural, and ideological weaknesses. They provide advice and assistance to indigenous military forces to plan and conduct civic action programs that are integrated into national internal development strategies and the operations of passive civilian surveillance networks. These units are characterized by their members' depth of understanding of the

dynamics of the societies in which they operate. The primary target of these units is the vital link between the civilian populace and hostile power. CA support to other SOF include:

a. Planning Support. CA personnel support SOF planning by identifying the SOF commander's legal obligations, recommending the required level of CA support for the mission, and providing expertise regarding the region.

b. Predeployment Support. CA support includes interpreting rules of engagement, identifying sources of foreign area and HN assistance (supply, labor, services, etc.), coordinating HN government external security, and providing area orientation briefings.

c. Combat Zone Support. CA personnel can provide additional language or regional expertise and also focus on controlling and safeguarding civilians, minimizing civilian interference, securing EEI from civilian sources, and identifying VIP or high level political figures.

d. Postcombat Support. Following operations, CA assists in the coordination and execution of a nation building plan for the full restoration of the HN government and public services.

4. Specific Application to SO Missions. Although CA expertise can be applied to planning and area orientation for all missions, CA involvement should be incorporated into planning for FID, UW, and DA missions.

a. Foreign Internal Defense. Assist other SOF, indigenous forces, and host government agencies in planning and executing population and resources control, civic action security and clearance operations, and other initiatives aimed at achieving political mobilization and internal stability. Contact and coordination are made with the host country populace, government and nongovernmental infrastructure. CA activities vary with the capabilities of the HN government and with the level of insurgent activity. Effective CA activities mobilize the civil population in support of the HN government programs. Specific CA objectives are to:

(1) Improve the capabilities of the HN government through civic assistance.

(2) Assist the HN government in mobilizing and motivating its citizens to support their government and military forces.

(3) Assist in planning, coordinating, and executing population and resource control and other security and developmental programs.

b. Unconventional Warfare. CA forces provide support to assist, advise, and train other US SOF and indigenous resistance forces in planning and execution of population and resources control, civic action, political mobilization, civil administration, and infrastructure development aimed at expanding their legitimacy within contested areas.

c. Direct Action. Advise and assist other US SOF and US intelligence elements in joint targeting and mission planning relating to civilian contacts and control, area assessments, rules of engagement, and compatibility between operational and postcombat objectives.

5. CA Limitations

a. CA forces have limited accessibility to the local populace in some environments, particularly UW.

b. CA forces conducting small team operations have limited equipment and rely on the supported command for support.

c. The Active component CA force is one battalion. Its ability to respond is conditional on existing deployments in support of worldwide commitments.

d. CA activities often require extensive interagency coordination.

e. US Army Reserve CA availability for missions augmenting or assumed from the Active component CA force is limited in conditions short of mobilization or when activation under Presidential Reserve call-up authority is infeasible or undesirable.

(INTENTIONALLY BLANK)

## APPENDIX N

## LEGAL ASPECTS OF SPECIAL OPERATIONS

1. Purpose and Scope. The sensitive nature of many SO, the peacetime environment in which many SO activities take place, and the unconventional methods frequently employed in SO, raise many legal issues. This appendix reviews some of these and offers a list of references for more thorough study.

2. General. All SO activities must be planned and conducted in accordance with domestic and international law. Legal constraints applicable to conventional operations generally apply to SOF and may not be relaxed solely to enhance the feasibility or utility of SO. SO that are inconsistent with domestic or international law, or policies of higher authority, can undermine necessary public and political support for US policy and programs and the confidence of DOD components and other Government agencies in the SOF community. However, the tactical effectiveness of SOF should not be jeopardized by imposing unnecessary restraints on SOF commanders. Legal review of SO planning is essential to achieving a balance between tactical effectiveness and legal and policy restraints. Active participation by legal advisers in the planning, preparation, support, and execution of SOF missions will facilitate compliance with complex legal requirements, while preserving as much freedom of action to the commander as possible. Judge advocates who support SOF, and those who support conventional commanders who employ such forces, must provide timely and reliable advice in all relevant areas of operational law. Commanders must recognize the increasingly pervasive influence law and policy have on the shaping of all military operations.

3. Planning. Broad-based legal review of SO should be conducted as early in the planning stage as possible. The review should take account of the legal implications of all foreseeable contingencies. The judge advocate should review the plan for consistency with all applicable laws and regulations, including not only the most obvious (for example, rules of engagement and the law of armed conflict) but also the most specialized (for example, fiscal and environmental requirements, or the need for a Presidential finding). To the maximum extent possible, potential conflicts between law and operations must be identified and resolved in advance so that the SOF commander is not forced to choose between infringing the requirements of law or policy or settling for less than successful mission accomplishment. Such situations should occur infrequently, if ever, given tactically astute, legally sensitive planning and coordination and the exercise of legally responsive C2.



4. Peacetime Considerations. SO missions span the operational continuum. The degree of flexibility within the law and directives varies along the continuum. The laws and directives that apply to operations during peacetime are generally more complex and comprehensive than those that apply during war. Some legal restraints may apply only during peacetime and some only during war. Others apply only in the United States, overseas, or in certain countries. The application of many legal principles is so fact-specific that only the most general guidance can be given in a publication of this nature. Familiarity with the references listed at the end of this appendix will facilitate legal review of operational planning and help answer questions that might arise during SO. AFR 28-3 contains a short checklist, and Annex AS6-3 of NWP-9 contains an extensive one. However, checklists cannot substitute for review of operations by experienced attorneys and operational planners.

5. Unique Aspects of SO. In addition to the many variables discussed above, SO frequently involve legal issues not routinely encountered in conventional operations. Particular attention to these areas is warranted to ensure that vital working relationships with other agencies, DOD components, and foreign governments are preserved and that new restrictions are not imposed on SOF. Examples of legal issues that may be encountered frequently in dealing with SO include, but are not limited to, the following:

- a. Intelligence activities addressed in Executive Order 12333.
- b. Coordination of CT activities in the United States with the FBI as lead agency and overseas with the DOS as lead agency.
- c. The prohibition of direct participation in law enforcement activities while providing assistance to civilian law enforcement agencies during counterdrug operations and other policy-based restrictions in this area.
- d. The statutory authority (10 USC 2011) to use SOF operations and maintenance funds to train foreign forces, where the conduct of such training prepares SOF to perform validated SOF missions.
- e. The use of MFP-11 funds administered by USCINCSOC.
- f. The proper distribution of authority and responsibility for SOF within the Department of Defense under the provisions of 10 USC 167.

g. The authority, responsibility, and procedures for approval, coordination, oversight, and reporting of SO intelligence activities and the management of Special Access Programs.

h. Procedures in DOD Directive S3321.1 for the coordination of PSYOP.

i. International agreements concerning theater search and rescue activities.

j. Legitimate sources of funding for humanitarian and civic assistance.

k. The entitlement of SOF to POW status under the Geneva Conventions. Concern over POW status might justify a request for appropriate modifications to the rules of engagement for such operations.

## 6. References

a. Executive Order 12333, "United States Intelligence Activities."

b. DoD Regulation 5240.1-R, "Procedures Governing the Activities of DoD Intelligence Components That Affect United States Persons."

c. DoD Directive 5525.5, "DoD Cooperation with Civilian Law Enforcement Officials."

d. JCS SM-846-88, "Peacetime Rules of Engagement for US Forces."

e. The Judge Advocate General's School, "U.S. Army, Operational Law Handbook."

f. The Judge Advocate General's School, "U.S. Army, Operational Law (OPLAW) Deployment Checklist."

g. U.S. Army War College, Center for Land Warfare, "Theater Planning and Operations for Low Intensity Conflict Environments."

h. FM 27-10, "The Law of Land Warfare."

i. DA PAM 27-161-2, "International Law, Vol II."

j. DA PAM 27-1, "Treaties Governing Land Warfare."

k. NWP 9, FMFM 1-10, "The Commander's Handbook on the Law of Naval Operations."

l. AFP 110-31, "International Law--The Conduct of Armed Conflict and Air Operations."

m. AFP 110-34, "Commander's Handbook of the Law of Armed Conflict."

n. AFR 28-3, "USAF Operational Planning Process."

## APPENDIX O

## HEALTH SERVICE SUPPORT

1. Purpose and Scope. This appendix provides an overview of the nature and requirements of HSS to SOF in general, and to the complexity of medical planning at the JFSOCC level in particular. The basic joint doctrine for HSS in joint operations is discussed in Chapter III of Joint Pub 4-02. The following discussion presents the functions of HSS, the levels of HSS available through SOF channels, and the need for energetic coordination with theater medical forces. The detail of this appendix exceeds that of other support discussed in the publication and is intended to fill a doctrinal void.

2. General. The nature of SOF medicine presents special problems to the SOF medical planner. Regardless of mission or the level of medical threat, the SOF medical planner must provide all nine functions of HSS. The following paragraphs discuss these HSS functions as they apply to SOF.

3. Evacuation. Medical planners must provide a sound plan for medical evacuation of casualties from point of injury to an appropriate medical treatment facility. The most desirable means of evacuation is by dedicated medical evacuation aircraft; however, OPSEC and operational requirements often dictate the use of nonmedical aircraft. Ground evacuation should be limited to the vicinity of operational bases (i.e., local training areas and rehearsal sites).

a. Intratheater Evacuation. In a mature theater with an established HSS system, SOF should maximize use of the established evacuation system. In an immature theater, or when operational considerations dictate, the medical planner must be opportunistic and prepared to use SOA or other available platforms from the operational or logistic air flow. In these cases, the medical planner must attempt to provide medical care en route so as not to degrade the ground forces' medical support. Medical personnel accompanying the aircraft should come from operational base assets. Intratheater evacuation may require the use of organic SOF aircraft and resources, non-SOF aircraft (C-130, C-141, UH-60, etc.) configured for medical evacuation and/or deployment of elements of the USAF aeromedical evacuation system. The theater aeromedical evacuation system normally operates from forward C-130 resupply airfields and can use either retrograde or dedicated airlift. Coordination to obtain USAF aeromedical evacuation support is normally made through the JFSOCC air operations cell to the AFFOR air

operations center (AOC). Depending on the operational situation and other theater requirements, an aeromedical evacuation liaison team could be deployed with SOF to provide an organic communications capability to coordinate SOF aeromedical evacuation requirements. Alternatively, a mobile aeromedical staging facility (MASF) could deploy with SOF to provide supportive care. A MASF is not intended to hold casualties for longer than 2-6 hours. MASFs are normally sited near runways or taxiways of airfields or FOBs used by tactical airlift aircraft to resupply combat forces.

b. Medical Evacuation Policy. The medical evacuation policy establishes the maximum noneffective period in days that patients may be hospitalized or convalesce within the theater. Casualties will be evacuated from the theater if they cannot return to duty within this period. The evacuation policy can vary from 0 days when there are no in-theater assets, to 90 days or longer when a conventional HSS system is fully established. Convalescing SOF personnel may be able to perform light duties at the support base that will facilitate reconstitution of their teams. SOF may require a separate evacuation policy to prevent personnel with critical specialties from being evacuated out of theater. Generally, the SOF evacuation policy in a developed theater should be longer than that for conventional forces. Proposed policy must be submitted through SOF command channels to the theater combatant commander for approval. The receiving MTF must also be informed. Concurrent coordination with the theater command surgeon is required. In an immature theater, the SOF medical planner must base the recommended evacuation policy on the mission, the assets that will be available to the operational area, available host-nation or third-nation medical treatment facilities, proximity to CONUS, and availability of evacuation resources.

4. Hospitalization. SOF must rely on the conventional HSS system for definitive health care. Even in undeveloped theaters, the SOF planner must coordinate with the appropriate medical channels for support of SOF and accompanying combatant indigenous personnel. The planner should request that the theater command surgeon designate specific facilities where SOF casualties will be taken. He must coordinate for a limited surgical resuscitation and holding facility at the support base (if necessary, a tailored package for sole support of SOF), organic air assets when USAF or Army medical evacuation resources cannot be employed for operational reasons, and USAF aeromedical evacuation assets for transportation to designated MTFs within the theater or to another theater or CONUS. (The MTF

will be designated by the Armed Services Medical Regulating Office or Joint Medical Regulation Office, depending on the nature and OPSEC requirements of the operation. A surgical resuscitation recovery and holding capability is provided to SOF by the 528th SOSB.)

5. Combat Stress Control. Undetected combat fatigue in a SOF team member could jeopardize the mission and welfare of the entire team. Although mental health professionals are assigned to SOF, they do not normally deploy with mission personnel; therefore, they are not available to prevent or treat combat fatigue cases. Debilitating stress is not unique to DA missions. Extended FID and UW missions create stress because they normally involve lack of sleep, food and water deprivation, poor hygienic conditions, infrequent communications with friendly outside sources, and other conditions that impinge on basic human needs. The medical planner must coordinate with the theater surgeon for on-site or advisory support. Lacking in-theater sources, arrangements must be made to evacuate combat fatigue casualties to appropriate MTFs. The two principles of stress control are early identification and treatment as far forward as possible. Treating casualties as far forward as possible hastens return to duty, conserves evacuation resources, and precludes unnecessary loss of personnel. Historically, evacuated stress casualties are far less likely to rejoin the unit.

6. Health Service Logistics and Blood Management. Medical logistics includes not only common medical supplies but also oxygen, storage and distribution of blood and resuscitative fluids, optical fabrication, medical equipment, and medical maintenance support. Medical logistic support within SOF varies greatly among the Services. Currently, the only organic medical logistic personnel in SOF are in the Army Special Forces Group medical sections and 528th SOSB, AFSOC special tactics groups and squadrons, and AFSOC special operations wings and groups. SOF do not have an organic medical maintenance capability. Theater medical planning guidance usually requires units to deploy with a 30-day basic load of medical supplies. For SOF units, the deployment basic load will vary from 2 days to 30 days. For some missions of specific duration, the SOF medical element may be required to deploy with medical supplies to sustain the entire mission. To determine medical logistical requirements, the medical planner must know the mission and its duration, the availability of supplies in theater, and the alternate medical supply systems outside of theater. Additionally, the medical planner must be thoroughly familiar with the overall concept of combat service support.

a. Medical Resupply. There are three methods of establishing a system for SOF medical supply.

(1) Conventional HSS System. During pre-mission planning, the medical planner must determine if there will be a conventional treatment facility with a medical logistics section near the support base. If so, he must coordinate with that unit to establish a medical supply account. Since the conventional medical logistics system may be too slow to meet SOF needs, a list of rapidly depleted items should be established during mission planning and requested immediately after the supply account is established.

(2) Pre-packaging. In an immature theater, the SOF planner must establish a pre-packaged medical resupply system supported from CONUS base or an in-theater location. Resupply packages are based on the type and duration of the mission and the projected time before the conventional system will become functional. Contingency supplies will be prepackaged, stored, and maintained as outlined in a memorandum of understanding between SOF and the providing medical logistics agency, with the approval of the theater command surgeon. The planner must also coordinate the movement of the supplies and the frequency of shipment with the SOF logistic elements. SOF transportation assets should be used whenever possible. The planner can convert to using the conventional system once it becomes functional. However, the pre-package system should be kept available for emergency or priority SOF needs for which the conventional system cannot respond.

(3) Contingency. When SOF are the only forces in the area of operations, the planner must establish an initial pre-packaged system and use the SOF nonmedical logistics system at the support base for medical resupply. For meeting emergency needs, the planner should establish a system for resupply directly from CONUS or through the in-country SAO. The latter should also be asked to provide a list of HN medical logistics sanctioned for use by US forces in emergencies.

b. Management of Blood and Associated Class VIII B Materiel. This category consists of blood products, volume expanders, and resuscitative fluids. It is addressed separately because of special transport, storage, and use requirements. SOF relies primarily on volume expanders, and will seldom deploy with whole blood. Whole blood may be required in specific cases.

To meet this need, the SOF medical planner must establish a written agreement with the theater surgeon/joint blood program officer or the local MTF commander before deployment specifying the number of units and blood type required and a predetermined timeframe to pick up the blood upon notifying the MTF. Additionally, the planner must plan for the transportation and cold storage of this perishable supply item. The planner must also arrange for resupply of less perishable but high turnover Class VIII B items like Ringer's Lactate. Once deployed, SOF must depend on previously arranged resupply from outside the theater and/or any prearranged HN options until the conventional HSS system is functional in-theater.

7. Laboratory Services. SF group medical personnel, the 528th SOSB, and AFSOC special operations medical elements provide the only medical laboratory services found in SOF. The SF medical sergeant is trained and equipped to provide basic clinical laboratory tests and procedures in support of UW and FID missions. Although some NAVSOF personnel are trained in this area, laboratory services are not doctrinal missions; therefore, these units lack laboratory equipment. Laboratory services beyond organic SOF medical capabilities must be coordinated through the theater command surgeon.

8. Dental Services. Organic dental capabilities in SOF are austere. A dental officer is assigned to each SF Group. Additionally, personnel receiving SF Medic (18D) training are trained to provide emergency dental care. Neither AFSOF nor NAVSOF have organic dental capabilities and must depend on the ARSOF or the conventional HSS system. Since dental problems can render SOF personnel nondeployable, SOF pre-deployment processing must include screening of dental records to determine treatment or examination requirements and confirm the presence of a panoramic dental x-ray.

9. Veterinary Services. Veterinary support is important to SOF, particularly in third world nations where humanitarian assistance and civic actions are primary objectives. Additionally, when SOF missions require local food purchase, arrangements must be made to have veterinary personnel inspect and approve food sources. Professional organic veterinary capability in SOF consists of a Veterinary Corps Officer assigned to each SF group and each Reserve PSYOP unit. Additionally, SOF medics are trained in basic veterinary medicine in the SF Medical Sergeant Course. This training is provided because of the FID and UW missions associated with SF. The Army is the sole provider of veterinary support for the Armed Forces.



10. Preventive Medicine. Keeping SOF personnel healthy and disease free is critical to mission accomplishment. Preventable diseases and environmental injuries have caused more casualties than combat in every war and conflict throughout military history. The austerity of SOF medical assets, absence of organic casualty evacuation and hospitalization capabilities, and importance of each individual's skills to the success of typically small SOF team missions all underscore the necessity for effective PM in SOF operations. Although PM is a command responsibility, the medical planner must anticipate (during operations planning) commanders' PM needs and then ensure that appropriate PM information and expert advice will be available during their preparations for and execution of the operation. The planner must initially coordinate with the theater command surgeon for guidance on projected PM requirements for specific operations being planned, since allocated SOF units will have to comply with that command's requirements when the plans are executed. The planner's next step is to characterize the PM threat in the region through current medical intelligence. The Armed Forces Medical Intelligence Center provides all-source medical intelligence (classified and unclassified) directly to requesters in a variety of formats and through several communications media. The Defense Pest Management Information Analysis Center provides detailed, location-specific information (unclassified) on all subjects relating to venomous animals and the prevention and control of insect-borne diseases (which comprise nearly two-thirds of the diseases of military importance worldwide). Analysis of the threat of food-borne, water-borne, and insect-borne diseases, venomous animals, and environmental hazards (e.g., heat and cold) should be accomplished by experienced PM personnel to identify the most appropriate countermeasures. When qualified PM personnel are not immediately available to the planning headquarters, the planner can seek assistance from the theater command surgeon, USSOCOM command surgeon, and the theater Service command surgeon. Planning considerations include immunization policy, chemoprophylaxis requirements, mandatory personal protective measures, and unit/team field sanitation and hygiene requirements. These must be disseminated to subordinate units in directive format (i.e., a PM appendix to medical services OPLAN annex or PM policy messages). This serves to emphasize PM as a responsibility of command, as well as to assist commanders by justifying priority acquisition of necessary PM equipment and materiel. When SOF are employed in a mature theater, the planner must identify conventional PM units and teams supporting the theater and methods of requesting their assistance. They can provide invaluable expert advice and assistance in solving specific PM problems, identifying actual and potential sources of disease, surveying for and controlling disease vector insects

on an area basis, and training and advising SOF medical personnel on all pertinent PM subjects.

11. Command, Control, and Communications. For most SO, SOF are provided by USCINCSOC (as supporting commander) to the supported theater combatant commander. In this case, the medical chain of support shifts to the theater command surgeon. There are three interrelated concerns for the SOF medical planner.

a. Contact with the Supported Theater. During premission planning, the planner must ascertain (through medical command channels) the requirements and policies of the theater command surgeon. Although SOF medical elements often operate separately from conventional forces, they have to know and comply with the theater medical policy.

b. Chain of Medical Supervision. A functional SOF chain of technical medical supervision is critical. Whereas ARSOF components (Ranger regiment and SF groups) will usually deploy with their respective surgeons, the NAVSOF and AFSOF components may deploy without a surgeon in the command structure. The absence of a surgeon and medical planner at any level may result in uncoordinated medical efforts and a break in the chain of communications to the theater command surgeon. SOF deploying without a surgeon or medical planner must notify the JFSOCC so that the JFSOCC surgeon can plan and coordinate HSS for that unit.

12. SOF Medical Capabilities

a. Level I. Casualties are evaluated and treated with emphasis primarily on those measures necessary to resuscitate, stabilize, and allow for the evacuation to the next level of care. With the exception of PSYOP and CA, all SOF units have this capability.

b. Level II. Casualties are evaluated, emergency care (to include beginning resuscitation) is continued, and any additional emergency measures are instituted not going beyond immediate necessities. With the exception of PSYOP and CA, all SOF components have this capability. However, they lack the conventional division-level 72-hour holding capability.

c. Level III. Casualties are evaluated and treated at an MTF staffed and equipped to provide treatment for all categories of casualties. Surgical intervention begins at this resuscitative level. SOF has one medical support element with Level III capability, and this element has limited post-operative holding and management

capability. A JFSOCC may receive medical augmentation with a Level II or III capability.

d. Level IV. Casualties are treated in a general hospital staffed and equipped for general and specialized medical and surgical care. Definitive surgery and recovery take place at this level. SOF do not need a dedicated Level IV capability.

13. HSS Planning Considerations. The six traditional pillars of HSS are wellness-fitness, prevention, far forward care, deployable hospitals, dedicated evacuation system, and CONUS support base. Significantly, SOF lack deployable hospitals and a dedicated evacuation system. Planners must evaluate the medical threat (heat, cold, altitude, water, food, disease, trauma, etc.) and arrange appropriate support. Planning HSS for SOF is a continuous process beginning with the actual planning for the operation, premission training, deployment, employment, and redeployment (see Figure O-1). SOF medical planners must stay attuned to operational requirements as they materialize and change throughout the operation. To provide comprehensive HSS and ensure mission success in a medically hostile environment, SOF medical planners must rely on flexibility, initiative, and innovation, as organic SOF medical capability is limited. Planners must consider all available medical resources, to include HN support, and make maximum use of all available assets. SOF medical planners must strive to follow the basic tenets of medical support--immediate stabilization as far forward as possible and expeditious evacuation. Coordination with medical planners from appropriate component Service and supporting command (e.g., USTRANSCOM) is essential in ensuring adequate HSS. Recognizing SOF's inherent HSS shortfalls, SOF medical planners should address the following:

a. Predeployment SOF Medic Training. SOF medics must be self-sufficient. SOF medics, corpsmen, and PJs receive enhanced medical training that exceeds the level and scope of conventional medic training. After baseline training, sustainment training is essential.

b. Preventive Medicine and Medical Intelligence. The medical threat must be defined in detail, and medical intelligence must be available to decrease the likelihood of disease and nonbattle injury.

c. Synchronization. Medical planners must ensure the integration of SOF medical activities with the activities of other supporting agencies. In particular, casualty

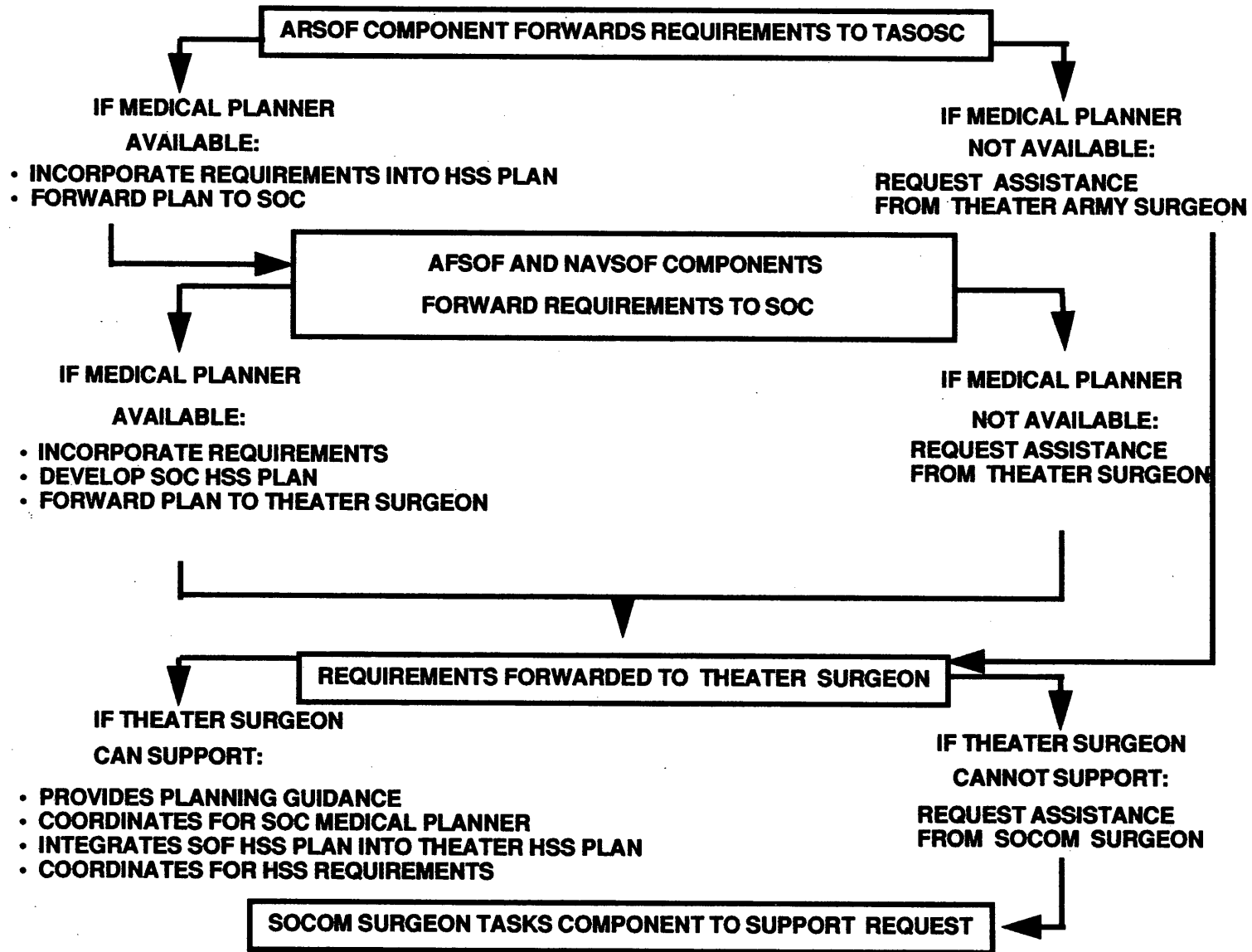

Figure O-1. SOF HSS Planning Aid

evacuation plans must be synchronized with the tactical and logistical air flows.

d. Close Coordination. HSS of SOF is a closely coordinated team effort. SOF medical personnel must be included in the operational planning process. Requirements and shortfalls identified by these planners must be forwarded to the theater medical planner or surgeon for resolution.

e. OPSEC. When the sensitivity of a particular mission requires compartmented planning, the SOF medical planner will submit requirements through classified operational channels to the appropriate medical command. Actual coordination is usually accomplished through LNOs designated by the JFSOCC.

f. Medical Regulating. Medical regulating is the system for coordinating and controlling the timely movement of casualties to the level of care best suited for providing the required treatment. In a mature theater, medical regulating offices (nodes) at various medical command levels ensure the flow of casualties to appropriate MTF inside or outside theater (including CONUS). The SOF medical planner must determine the point of entry into the HSS system for SOF casualties and how to subsequently track them. The conventional theater medical regulating system must be flexible and anticipate nonstandard, SOF medical regulating requirements.

14. Planning in a Developed Theater. Developed theaters have an established conventional HSS system. The JFSOCC must identify critical shortfalls to the theater combatant commander. The theater surgeon can provide medical personnel to help the JFSOCC plan, identify, and resolve medical shortfalls. If the theater surgeon cannot provide planning support, USCINCSOC may supply augmentation to support the planning process. The JFSOCC's medical planner coordinates support requirements through the SOJ3 and SOJ4 sections, who will forward requests to the theater surgeon's office for action.

15. Planning in an Undeveloped Theater. In undeveloped theaters, conventional HSS systems are minimal or absent. Medical planners must tailor support packages commensurate with the mission and attempt to provide all functional areas of HSS. From the onset of planning, SOF medical planners must coordinate with operational and logistic planners to ensure transportation and sustainment of medical assets, coordinate resources, and identify requirements. In undeveloped theaters, SOF medical planners must be opportunistic and take full advantage of operational and

logistical flows to expedite evacuation and medical resupply. To ensure mission success, medical planners should submit medical requirements as operational requirements.

16. Mission-Specific Medical Considerations. Medical considerations for each SOF mission are reviewed below:

a. Direct Action. Medical support of DA is generally directed toward immediate far forward treatment and stabilization and expeditious evacuation of casualties to a pre-designated MTF. Since most DA missions are conducted in denied areas, aerial medical evacuation is required to remove casualties from the field. Since dedicated medical evacuation aircraft may not be available, SOF medical planners must deliberately plan to utilize operational and logistical assets. Level III is required on an area support basis from the theater medical command.

b. Special Reconnaissance. Since SR missions are conducted deep in hostile or denied territory, medical support is austere. Aerial evacuation of SOF casualties would probably compromise the mission. SR teams must therefore rely on their own medical capabilities until the mission is accomplished and the team is extracted. Comprehensive medical intelligence is critical for SR missions. The medical threat requires evaluation of preventive medicine and countermeasures to protect SR elements from exposure to disease and injury.

c. Unconventional Warfare. The goals of medical operations in support of UW are to conserve the guerrilla force's fighting strength and to assist in securing local population support for US and resistance forces operating within JSOAs. Medical elements supporting the resistance forces must be mobile, responsive, and effective in preventing disease and restoring the sick and wounded to duty. There is no safe rear area where the guerrilla takes his casualties for treatment. Wounded and ill personnel become a tactical rather than a logistical problem. In a UW situation, indigenous medical personnel may provide assistance during combat operations by establishing casualty collection points, thus permitting the remaining members of the resistance force to continue to fight. Casualties at these collection points are later evacuated to the guerrilla base or guerrilla medical facility. As the area of operations develops, more seriously injured or diseased personnel are evacuated to friendly areas. Clandestine evacuation nets are established if security does not permit using aeromedical evacuation. Medical requirements within the JSOA differ from those posed by conventional forces.

Battle casualties are normally fewer and the incidence of disease and malnutrition is often higher.

d. Foreign Internal Defense. Medical services have proven to be one of the most effective ways to gain popular support for the HN government. Medical assistance is constructive in nature and is generally welcomed rather than feared. Medical assistance programs are requested by the HN government and may include providing medical treatment; education in basic sanitary procedures, hygiene, and preventive medicine; providing sanitary facilities, waste disposal, and controls; improving drinking water; and conducting immunization programs. These activities are aimed at:

- (1) Improving basic standards of living and health.
- (2) Involving the local population.
- (3) Enhancing the prestige of local authorities.

e. Counterterrorism. HSS planning for CT involves studying the mission and the area of operations to determine medical requirements. Equipment is kept to a minimum to support emergencies and routine illnesses. Special packing of the equipment is considered, especially for raid-type missions, to make essential items immediately accessible. Permission medical training concentrates on emergency medical treatment, advanced trauma management, and treatment of mass casualties.

17. Civil Affairs Support to Health Services. Within the CA community, public health officers and medical administrators can support health service activities by:

- a. Evaluating the HN medical and public health situation.
- b. Helping to improve or restore medical and public health infrastructure.
- c. Coordinating US military HSS with that of other US Government and nongovernment agencies.

This support is administrative in nature and does not include applied medical practice.

## APPENDIX P

## PERSONNEL FUNCTIONS

1. Purpose and Scope. This appendix provides information pertaining to JFSOCC personnel functions.

2. General. Personnel considerations are an integral part of the SO planning process. SOF units receive their manpower and personnel support through normal Service channels. SOF personnel planners must integrate Service personnel support into SO missions in a manner that complements operational plans. The SOJ1 must be knowledgeable of Service personnel policies and procedures to effect the required personnel support. Many times, personnel planning is constrained for specific SO missions by compartmented security requirements and compressed planning. These constraints reinforce the necessity for established SOP that are routinely practiced and validated during exercises.

3. Planning Considerations. SO missions will frequently require more personnel planning than most conventional missions. SO missions are often conducted outside established support areas and may require coordinating special Service procedures to provide personnel support. The four primary functions of the SOJ1 are strength reporting, casualty reporting, replacement operations, and personnel augmentation. Each is discussed in subsequent paragraphs. Additional SOJ1 functions include legal support; religious support; morale, welfare, and recreation; law, order, and discipline; personnel actions relating to operational readiness (emergency leaves, rotation policies, etc.); enemy prisoners of war; noncombatant evacuees; courier and postal services; and public affairs. Although some of these functions are Service responsibilities, SOJ1 coordination must occur to ensure Service systems meet SOF needs.

a. Personnel Strength Reporting. Personnel strength reporting should begin as early in the operation as possible. Subordinate units should report at least once every 24 hours. Internal suspenses should be established that allow sufficient preparation time to meet higher headquarters report times. The JFC will establish report times and format. Consideration should be given to the need for identifying special category personnel. These reporting requirements should be specified in reporting instructions to subordinate units. The JFSOCC must emphasize accurate and timely personnel reporting.

b. Personnel Casualty Reporting. Personnel casualty reporting is a Service responsibility. The SOJ1 must thoroughly understand each component Service casualty



reporting system, especially how component casualty data enters the system. Casualty information is considered sensitive and should be protected until official next of kin (NOK) notification is complete. NOK notification will be done by the respective Service. SOF component commanders should ensure that the SOC SOJ1 and USSOCOM SOJ1 are addressed for information on all subordinate unit casualty messages.

c. Replacement Operations. Replacement operations are a Service responsibility. The JFSOCC, in coordination with the Service component commanders and the JFC, must ensure Service replacement operations sustain SOF operational readiness. The low density of SO personnel and their lengthy train-up time may require a unit versus individual replacement plan. The SOJ1 must continually monitor strength reports and personnel requisitions to ensure that the replacement flow is responsive to unit needs and does not degrade operational readiness.

d. Personnel Augmentation. Theater SOCs should develop their augmentation requirements before operations begin, if possible. Wartime headquarters manning for SO missions will normally require substantial augmentation. For example, the theater SOC of US Central Command grew from 32 to 280 personnel during Operations DESERT SHIELD and DESERT STORM. This is a potential problem, as large numbers of new staff personnel unfamiliar with SO will hurt more than help, and detailing SOF personnel will degrade the capabilities of the losing unit.

(1) Sources for Augmentees. Augmentees may be Reserve component Individual Mobilization Augmentees who fill pre-designated positions, or they may be Active or Reserve component personnel who fill positions on an ad hoc basis. Individual mobilization augmentees train in their designated positions to be familiar with the duties that they will perform following mobilization. The JFSOCC may request or receive augmentation other than IMAs. They may come from SOF or other units within the theater or directly from the CONUS support base.

(2) Training. Staff augmentees must be trained. Clear, formal, SOPs are helpful. Training should include familiarization with SO-related joint and Service publications. On-the-job training is helpful if time and personnel are available. When the situation does not permit formal training, the JFSOCC must have reliable quality controls to ensure that mistakes are identified and corrected.

## APPENDIX Q

## DEPLOYMENT

1. Purpose and Scope. This appendix discusses deployment considerations unique to SOF. It may be used by the JFSOCC staff and SOF component commanders to anticipate problems not evident within the body of published joint doctrine.

2. General. SOF deployments are coordinated through established JOPES procedures. Joint Pub 5-03.1 is the primary reference for deployment planning and includes procedures for both deliberate planning and crisis action procedures. Although procedures for deploying SOF are the same as those for conventional forces, planners must be aware of the unique aspects in planning and executing SOF deployments and must understand the roles that each SOF command plays in the deployment process.

3. Force Modules. To improve responsiveness to theater combatant commanders and enhance SOF deployment readiness, USSOCOM and its Service components have developed a range of force deployment modules. Force deployment modules provide theater combatant commanders with flexible SOF deployment options consisting of over 50 complete SOF packages ranging in size from one SEAL platoon to an entire SF group. In addition to the combat force, modules consist of combat support units, organic sustainment and C3 elements. Force modules include both narrative information and TPFDD. Force module narratives provide the lift requirements, force capability descriptions, explanation of operational or logistical limitations, and logistical support required from the theaters. Using the force module data base (located in the JOPES automated system), theater combatant commanders can do rapid course of action analysis and transportation feasibility estimates. The TPFDD information can be transferred into the theater's deployment execution data base and used for controlling SOF deployment. Although force deployment modules are an excellent starting point for planning, SOF modules will require force tailoring to match a specific mission. Employment missions, basing facilities, expected duration of the contingency, etc., will drive changes to the size and composition of force modules.

4. Deployment of Special Mission Units. JOPES procedures are also used to deploy special mission units. To enhance OPSEC, JOPES "limited access" procedures may be used to safeguard sensitive deployment data. Limited access procedures provide a means to grant plan access to specific individuals within each command who have the requisite need-to-know. SPECAT deployment data may be coordinated using JOPES limited access procedures in conjunction with

normal special handling procedures. Special mission units may also require more precise delivery timetables than administrative deployments, particularly if they will be employed upon arrival in the objective area. If precise delivery profiles or specific delivery platforms are needed, coordination among deploying task force, gaining theater commands, USSOCOM and USTRANSCOM will be required in addition to standard JOPES coordination procedures.

5. Theater SOC Role in SOF Deployment. The theater combatant commander determines the role of COMSOC in SOF deployments. Normally, theater SOCs will plan the employment of SOF and make recommendations on the types of SO forces required to accomplish the mission. When forces are selected for employment, this is the first step in the deployment planning process. The deployment plan is then refined with selection of basing locations, phasing of forces into theater, and reception planning. Close coordination between the theater combatant command and USSOCOM (for CONUS SOF) is critical to ensure the deployment plan supports the concept of operations and forces can meet delivery phasing. The theater combatant commander may delegate the responsibility to coordinate SOF redeployments to the JFSOCC.

6. USSOCOM Role in SOF Deployments. As a supporting combatant commander, USCINCSOC is responsible for coordinating deployments of CONUS SOF based on type of forces and phasing required by theater combatant commander. USCINCSOC determines which specific units will be tasked to meet the theater's force requirement and provides specific unit deployment data to the theater using the JOPES. When the Secretary of Defense authorizes deployment, USCINCSOC will issue deployment orders to subordinate component commanders, validate to the theater combatant commander that forces are prepared to deploy, validate that cargo and personnel data in the TPFDD are accurate, and track deployments in progress to ensure forces are delivered on schedule. USSOCOM also maintains and refines the SOF force deployment module data base in JOPES.

7. USSOCOM Component Role in SOF Deployments. USSOCOM component commanders recommend specific units to meet theater force requirements and develop detailed deployment data in JOPES based on guidance from USCINCSOC and coordination with subordinate units. When deployment is authorized, component commanders provide specific deployment guidance to subordinate units, validate unit readiness to deploy and TPFDD accuracy to USSOCOM, and track deployments in progress. When airlift and sealift schedules are being developed, components may coordinate directly with USTRANSCOM on specific schedules and load configurations. Coordination with USTRANSCOM may not be used to revise deployment data

that USSOCOM has validated to theater commands. Components will also assist USSOCOM in maintaining respective portions of the force deployment module data base.

8. SOF Unit Role in Deployment. SOF units must be prepared to deploy as directed by USSOCOM components and the unit's higher headquarters. Unit commanders must develop detailed deployment data (equipment and personnel) and provide that data to their USSOCOM component commander. Changes to load data should not be made after the deployment data in JOPES have been validated by USSOCOM to the theater combatant commander. Validation normally occurs 7 days before actual deployment date for air movements (30 days before sea) to allow USTRANSCOM time to develop lift schedules. Any load changes within the "validation window" must be justified by USSOCOM and approved by the theater combatant command. Load changes will be considered only when there is a significant operational change requiring a new load plan.



APPENDIX R

USERS EVALUATION REPORT  
ON JOINT PUB 3-05.3

1. Users in the field are highly encouraged to directly submit comments on this pub. Please fill out and send in the following: Users' POC, unit address, and phone (DSN) number.

---

---

2. Content

a. Does the pub provide a conceptual framework for the topic? \_\_\_\_\_

---

b. Is the information provided accurate? What needs to be updated? \_\_\_\_\_

---

c. Is the information provided useful? If not, how can it be improved? \_\_\_\_\_

---

d. Is this pub consistent with other joint pubs? \_\_\_\_\_

---

e. Can this pub be better organized for the best understanding of the doctrine and/or JTTP? How? \_\_\_\_\_

---

3. Writing and Appearance

a. Where does the pub need some revision to make the writing clear and concise? What words would you use? \_\_\_\_\_

---

b. Are the charts and figures clear and understandable? How would you revise them? \_\_\_\_\_

---

4. Recommended urgent change(s) (if any). \_\_\_\_\_

---

5. Other \_\_\_\_\_

---

6. Please fold and mail comments to the Joint Doctrine Center (additional pages may be attached if desired) or FAX to DSN 564-3990 or COMM (804) 444-3990.

(FOLD)

---

FROM:

JOINT DOCTRINE CENTER  
BLDG R-52  
1283 CV TOWWAY STE 100  
NORFOLK, VA 23511-2491

---

(FOLD)

## GLOSSARY

## PART I-ABBREVIATIONS AND ACRONYMS

AADC	area air defense commander
AAFES	Army and Air Force Exchange Service
AAWC	antiair warfare commander (Navy)
ABCCC	airborne battlefield command and control center
ACA	airspace control authority
A/DACG	arrival/departure airfield control group
ADCON	administrative control
ADP	automatic data processing
AFFOR	Air Force forces
AFSOB	Air Force special operations base
AFSOC	Air Force special operations component
AFSOD	Air Force special operations detachment
AFSOE	Air Force special operations element
AFSOF	Air Force special operations forces
AIASA	Annual Integrated Assessment of Security Assistance
ALOC	air lines of communications
AMPN	amplification
AO	area of operations
AOB	advanced operations base
AOC	air operations center (Air Force)
AOR	area of responsibility
APOD	aerial port of debarkation
APOE	aerial port of embarkation
ARFOR	Army forces
ARSOA	Army special operations aviation
ARSOC	Army special operations component
ARSOF	Army special operations forces
ARSOTF	Army special operations task force
ASUWC	antisurface warfare commander (Navy)
ASWC	antisubmarine warfare commander (Navy)
ATO	air tasking order
AUTODIN	automatic data information network
AWACS	airborne warning and control system
BLS	beach landing site
C2	command and control
C3	command, control, and communications
C4	command, control, communications, and computers
C4I	command, control, communications, computers, and intelligence
CA	civil affairs
C-E	communications-electronics
CHOP	change of operational control
CI	counterintelligence



CIA	Central Intelligence Agency
CINC	commander in chief (of a combatant command)
CJCS	Chairman of the Joint Chiefs of Staff
CLIPS	Communications Link Interface Planning System
CMTS	comments
COCOM	Combatant Command (command authority)
COMAFFOR	commander, Army forces
COMAFSOC	commander, Air Force special operations component
COMSEC	communications security
COMSOC	commander, special operations command
COMSOCCENT	Commander, Special Operations Command, Central
CONPLAN	operation plan in concept format
CONUS	continental United States
CP	command post
CRRC	combat rubber raiding craft
CSAR	combat search and rescue
CT	counterterrorism
CWC	composite warfare commander (Navy)
DA	direct action
DAO	defense attache office
DCS	Defense Communications System
DDS	dry deck shelter
DFT	deployment for training
DIA	Defense Intelligence Agency
DIRLAUTH	direct liaison authorized
DMA	Defense Mapping Agency
DOD	Department of Defense
DODAAC	DOD activity address code
DODAAF	DOD activity address file
DOS	Department of State
DSAA	Defense Security Assistance Agency
DTG	date-time group
DZ	drop zone
EALT	earliest anticipated launch time
E&E	evasion and escape
E EI	essential elements of information
EMCON	emission control
FAD	force activity designator
FARP	forward arming and refueling point
FBI	Federal Bureau of Investigation
FID	foreign internal defense
FLIR	forward-looking infrared
FM	frequency modulation
FNS	foreign nation support
FOB	forward operations base
FSB	forward staging base

GENSER	general service
GMT	Greenwich mean time
GW	guerrilla warfare
HAHO	high-altitude high-opening parachute technique
HALO	high-altitude low-opening parachute technique
HF	high frequency
HN	host nation
HNS	host nation support
HPMSK	high priority mission support kit
HSS	health service support
HUMINT	human resources intelligence
HQ	headquarters
IDCA	International Development Cooperation Agency
IFF	identification, friend or foe
IG	inspector general
IMA	individual mobilization augmentee
IOM	installation, operation, and maintenance
IPA	intelligence production agency
IR	infrared
ISB	intermediate staging base
ISSA	inter-Service support agreement
JCEOI	joint communications-electronics operations instructions
JCSE	Joint Communications Support Element
JFACC	Joint Force Air Component Commander
JFC	Joint Force Commander
JFMCC	Joint Force Maritime Component Commander
JFSOCC	Joint Force Special Operations Component Commander
JIC	joint intelligence center
JIOP	joint interface operational procedures
JMETL	joint mission-essential task list
JOC	joint operations center
JOPES	Joint Operation Planning and Execution System
JPO	joint petroleum office
JRCC	joint rescue coordination center
JSCP	Joint Strategic Capabilities Plan
JSOA	joint special operations area
JSOAC	Joint Special Operations Air Component
JSOACC	Joint Special Operations Air Component Commander
JSOTF	joint special operations task force
JSPS	Joint Strategic Planning System
JTCB	joint targeting coordination board
JTF	joint task force
JTIC	joint transportation intelligence center
JTTP	joint tactics, techniques, and procedures
JULLS	Joint Universal Lessons Learned System

KW	kilowatt
LAN	local area network
LNO	liaison officer
LRC	logistics readiness center
LZ	landing zone
MAGTF	Marine air-ground task force
MARFOR	Marine Corps forces
MASF	mobile aeromedical staging facility
MCA	mission concept approval
METL	mission-essential task list
MEU(SOC)	Marine expeditionary unit (special operations capable)
MFP	major force program
MHE	materials handling equipment
MICON	mission concept
MITASK	mission tasking
MOB	main operations base
MOS	military occupational specialty
MPA	mission planning agent
MRE	meal, ready-to-eat
MSC	mission support confirmation
MSL	mean sea level
MSPF	maritime special purpose force
MSR	mission support request
MTF	medical treatment facility
MTT	mobile training team
NAVFOR	Navy forces
NAVSOC	naval special operations component
NAVSOF	Navy special operations forces
NAVSPECWARCOM	Naval Special Warfare Command
NBC	nuclear, biological, and chemical
NCA	National Command Authorities
NCO	noncommissioned officer
NEO	noncombatant evacuation operations
NFA	no-fire area
NIST	national intelligence support team
NLT	not later than
NMET	Naval Mobile Environmental Teams
NOK	next of kin
NRT	near-real-time
NSA	National Security Agency
NSW	Naval Special Warfare
NSWG	Naval Special Warfare Group
NSWTG	Naval Special Warfare Task Group
NSWTU	Naval Special Warfare Task Unit
NSWU	Naval Special Warfare Unit
NVG	night vision goggles

OB	order of battle
OCONUS	outside the continental United States
ODA	operational detachment-Alpha
ODB	operational detachment-Bravo
OIR	other intelligence requirements
OPCON	operational control
OPLAN	operation plan
OPLAW	operational law
OPORD	operation order
OPSEC	operations security
OPSUM	operation summary
OSS	Office of Strategic Services
PAO	public affairs office(r)
PIR	priority intelligence requirements
PJ	individual pararescue specialist
PLS	personnel locator system
PLT	platoon
PM	preventive medicine
POAS	PSYOP Automation System
POD	port of debarkation
POE	port of embarkation
POL	petroleum, oils, and lubricants
POLAD	political advisor
POW	prisoner of war
PRC	population and resources control
PRT	pararescue team
PSYOP	psychological operations
PWRS	pre-positioned war reserve stock
PZ	pickup zone
RAST	recovery, assist, secure, and traverse
RC	Reserve component
RCC	rescue coordination center
REQCONF	request confirmation
RFA	restricted fire area
RFI	request for information
RGR	ranger
ROE	rules of engagement
RZ	recovery zone
SAO	security assistance office
SAP	special access program
SAR	search and rescue
SATCOM	satellite communications
SBR	special boat squadron
SBU	special boat unit
SCI	sensitive compartmented information
SCIF	sensitive compartmented information facility
SDV	SEAL delivery vehicle

SEAL	sea-air-land (team)
SERE	survival, evasion, resistance, and escape
SF	Special Forces
SFOB	Special Forces operations base
SFOD-A/B/C	Special Forces operational detachment-A/B/C
SHF	super high frequency
SI	special intelligence
SID	secondary imagery dissemination
SIGINT	signals intelligence
SITREP	situation report
SJA	staff judge advocate
SMU	special mission unit
SO	special operations
SOA	special operations aviation
SOC	special operations command
SOCA	special operations communications assembly
SOCCE	special operations command and control element
SOCCT	special operations combat control team
SOCP	special operations communication package
SOCRATES	Special Operations Command, Research, Analysis and Threat Evaluation System
SODARS	Special Operations Debrief and Retrieval System
SOF	special operations forces
SOG	special operations group
SOI	signal operating instructions
SOLE	special operations liaison element
SOLL	special operations low-level
SOMPF	special operations mission planning folder
SOP	standard operating procedure
SOS	special operations squadron
SOSB	special operations support battalion
SOSC	special operations support command (theater army)
SOW	special operations wing
SOWT/TE	special operations weather team/tactical element
SPECAT	special category
SR	special reconnaissance
SSO	special security office
STAR	surface-to-air recovery (Fulton)
STICS	scalable transportable intelligence communications system
STS	special tactics squadron
STT	special tactics team
STU	secure telephone unit
STWC	strike warfare commander (Navy)
TACC	tactical air command center (Marine)
TACON	tactical control
TACSAT	tactical satellite (communications)

TASOSC	Theater Army Special Operations Support Command
TIP	target intelligence package
TNAPS	Tactical Network Analysis and Planning System
TOC	tactical operations center
TOT	time on target
TPFDD	time-phased force and deployment data
TTP	tactics, techniques, and procedures
UHF	ultra-high frequency
UNAAF	unified action armed forces
USAF	United States Air Force
USAID	United States Agency for International Development
USASOC	United States Army Special Operations Command
USIA	United States Information Agency
USC	United States Code
USCINCCENT	Commander in Chief, US Central Command
USCINCSOC	Commander in Chief, US Special Operations Command
USMTF	United States message text format
USSOCOM	United States Special Operations Command
USTRANSCOM	United States Transportation Command
UTM	universal transverse mercator
UW	unconventional warfare
VHF	very high frequency
VIP	very important person
WRM	war reserve materiel
WRSK	war reserve spares kit
WWMCCS	Worldwide Military Command and Control System

## PART II-TERMS AND DEFINITIONS

administrative control. Direction or exercise of authority over subordinate or other organizations in respect to administrative matters such as personnel management, supply, services, and other matters not included in the operational missions of the subordinate or other organizations. (Joint Pub 1-02)

advanced operations base. In special operations, a small temporary base established near or within a joint special operations area to command, control, and/or support training or tactical operations. Facilities are normally austere. The base may be ashore or afloat. If ashore, it may include an airfield or unimproved airstrip, a pier, or an anchorage. An advanced operations base is normally controlled and/or supported by a main operations base or a forward operations base. Also called AOB. (Approved for inclusion in the next edition of Joint Pub 1-02)

Air Force special operations base. That base, airstrip, or other appropriate facility that provides physical support to Air Force special operations forces. The facility may be used solely to support Air Force special operations forces or may be a portion of a larger base supporting other operations. As a supporting facility, it is distinct from the forces operating from or being supported by it. Also called AFSOB. (Joint Pub 1-02)

Air Force special operations component. The Air Force component of a joint force special operations component. Also called AFSOC. (Joint Pub 1-02)

Air Force special operations detachment. A squadron-size headquarters, which could be a composite organization composed of different Air Force special operations assets. The detachment is normally subordinate to an Air Force special operations component, joint special operations task force, or joint task force, depending upon size and duration of the operation. Also called AFSOD. (Joint Pub 1-02)

Air Force special operations element. An element-size Air Force special operations headquarters. It is normally subordinate to an Air Force special operations component or detachment, depending upon size and duration of the operation. Also called AFSOE. (Approved for inclusion in the next edition of Joint Pub 1-02)

Air Force special operations forces. Those active and reserve component Air Force forces designated by the Secretary of Defense that are specifically organized, trained, and equipped to conduct and support special operations. Also called AFSOF. (Joint Pub 1-02)

alert order. 1. A crisis-action planning directive from the Secretary of Defense, issued by the Chairman of the Joint Chiefs of Staff, that provides essential guidance for planning and directs the initiation of execution planning for the selected course of action authorized by the Secretary of Defense. 2. A planning directive that provides essential planning guidance and directs the initiation of execution planning after the directing authority approves a military course of action. An alert order does not authorize execution of the approved course of action. (This term and its definition are provided for information and are proposed for inclusion in the next edition of Joint Pub 1-02 by Joint Pub 5-0.)

antiterrorism. Defensive measures used to reduce the vulnerability of individuals and property to terrorism. See also counterterrorism and terrorism. (Joint Pub 1-02)

architecture. A framework or structure that portrays relationships among all the elements of the subject force, system, or activity. (Joint Pub 1-02)

area assessment. The commander's prescribed collection of specific information that commences upon employment and is a continuous operation. It confirms, corrects, refutes, or adds to previous intelligence acquired from area studies and other sources prior to employment. (Joint Pub 1-02)

area oriented. Personnel or units whose organizations, mission, training, and equipping are based on projected operational deployment to a specific geographic or demographic area. (Joint Pub 1-02)

Army special operations component. The Army component of a joint force special operations component. Also called ARSOC. (Approved for inclusion in the next edition of Joint Pub 1-02)

Army special operations forces. Those active and reserve component Army forces designated by the Secretary of Defense that are specifically organized, trained, and equipped to conduct and support special operations. Also called ARSOF. (Joint Pub 1-02)



automatic resupply. A resupply mission fully planned before insertion of a special operations team into the operations area that occurs at a prearranged time and location, unless changed by the operating team after insertion. (Approved for inclusion in the next edition of Joint Pub 1-02)

bare base. A base having minimum essential facilities to house, sustain, and support operations to include, if required, a stabilized runway, taxiways, and aircraft parking areas. A bare base must have a source of water that can be made potable. Other requirements to operate under bare base conditions form a necessary part of the force package deployed to the bare base. (Approved for inclusion in the next edition of Joint Pub 1-02)

beach landing site. A geographic location selected for across-the-beach infiltration, exfiltration, or resupply operations. Also called BLS. (Joint Pub 1-02)

blind transmission. Any transmission of information that is made without expectation of acknowledgment. (Joint Pub 1-02)

campaign plan. A plan for a series of related military operations aimed to accomplish a common objective, normally within a given time and space. (Joint Pub 1-02)

capability. The ability to execute a specified course of action. (A capability may or may not be accompanied by an intention.) (Joint Pub 1-02).

cell. Small group of individuals who work together for clandestine or subversive purposes. (Joint Pub 1-02)

civil affairs. The activities of a commander that establish, maintain, influence, or exploit relations between military forces and civil authorities, both governmental and nongovernmental, and the civilian populace in a friendly, neutral, or hostile area of operations in order to facilitate military operations and consolidate operational objectives. Civil affairs may include performance by military forces of activities and functions normally the responsibility of local government. These activities may occur prior to, during, or subsequent to other military actions. They may also occur, if directed, in the absence of other military operations. (Joint Pub 1-02)

clandestine operation. An operation sponsored or conducted by governmental departments or agencies in such a way as to assure secrecy or concealment. A clandestine operation differs from a covert operation in that emphasis is placed on

concealment of the operation rather than on concealment of identity of sponsor. In special operations, an activity may be both covert and clandestine and may focus equally on operational considerations and intelligence-related activities. (Approved for inclusion in the next edition of Joint Pub 1-02)

coalition force. A force composed of military elements of nations that have formed a temporary alliance for some specific purpose. (Joint Pub 1-02)

collateral mission. A mission other than those for which a force is primarily organized, trained, and equipped, that the force can accomplish by virtue of the inherent capabilities of that force. (Approved for inclusion in the next edition of Joint Pub 1-02)

Combatant Command (command authority). Non-transferable command authority established by title 10, United States Code, section 164, exercised only by commanders of unified or specified combatant commands. Combatant Command (command authority) is the authority of a Combatant Commander to perform those functions of command over assigned forces involving organizing and employing commands and forces, assigning tasks, designating objectives, and giving authoritative direction over all aspects of military operations, joint training, and logistics necessary to accomplish the missions assigned to the command. Combatant Command (command authority) should be exercised through the commanders of subordinate organizations; normally this authority is exercised through the Service component commander. Combatant Command (command authority) provides full authority to organize and employ commands and forces as the CINC considers necessary to accomplish assigned missions. Also called COCOM. (Joint Pub 1-02)

combat control team. A team of Air Force personnel organized, trained, and equipped to establish and operate navigational or terminal guidance aids, communications, and aircraft control facilities within the objective area of an airborne operation. (Joint Pub 1-02)

combat search and rescue. A specific task performed by rescue forces to effect the recovery of distressed personnel during wartime or contingency operations. Also called CSAR. (Joint Pub 1-02)

combatting terrorism. Actions, including antiterrorism (defensive measures taken to reduce vulnerability to terrorist acts) and counterterrorism (offensive measures taken to prevent, deter, and respond to terrorism) taken to oppose terrorism throughout the entire threat spectrum. (Joint Pub 1-02)

command and control. The exercise of authority and direction by a properly designated commander over assigned forces in the accomplishment of the mission. Command and control functions are performed through an arrangement of personnel, equipment, communications, facilities, and procedures employed by a commander in planning, directing, coordinating, and controlling forces and operations in the accomplishment of the mission. (Joint Pub 1-02)

command control, communications, and computer systems. Integrated systems of doctrine, procedures, organizational structures, personnel, equipment, facilities, and communications designed to support a commander's exercise of command and control, through all phases of the operational continuum. Also called C4 systems. (Joint Pub 1-02)

common servicing. That function performed by one Military Service in support of another Military Service for which reimbursement is not required from the Service receiving support. See also servicing. (Joint Pub 1-02)

compartmentation. 1. Establishment and management of an organization so that information about the personnel, internal organization, or activities of one component is made available to any other component only to the extent required for the performance of assigned duties. 2. Effects of relief and drainage upon avenues of approach so as to produce areas bounded on at least two sides by terrain features such as woods, ridges, or ravines that limit observation or observed fire into the area from points outside the area. (Approved for inclusion in the next edition of Joint Pub 1-02)

compromise. The known or suspected exposure of clandestine personnel, installations, or other assets or of classified information or material, to an unauthorized person. (Joint Pub 1-02)

conventional forces. Those forces capable of conducting operations using nonnuclear weapons. (Joint Pub 1-02)

counterdrug. Those active measures taken to detect, monitor, and counter the production, trafficking, and use of illegal drugs. Also called CD. (Joint Pub 1-02)

counterinsurgency. Those military, paramilitary, political, economic, psychological, and civic actions taken by a government to defeat insurgency. (Joint Pub 1-02)

counterterrorism. Offensive measures taken to prevent, deter, and respond to terrorism. Also called CT. (Joint Pub 1-02)

cover (military). Actions to conceal actual friendly intentions, capabilities, operations, and other activities by providing a plausible, yet erroneous, explanation of the observable. (Joint Pub 1-02)

covert operation. An operation that is so planned and executed as to conceal the identity of or permit plausible denial by the sponsor. A covert operation differs from a clandestine operation in that emphasis is placed on concealment of identity of sponsor rather than on concealment of the operation. (Approved for inclusion in the next edition of Joint Pub 1-02)

cross-servicing. That function performed by one Military Service in support of another Military Service for which reimbursement is required from the Service receiving support. (Joint Pub 1-02)

deception. Those measures designed to mislead the enemy by manipulation, distortion, or falsification of evidence to induce him to react in a manner prejudicial to his interests. (Joint Pub 1-02)

deliberate planning. 1. The JOPES process involving the development of joint operations plans for contingencies identified in joint strategic planning documents. Conducted principally in peacetime, deliberate planning is accomplished in prescribed cycles that complement other DOD planning cycles and in accordance with the formally established Joint Strategic Planning System. 2. A planning process for the deployment and employment of apportioned forces and resources that occurs in response to a hypothetical situation. Deliberate planners rely heavily on assumptions regarding the circumstances that will exist when the plan is executed. (This term and its definition are provided for information and are proposed for inclusion in the next edition of Joint Pub 1-02 by Joint Pub 5-0.)

denial measure. An action to hinder or deny the enemy the use of space, personnel, or facilities. It may include destruction, removal, contamination, or erection of obstructions. (Joint Pub 1-02)

deployment order. A crisis-action planning directive from the Secretary of Defense, issued by the Chairman of the Joint Chiefs of Staff, that authorizes and directs the transfer of forces between combatant commands by reassignment or attachment. A deployment order normally specifies the authority that the gaining combatant commander will exercise over the transferred forces. (This definition is provided for information and is proposed for inclusion in the next edition of Joint Pub 1-02 by Joint Pub 5-0.)

direct action. Short-duration strikes and other small-scale offensive actions by special operations forces to seize, destroy, capture, recover, or inflict damage on designated personnel or materiel. In the conduct of these operations, special operations forces may employ raid, ambush, or direct assault tactics; emplace mines and other munitions; conduct standoff attacks by fire from air, ground, or maritime platforms; provide terminal guidance for precision-guided munitions; and conduct independent sabotage. Also called DA. (Joint Pub 1-02)

dry deck shelter. A shelter module that attaches to the hull of a specially configured submarine to provide the submarine with the capability to launch and recover special operations personnel, vehicles, and equipment while submerged. The dry deck shelter provides a working environment at one atmosphere for the special operations element during transit and has structural integrity to the collapse depth of the host submarine. Also called DDS. (Approved for inclusion in the next edition of Joint Pub 1-02)

earliest anticipated launch time. The earliest time expected for a special operations tactical element and its supporting platform to depart the staging or marshalling area together en route to the operations area. Also called EALT. (Joint Pub 1-02)

emergency resupply. A resupply mission that occurs based on a predetermined set of circumstances and time interval should radio contact not be established or, once established, is lost between a special operations tactical element and its base. See also automatic resupply. (Approved for inclusion in the next edition Joint Pub 1-02)

evasion and escape. The procedures and operations whereby military personnel and other selected individuals are enabled to emerge from an enemy-held or hostile area to areas under friendly control. (Joint Pub 1-02)

evasion and escape net. The organization within enemy-held or hostile areas that operates to receive, move, and exfiltrate military personnel or selected individuals to friendly control. (Joint Pub 1-02)

execute order. 1. An order issued by the Chairman of the Joint Chiefs of Staff, by authority and at the direction of the Secretary of Defense, to implement an NCA decision to initiate military operations. 2. An order to initiate military operations as directed. (This term and its definition are provided for information and are proposed for inclusion in the next edition of Joint Pub 1-02 by Joint Pub 5-0.)

exfiltration. The removal of personnel or units from areas under enemy control. (Joint Pub 1-02)

force multiplier. A capability that, when added to and employed by a combat force, significantly increases the combat potential of that force and thus enhances the probability of successful mission accomplishment. (Approved for inclusion in the next edition of Joint Pub 1-02)

foreign internal defense. Participation by civilian and military agencies of a government in any of the action programs taken by another government to free and protect its society from subversion, lawlessness, and insurgency. (Joint Pub 1-02)

forward arming and refueling point. A temporary facility, organized, equipped, and deployed by an aviation commander, and normally located in the main battle area closer to the area of operation than the aviation unit's combat service area, to provide fuel and ammunition necessary for the employment of aviation maneuver units in combat. The forward arming and refueling point permits combat aircraft to rapidly refuel and rearm simultaneously. Also called FARP. (Joint Pub 1-02)

forward operations base. In special operations, a base usually located in friendly territory or afloat that is established to extend command and control or communications or to provide support for training and tactical operations. Facilities may be established for temporary or longer duration operations and may include an airfield or an unimproved airstrip, an anchorage, or a pier. A forward operations base may be the location of special operations component headquarters or a smaller unit that is controlled and/or supported by a main operations base. Also called FOB. (Approved for inclusion in the next edition of Joint Pub 1-02)

functional component command. A command normally, but not necessarily, composed of forces of two or more Services which may be established in peacetime or war to perform particular operational missions that may be of short duration or may extend over a period of time. (Joint Pub 1-02)

guerrilla force. A group of irregular, predominantly indigenous personnel organized along military lines to conduct military and paramilitary operations in enemy-held, hostile, or denied territory. (Joint Pub 1-02)

guerrilla warfare. Military and paramilitary operations conducted in enemy held or hostile territory by irregular, predominantly indigenous forces. (Joint Pub 1-02)

humanitarian assistance. Programs conducted to relieve or reduce the results of natural or manmade disasters or other endemic conditions such as human pain, disease, hunger, or privation that might present a serious threat to life or that can result in great damage to or loss of property. Humanitarian assistance provided by US forces is limited in scope and duration. The assistance provided is designed to supplement or complement the efforts of the host nation civil authorities or agencies that may have the primary responsibility for providing humanitarian assistance. (Joint Pub 1-02)

humanitarian and civic assistance. Assistance to the local populace provided by predominantly US forces in conjunction with military operations and exercises. This assistance is specifically authorized by title 10, United States Code, section 401, and funded under separate authorities. Assistance provided under these provisions is limited to (1) medical, dental, and veterinary care provided in rural areas of a country; (2) construction of rudimentary surface transportation systems; (3) well drilling and construction of basic sanitation facilities; and (4) rudimentary construction and repair of public facilities. Assistance must fulfill unit training requirements that incidentally create humanitarian benefit to the local populace. (Approved for inclusion in the next edition of Joint Pub 1-02)

in extremis. A situation of such exceptional urgency that immediate action must be taken to minimize imminent loss of life or catastrophic degradation of the political or military situation. (Joint Pub 1-02)

infiltration. 1. The movement through or into an area or territory occupied by either friendly or enemy troops or organizations. The movement is made, either by small groups or by individuals, at extended or irregular intervals. When used in connection with the enemy, it infers that contact is avoided. 2. In intelligence usage, placing an agent or other person in a target area in hostile territory. Usually involves crossing a frontier or other guarded line. Methods of infiltration are: black (clandestine); grey (through legal crossing point but under false documentation); white (legal). (Joint Pub 1-02)

insurgency. An organized movement aimed at the overthrow of a constituted government through use of subversion and armed conflict. (Joint Pub 1-02)

intelligence production agency.\* In special operations usage, the agency of the Intelligence Community that produces target intelligence data in support of special operations mission planning.

interoperability. 1. The ability of systems, units, or forces to provide services to and accept services from other systems, units, or forces and to use the services so exchanged to enable them to operate effectively together. 2. The condition achieved among communications-electronics systems or items of communications-electronics equipment when information or services can be exchanged directly and satisfactorily between them and/or their users. The degree of interoperability should be defined when referring to specific cases. (Joint Pub 1-02)

inter-Service support. Action by one Military Service or element thereof to provide logistic and/or administrative support to another Military Service or element thereof. Such action can be recurring or nonrecurring in character on an installation, area, or worldwide basis. (Joint Pub 1-02)

irregular forces. Armed individuals or groups who are not members of the regular armed forces, police, or other internal security forces. (Joint Pub 1-02)

joint force air component commander. The joint force air component commander derives his authority from the joint force commander who has the authority to exercise operational control, assign missions, direct coordination among his subordinate commanders, redirect and organize his forces to ensure unity of effort in the accomplishment of his overall mission. The joint force commander will normally designate a joint force air component commander. The joint force air



component commander's responsibilities will be assigned by the joint force commander (normally these would include, but not be limited to, planning, coordination, allocation, and tasking based on the joint force commander's apportionment decision). Using the joint force commander's guidance and authority, and in coordination with other Service component commanders and other assigned or supporting commanders, the joint force air component commander will recommend to the joint force commander apportionment of air sorties to various missions or geographic areas. Also called JFACC. (Joint Pub 1-02)

joint force commander. A general term applied to a commander authorized to exercise Combatant Command (command authority) or operational control over a joint force. Also called JFC. (Joint Pub 1-02)

joint force land component commander. The commander within a unified command, subordinate unified command, or joint task force responsible to the establishing commander for making recommendations on the proper employment of land forces, planning and coordinating land operations, or accomplishing such operational missions as may be assigned. The joint force land component commander is given the authority necessary to accomplish missions and tasks assigned by the establishing commander. The joint force land component commander will normally be the commander with the preponderance of land forces and the requisite command and control capabilities. Also called JFLCC. (Joint Pub 1-02)

joint force maritime component commander. The commander within a unified command, subordinate unified command, or joint task force responsible to the establishing commander for making recommendations on the proper employment of maritime forces and assets, planning and coordinating maritime operations, or accomplishing such operational missions as may be assigned. The joint force maritime component commander is given the authority necessary to accomplish missions and tasks assigned by the establishing commander. The joint force maritime component commander will normally be the commander with the preponderance of maritime forces and the requisite command and control capabilities. Also called JFMCC. (Joint Pub 1-02)

joint force special operations component commander. The commander within a unified command, subordinate unified command, or joint task force responsible to the establishing commander for making recommendations on the proper employment of special operations forces and assets, planning and coordinating special operations, or accomplishing such

operational missions as may be assigned. The joint force special operations component commander is given the authority necessary to accomplish missions and tasks assigned by the establishing commander. The joint force special operations component commander will normally be the commander with the preponderance of special operations forces and the requisite command and control capabilities. Also called JFSOCC. (Joint Pub 1-02)

joint servicing. That function performed by a jointly staffed and financed activity in support of two or more Military Services. (Joint Pub 1-02)

joint special operations air component commander. The commander within the joint force special operations command responsible for planning and executing joint special air operations and for coordinating and deconflicting such operations with conventional nonspecial operations air activities. The joint special operations air component commander normally will be the commander with the preponderance of assets and/or greatest ability to plan, coordinate, allocate, task, control, and support the assigned joint special operations aviation assets. The joint special operations air component commander may be directly subordinate to the joint force special operations component commander or to any nonspecial operations component or joint force commander as directed. Also called JSOACC. (Approved for inclusion in the next edition of Joint Pub 1-02)

joint special operations area. A restricted area of land, sea, and airspace assigned by a joint force commander to the commander of a joint special operations force to conduct special operations activities. The commander of joint special operations forces may further assign a specific area or sector within the joint special operations area to a subordinate commander for mission execution. The scope and duration of the special operations forces' mission, friendly and hostile situation, and politico-military considerations all influence the number, composition, and sequencing of special operations forces deployed into a joint special operations area. It may be limited in size to accommodate a discrete direct action mission or may be extensive enough to allow a continuing broad range of unconventional warfare operations. Also called JSOA. (Approved for inclusion in the next edition of Joint Pub 1-02)

joint special operations task force. A joint task force composed of special operations units from more than one Service, formed to carry out a specific special operation or prosecute special operations in support of a theater campaign

or other operations. The joint special operations task force may have conventional nonspecial operations units assigned or attached to support the conduct of specific missions. Also called JSOTF. (Joint Pub 1-02)

low visibility operations. Sensitive operations wherein the political-military restrictions inherent in covert and clandestine operations are either not necessary or not feasible; actions are taken as required to limit exposure of those involved and/or their activities. Execution of these operations is undertaken with the knowledge that the action and/or sponsorship of the operation may preclude plausible denial by the initiating power. (Joint Pub 1-02)

main operations base. In special operations, a base established by a joint force special operations component commander or a subordinate special operations component commander in friendly territory to provide sustained command and control, administration, and logistic support to special operations activities in designated areas. Also called MOB. (Approved for inclusion in the next edition of Joint Pub 1-02)

mission planning agent.\* The subordinate special operations force commander designated by the joint force special operations component commander to validate, plan, and execute a particular special operations mission. Also called MPA.

mission tasking.\* A directive that assigns a mission to a subordinate commander, provides essential planning guidance, and directs the initiation of mission planning. A mission tasking may be issued as a warning order, planning order, alert order, or execute order. Also called MITASK.

National Command Authorities. The President and the Secretary of Defense or their duly deputized alternates or successors. Commonly referred to as NCA. (Joint Pub 1-02)

naval mobile environmental team. A team of naval personnel organized, trained, and equipped to support maritime special operations by providing weather, oceanography, mapping, charting, and geodesy support. Also called NMET. (Joint Pub 1-02)

naval special warfare. A specific term describing a designated naval warfare specialty and covering operations generally accepted as being unconventional in nature and, in many cases, covert or clandestine in character. These operations include using specially trained forces assigned to conduct unconventional warfare, psychological operations, beach and coastal reconnaissance, operational deception

operations, counterinsurgency operations, coastal and river interdiction, and certain special tactical intelligence collection operations that are in addition to those intelligence functions normally required for planning and conducting special operations in a hostile environment. Also called NSW. (Joint Pub 1-02)

naval special warfare forces. Those active and reserve component Navy forces designated by the Secretary of Defense that are specifically organized, trained, and equipped to conduct and support special operations. Also called NSW forces or NAVSOF. (Joint Pub 1-02)

naval special warfare group. A permanent Navy echelon III major command to which most naval special warfare forces are assigned for some operational and all administrative purposes. The group consists of a group headquarters with command and control, communications, and support staff, sea-air-land teams, and sea-air-land delivery vehicle teams. The group is the source of all deployed naval special warfare forces and administratively supports the naval special warfare units assigned to the theater combatant commanders. The group staff provides general operational direction and coordinates the activities of its subordinate units. A naval special warfare group is capable of task-organizing to meet a wide variety of requirements. Also called NSWG. (Approved for inclusion in the next edition of Joint Pub 1-02)

naval special warfare task element. A provisional subordinate element of a naval special warfare task unit, employed to extend the command and control and support capabilities of its parent task unit. Also called NSWTE. (Approved for inclusion in the next edition of Joint Pub 1-02)

naval special warfare task group. A provisional naval special warfare organization that plans, conducts, and supports special operations in support of fleet commanders and joint force special operations component commanders. Also called NSWTG. (This term and definition will replace the term and definition for "naval special warfare task group/unit" in Joint Pub 1-02.)

naval special warfare task unit. A provisional subordinate unit of a naval special warfare task group. Also called NSWTU. (This term and definition will replace the term and definition for "naval special warfare task group/unit" in Joint Pub 1-02.)

naval special warfare unit. A permanent Navy organization forward based to control and support attached naval special warfare forces. Also called NSWU. (Approved for inclusion in the next edition of Joint Pub 1-02)

Navy special operations component. The Navy component of a joint force special operations component. Also called NAVSOC. (Approved for inclusion in the next edition of Joint Pub 1-02)

on-call resupply. A resupply mission planned before insertion of a special operations team into the operations area but not executed until requested by the operating team. See also automatic resupply and emergency resupply. (Approved for inclusion in the next edition of Joint Pub 1-02)

operational control. Transferable command authority which may be exercised by commanders at any echelon at or below the level of combatant command. Operational control is inherent in Combatant Command (command authority) and is the authority to perform those functions of command over subordinate forces involving organizing and employing commands and forces, assigning tasks, designating objectives, and giving authoritative direction necessary to accomplish the mission. Operational control includes authoritative direction over all aspects of military operations and joint training necessary to accomplish missions assigned to the command. Operational control should be exercised through the commanders of subordinate organizations; normally this authority is exercised through the Service component commanders. Operational control normally provides full authority to organize commands and forces and to employ those forces as the commander in operational control considers necessary to accomplish assigned missions. Operational control does not, in and of itself, include authoritative direction for logistics or matters of administration, discipline, internal organization, or unit training. Also called OPCON. (Joint Pub 1-02)

operational environment. A composite of the conditions, circumstances, and influences that affect the employment of military forces and bear on the decisions of the unit commander. Some examples are: a. permissive environment--operational environment in which host country military and law enforcement agencies have control and the intent and capability to assist operations that a unit intends to conduct. b. uncertain environment--operational environment in which host government forces, whether opposed to or receptive to operations that a unit intends to conduct, do not have totally effective control of the territory and population in the intended area of operations. c. hostile environment--operational environment in which hostile forces have control and the intent and capability to effectively oppose or react to the operations a unit intends to conduct. (Approved for inclusion in the next edition of Joint Pub 1-02)

operational level of war. The level of war at which campaigns and major operations are planned, conducted, and sustained to accomplish strategic objectives within theaters or areas of operations. Activities at this level link tactics and strategy by establishing operational objectives needed to accomplish the strategic objectives, sequencing events to achieve the operational objectives, initiating actions, and applying resources to bring about and sustain these events. These activities imply a broader dimension of time or space than do tactics; they ensure the logistic and administrative support of tactical forces, and provide the means by which tactical successes are exploited to achieve strategic objectives. See also strategic level of war; tactical level of war. (Joint Pub 1-02)

operations security. A process of identifying critical information and subsequently analyzing friendly actions attendant to military operations and other activities to:

- a. Identify those actions that can be observed by adversary intelligence systems.
- b. Determine indicators hostile intelligence systems might obtain that could be interpreted or pieced together to derive critical information in time to be useful to adversaries.
- c. Select and execute measures that eliminate or reduce to an acceptable level the vulnerabilities of friendly actions to adversary exploitation.

Also called OPSEC. (Joint Pub 1-02)

overt operation. An operation conducted openly, without concealment. See also clandestine operation and covert operation. (Approved for inclusion in the next edition of Joint Pub 1-02)

paramilitary forces. Forces or groups which are distinct from the regular armed forces of any country, but resembling them in organization, equipment, training, or mission. (Joint Pub 1-02)

pararescue team. Specially trained personnel qualified to penetrate to the site of an incident by land or parachute, render medical aid, accomplish survival methods, and rescue survivors. (Joint Pub 1-02)

perishable target. A force or activity at a specific location whose value as a target can decrease substantially during a specified time. A significant decrease in value occurs when the target moves or the operational circumstances change to the extent that the target is no longer lucrative. (Approved for inclusion in the next edition of Joint Pub 1-02)

planning order. 1. An order issued by the Chairman of the Joint Chiefs of Staff to initiate execution planning. The planning order will normally follow a commander's estimate and a planning order will normally take the place of the CJCS alert order. NCA approval of a selected course of action is not required before issuing a CJCS planning order. 2. A planning directive that provides essential planning guidance and directs the initiation of execution planning before the directing authority approves a military course of action. (This term and its definition are provided for information and are proposed for inclusion in the next edition of Joint Pub 1-02 by Joint Pub 5-0.)

psychological operations. Planned operations to convey selected information and indicators to foreign audiences to influence their emotions, motives, objective reasoning, and ultimately the behavior of foreign governments, organizations, groups, and individuals. The purpose of psychological operations is to induce or reinforce foreign attitudes and behavior favorable to the originator's objectives. Also called PSYOP. (Joint Pub 1-02)

rangers. Rapidly deployable airborne light infantry organized and trained to conduct highly complex joint direct action operations in coordination with or in support of other special operations units of all Services. Rangers can also execute direct action operations in support of conventional nonspecial operations missions conducted by a combatant commander and can operate as conventional light infantry when properly augmented with other elements of combined arms. (Joint Pub 1-02)

sabotage. An act or acts with intent to injure, interfere with, or obstruct the national defense of a country by willfully injuring or destroying, or attempting to injure or destroy, any national defense or war material, premises, or utilities, to include human and natural resources. (Joint Pub 1-02)

sea-air-land team. A naval force specially organized, trained, and equipped to conduct special operations in maritime, littoral, and riverine environments. Also called SEAL team. (Approved for inclusion in the next edition of Joint Pub 1-02)

search and rescue. The use of aircraft, surface craft, submarines, specialized rescue teams and equipment to search for and rescue personnel in distress on land or at sea. Also called SAR. (Joint Pub 1-02)

security assistance. Groups of programs authorized by the Foreign Assistance Act of 1961, as amended, and the Arms Export Control Act of 1976, as amended, or other related statutes by which the United States provides defense articles, military training, and other defense-related services, by grant, loan, credit, or cash sales in furtherance of national policies and objectives. (Joint Pub 1-02)

special access program. A sensitive program, approved in writing by the head of an agency with original TOP SECRET classification authority, which imposes need-to-know and access controls beyond those normally provided for access to CONFIDENTIAL, SECRET, or TOP SECRET information. The level of controls is based on the criticality of the program and the assessed hostile intelligence threat. The program may be an acquisition program, an intelligence program, or an operations and support program. Also called a SAP. (Approved for inclusion in the next edition of Joint Pub 1-02)

special activities. Activities conducted in support of national foreign policy objectives which are planned and executed so that the role of the US Government is not apparent or acknowledged publicly. They are also functions in support of such activities but are not intended to influence United States political processes, public opinion, policies, or media and do not include diplomatic activities or the collection and production of intelligence or related support functions. (Joint Pub 1-02)

special air operation. An air operation conducted in support of special operations and other clandestine, covert, and psychological activities. (Approved for inclusion in the next edition of Joint Pub 1-02)

special boat squadron. A permanent Navy echelon III major command to which two or more special boat units are assigned for some operational and all administrative purposes. The squadron is tasked with the training and deployment of these special boat units and may augment naval special warfare task groups and task units. Also called SBR. (Approved for inclusion in the next edition of Joint Pub 1-02)

special boat unit. Those US Navy forces organized, trained, and equipped to conduct or support naval special warfare, riverine warfare, coastal patrol and interdiction, and joint special operations with patrol boats or other combatant craft designed primarily for special operations support. Also called SBU. (Joint Pub 1-02)



special forces. US Army forces organized, trained, and equipped specifically to conduct special operations. Special forces have five primary missions: unconventional warfare, foreign internal defense, direct action, special reconnaissance, and counterterrorism. Counterterrorism is a special mission for specially organized, trained, and equipped special forces units designated in theater contingency plans. Also called SF. (Joint Pub 1-02)

special forces group. A combat arms organization capable of planning, conducting, and supporting special operations activities in all operational environments in peace, conflict, and war. It consists of a group headquarters and headquarters company, a support company, and special forces battalions. The group can operate as a single unit, but normally the battalions plan and conduct operations from widely separated locations. The group provides general operational direction and synchronizes the activities of subordinate battalions. Although principally structured for unconventional warfare, special forces group units are capable of task-organizing to meet specific requirements. Also called SFG. (Joint Pub 1-02)

special forces operations base. A command, control, and support base established and operated by a special forces group or battalion from organic and attached resources. The base commander and his staff coordinate and synchronize the activities of subordinate and forward-deployed forces. A special forces operations base is normally established for an extended period of time to support a series of operations. Also called SFOB. (Joint Pub 1-02)

special mission unit. A generic term to represent a group of operations and support personnel from designated organizations that is task-organized to perform highly classified activities. Also called SMU. (Approved for inclusion in the next edition of Joint Pub 1-02)

special operations. Operations conducted by specially organized, trained, and equipped military and paramilitary forces to achieve military, political, economic, or psychological objectives by unconventional military means in hostile, denied, or politically sensitive areas. These operations are conducted during peacetime competition, conflict, and war, independently or in coordination with operations of conventional, nonspecial-operations forces. Political-military considerations frequently shape special operations, requiring clandestine, covert, or low visibility techniques and oversight at the national level. Special operations differ from conventional operations in degree of

physical and political risk, operational techniques, mode of employment, independence from friendly support, and dependence on detailed operational intelligence and indigenous assets. Also called SO. (Joint Pub 1-02)

special operations combat control team. A team of Air Force personnel organized, trained, and equipped to conduct and support special operations. Under clandestine, covert, or low-visibility conditions, these teams establish and control air assault zones; assist aircraft by verbal control, positioning, and operating navigation aids; conduct limited offensive direct action and special reconnaissance operations; and assist in the insertion and extraction of special operations forces. Also called SOCCT. (Approved for inclusion in the next edition of Joint Pub 1-02)

special operations command. A subordinate unified or other joint command established by a joint force commander to plan, coordinate, conduct, and support joint special operations within the joint force commander's assigned area of operations. Also called SOC. (Approved for inclusion in the next edition of Joint Pub 1-02)

special operations forces. Those active and reserve component forces of the military Services designated by the Secretary of Defense and specifically organized, trained, and equipped to conduct and support special operations. Also called SOF. (Approved for inclusion in the next edition of Joint Pub 1-02)

special operations naval mobile environment team. A team of Navy personnel organized, trained, and equipped to support naval special warfare forces by providing weather, oceanographic, mapping, charting, and geodesy support. Also called SONMET. (Approved for inclusion in the next edition of Joint Pub 1-02)

special operations peculiar. Equipment, materials, supplies, and services required for special operations mission support for which there is no broad conventional force requirement. It often includes nondevelopmental or special category items incorporating evolving technology but may include stocks of obsolete weapons and equipment designed to support indigenous personnel who do not possess sophisticated operational capabilities. (Joint Pub 1-02)

special operations weather team/tactical element. A task-organized team of Air Force personnel organized, trained, and equipped to collect critical weather observations from data-sparse areas. These teams are trained

to operate independently in permissive or uncertain environments, or as augmentation to other special operations elements in hostile environments, in direct support of special operations. Also called SOWT/TE. (Joint Pub 1-02)

special reconnaissance. Reconnaissance and surveillance actions conducted by special operations forces to obtain or verify, by visual observation or other collection methods, information concerning the capabilities, intentions, and activities of an actual or potential enemy or to secure data concerning the meteorological, hydrographic, or geographic characteristics of a particular area. It includes target acquisition, area assessment, and post-strike reconnaissance. (Joint Pub 1-02)

special tactics team. An Air Force team composed primarily of special operations combat control and pararescue personnel. The team supports joint special operations by selecting, surveying, and establishing assault zones; providing assault zone terminal guidance and air traffic control; conducting direct action missions; providing medical care and evacuation; and coordinating, planning, and conducting air, ground, and naval fire support operations. (Approved for inclusion in the next edition of Joint Pub 1-02)

strategic level of war. The level of war at which a nation or group of nations determines national or alliance security objectives and develops and uses national resources to accomplish those objectives. Activities at this level establish national and alliance military objectives; sequence initiatives; define limits and assess risks for the use of military and other instruments of power; develop global or theater war plans to achieve those objectives; and provide armed forces and other capabilities in accordance with the strategic plan. See also operational level of war; tactical level of war. (Joint Pub 1-02)

subversion. Action designed to undermine the military, economic, psychological, political strength or morale of a regime. See also unconventional warfare. (Joint Pub 1-02)

supporting agency.\* In special operations, a military unit or nonmilitary organization tasked to provide operational support for a particular special operations mission as requested by the mission planning agent. There may be more than one supporting agency for a single special operations mission. See also mission planning agent.

tactical control. The detailed and, usually, local direction and control of movements or maneuvers necessary to accomplish missions or tasks assigned. Also called TACON. (Joint Pub 1-02)

tactical level of war. The level of war at which battles and engagements are planned and executed to accomplish military objectives assigned to tactical units or task forces. Activities at this level focus on the ordered arrangement and maneuver of combat elements in relation to each other and to the enemy to achieve combat objectives. See also operational level of war; strategic level of war. (Joint Pub 1-02)

task-organizing. The act of designing an operating force, support staff, or logistics package of specific size and composition to meet a unique task or mission. Characteristics to examine when task-organizing the force include, but are not limited to: training, experience, equipment, sustainability, operating environment, enemy threat, and mobility. (Joint Pub 1-02)

terrorism. The unlawful use or threatened use of force or violence against individuals or property to coerce or intimidate governments or societies, often to achieve political, religious, or ideological objectives. See also antiterrorism, combatting terrorism, and counterterrorism. (Joint Pub 1-02)

unconventional warfare. A broad spectrum of military and paramilitary operations, normally of long duration, predominantly conducted by indigenous or surrogate forces who are organized, trained, equipped, supported, and directed in varying degrees by an external source. It includes guerrilla warfare and other direct offensive, low visibility, covert, or clandestine operations, as well as the indirect activities of subversion, sabotage, intelligence activities, and evasion and escape. Also called UW. (Joint Pub 1-02)

warning order. 1. A crisis action planning directive issued by the Chairman of the Joint Chiefs of Staff that initiates the development and evaluation of courses of action by a supported commander and requests that a commander's estimate be submitted. 2. A planning directive that describes the situation, allocates forces and resources, establishes command relationships, provides other initial planning guidance, and initiates subordinate unit mission planning. (This term and its definition are provided for information and are proposed for inclusion in the next edition of Joint Pub 1-02 by Joint Pub 5-0.)

---

\* This term and definition are applicable only in the context of this pub and cannot be referenced outside of this publication.

(INTENTIONALLY BLANK)